

PRODUCT INFORMATION PACKET

marathon[®]
Motors

Model No: 284TTFPA14055
Catalog No: Y1613
25,1800,TEFC,284T,3/60/230/460
Fire Pump

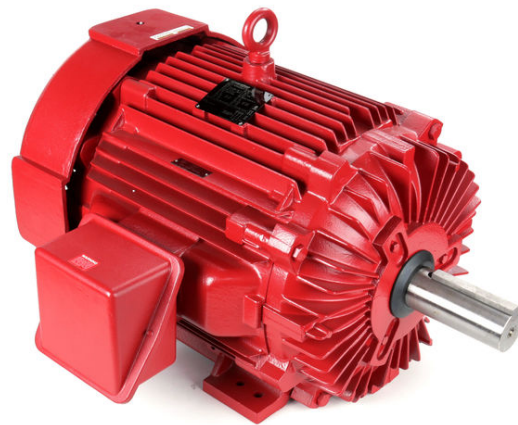

Regal and Marathon are trademarks of Regal Beloit Corporation or one of its affiliated companies.
©2018 Regal Beloit Corporation, All Rights Reserved. MC017097E

REGAL[®]



Nameplate Specifications

Output HP	25 Hp	Output KW	18.7 kW
Frequency	60 Hz	Voltage	230/460 V
Current	61.0/30.5 A	Speed	1775 rpm
Service Factor	1.15	Phase	3
Efficiency	92.4 %	Duty	Continuous
Insulation Class	F	Design Code	B
KVA Code	G	Frame	284T
Enclosure	Totally Enclosed Fan Cooled	Overload Protector	No
Ambient Temperature	40 °C	Drive End Bearing Size	6311
Opp Drive End Bearing Size	6210	UL	Recognized
CSA	Y	CE	Y
IP Code	43		

Technical Specifications

Electrical Type	Squirrel Cage Induction Run	Starting Method	Part Wdg Start Low Volt Only & Wye Start Delta Run
Poles	4	Rotation	Reversible
Mounting	Rigid base	Motor Orientation	HORIZONTAL
Drive End Bearing	BALL	Opp Drive End Bearing	BALL
Frame Material	Cast Iron	Shaft Type	T
Overall Length	26.39 in	Frame Length	12.76 in
Shaft Diameter	1.875 in	Shaft Extension	4.87 in
Assembly/Box Mounting	F1/F2 CAPABLE		
Outline Drawing	B-SS311037-1275	Connection Diagram	A-EE7358

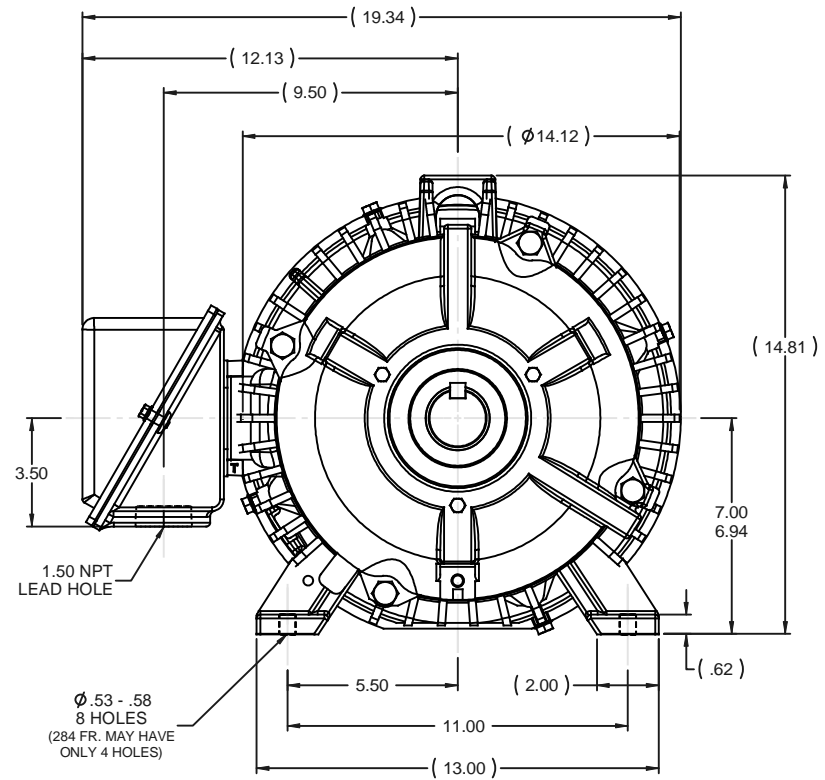
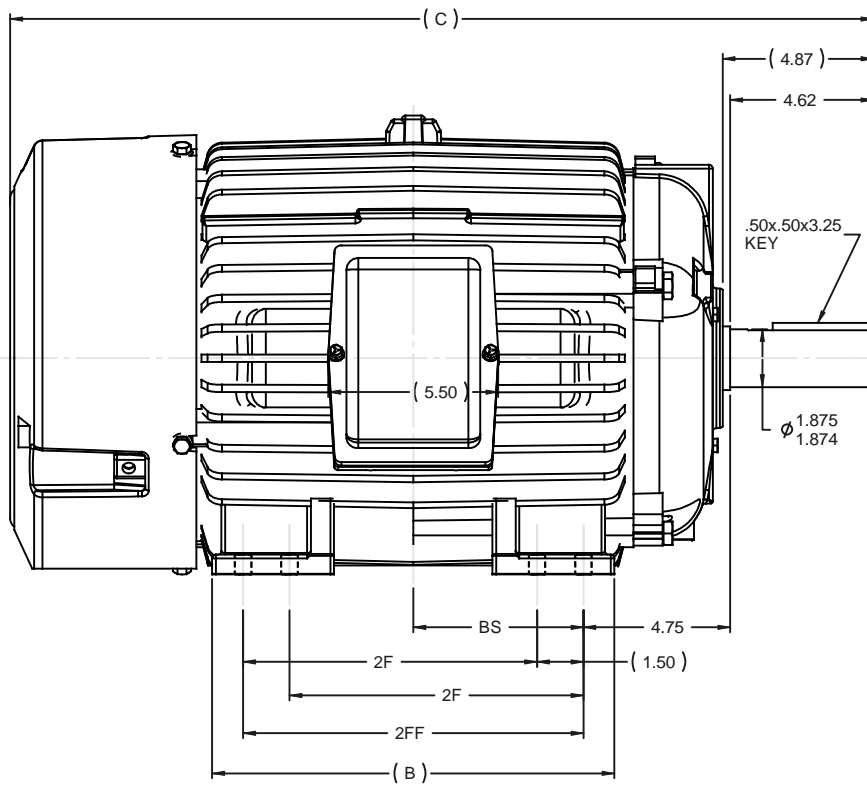

- NOTES:
 1- CONDUIT BOX CAN BE ROTATED IN 90° STEPS.
 2- CONDUIT BOX CAN BE MOUNTED ON OPPOSITE SIDE BY REMOVING BRACKETS AND TURNING FRAME 180°
 3- NAMEPLATE TO BE READ FROM CONDUIT BOX SIDE OF MOTOR.

DASH	FRAME	B	C	2F	2FF	BS
1275	284T	11.50	26.39	9.50		4.75
1425	286T	13.00	27.89	9.50	11.00	5.50

NO	REVISION	BY & DATE	CHK	ANG	FINISH
4	REVISED MOUNTING HOLE QUANTITY CN 40694	DRS 10-25-2008 ML	x	±.1	
3	REDRAWN IN AUTOCAD	TAT 05-19-2005 ML	xx	±.03	
2	REMOVED DUAL DRILLING FROM FEET CN 29200-991	NJS 10-26-2000	xxx	±.005	
1	NEW DRAWING	DRS 07-10-2000	xxx	±.0005	

TOLERANCES UNLESS SPECIFIED			DRAWN	DRS 07-06-2000
DEC	INCHES		CHK	ML 07-10-2000
		TITLE		SCALE 1:4
		280T FR. - STD - 11.00 LAM - CAST C'BOX		REF
		MATERIAL		FMF
		FINISH		PREV SS200126
THIS DRAWING IN DESIGN AND DETAIL IS OUR PROPERTY AND MUST NOT BE USED EXCEPT IN CONNECTION WITH OUR WORK. ALL RIGHTS OF DESIGN AND INVENTION ARE RESERVED. THIS IS AN ELECTRONICALLY GENERATED DOCUMENT - DO NOT SCALE THIS PRINT		RFP	CAD FILE SS311037	SIZE
		DIST	LB	DRAWING NO
				SS311037
				REV
				4

HIGH VOLTAGE

WYE START

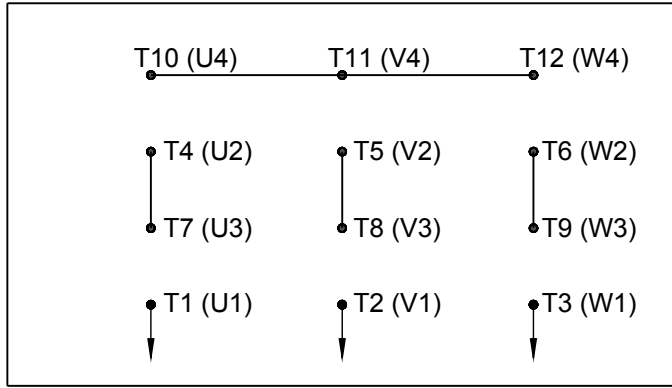

DELTA RUN

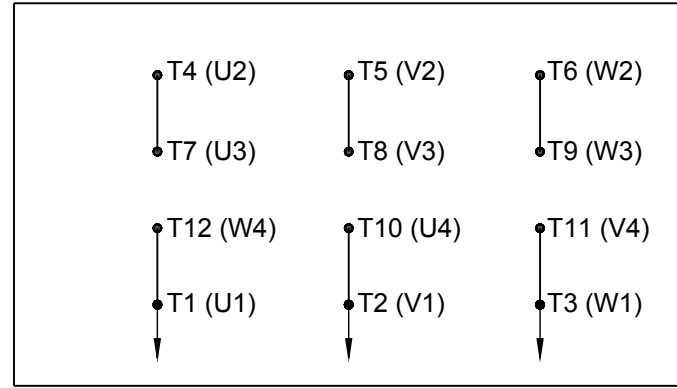

WYE START

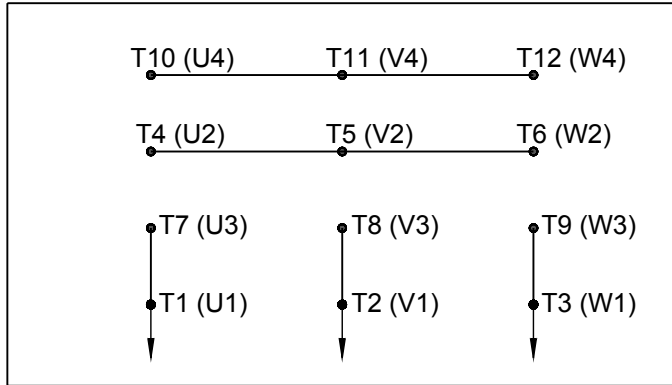

LOW VOLTAGE

DELTA RUN

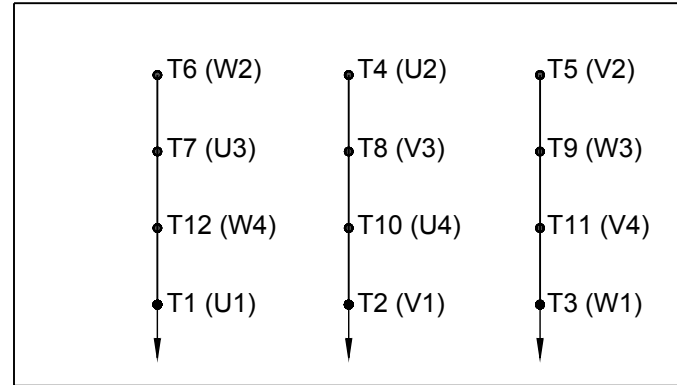

4/2 CKTY \triangle

DRAWING REVISION D	REVISION BY JWO	DATE 01-26-2016
ECO ECO-0092547	APPROVED BY TB	DATE 01-26-2016

ECO DESCRIPTION
ADDED IEC MARKINGS

COPYRIGHT REGAL BELOIT AMERICA, INC. ALL RIGHTS RESERVED. PROPRIETARY AND CONFIDENTIAL INFORMATION - THIS DOCUMENT IS THE PROPERTY OF REGAL BELOIT AMERICA, INC. ("OWNER") AND CONTAINS OWNER'S PROPRIETARY INFORMATION. ANY PERSON, CORPORATION OR OTHER FIRM RECEIVING IT IS DEEMED, BY RECEIVING IT, TO AGREE THAT IT, AND/OR ANY PART OF IT, SHALL NOT BE DISCLOSED TO ANY PERSON, CORPORATION OR OTHER ENTITY, DUPLICATED, AND/OR USED, EXCEPT AS EXPRESSLY APPROVED IN WRITING IN ADVANCE BY OWNER. THIS DOCUMENT SHALL BE RETURNED TO OWNER UPON REQUEST. IT MAY BE SUBJECT TO CERTAIN RESTRICTIONS UNDER APPLICABLE EXPORT CONTROL LAWS AND REGULATIONS.

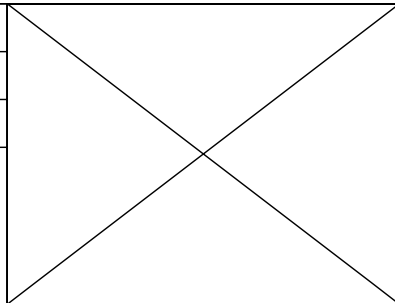

DRAWN BY BLR		Regal Beloit America, Inc.
DATE 03-09-1998		
APPROVED BY GK	DESCRIPTION CONN DIAGRAM-EXTERNAL	
DATE 03-23-1998	12 LEAD - DUAL VOLT. - WYE START - DELTA RUN	
REFERENCE	MATERIAL	PROCESS/FINISH
THIRD ANGLE PROJECTION	SIZE A	DRAWING NUMBER EE7358

SHEET 1 OF 1	
-----------------	--



P.O. BOX 8003
WAUSAU, WI 54401-8003
PH. 715-675-3311

DATA VOLTS: 460

CERTIFICATION DATA SHEET

CUSTOMER P.O. #:
 ORDER #: A-EE7358
 REFERENCE MODEL #: 284TTPA14055
 CONN. DIAGRAM: B-SS311037-1275
 CAT #: N/A
 WINDING: K2564251 NONE 5 CUSTOMER PART #:
 MOUNTING: F1/F2 CAPABLE
 SPEED:
 TYPICAL MOTOR PERFORMANCE DATA

HP	KW	SYNC RPM	FL RPM	FRAME	ENCLOSURE	TYPE	KVA CODE	DESIGN
25	18.7	1800	1775	284T	TEFC	TEP	G	B

PH	HZ	VOLTS	AMPS	START TYPE	DUTY	INSL	S.F.	AMB	ELEV.
3	60/50	230/460#190/380	61/30.5&80/30	WS(LV ONLY) & YDRU	CONT	F	1.15	40	3300
	F.L. EFF	92.4	3/4 LD EFF	92.4	1/2 LD EFF	92.4	GTD EFF	ELECT. TYPE	
	F.L. PF	83.0	3/4 LD PF	78.5	1/2 LD PF	69.0	91.0	SQ CAGE IND RUN	
F.L. TORQUE	LR AMPS @ 460 V	L.R. TORQUE	B.D. TORQUE	F.L. RISE (°C)					
74.0 LB-FT	178	145 LB-FT	196%	190 LB-FT	257%	75			
@ 3 FT.	POWER	ROTOR WK ²	MAX. LOAD WK ²	SAFE STALL TIME	START/SHOUR	MOTOR WGT			
72 DBA	81 DBA	3.2 LB-FT ²	0 LB-FT ²	20 SEC.	0	500 LB.			

*** SUPPLEMENTAL INFORMATION ***

DE BRACKET TYPE	ODE BRACKET TYPE	MOUNT TYPE	MOTOR ORIENTATION	SEVERE DUTY	HAZARDOUS LOCATION	DRIP COVER	SCREENS	PAINT
STANDARD	STANDARD	RIGID	HORIZONTAL	NO	NONE	NO	NONE	RED (ENAMEL)
BEARINGS	GREASE	SHAFT TYPE	SPECIAL DE	SPECIAL ODE	SHAFT	MATERIAL	FRAME MATERIAL	
DE BALL 6311	POLYREX EM	T	NONE	NONE	1045 HOT ROLLED (C-204)		CAST IRON	

THERMOSTATS	PROTECTORS	WDG RTD's	BRG RTD's	THERMISTORS	CONTROL	SPACE HEATERS
NONE	NOT	NONE	NONE	NONE	FALSE	NA
R1 (ohms/ph)	R2 (ohms/ph)	X1 (ohms/ph)	X2 (ohms/ph)	Xm (ohms/ph)	VIBRATION (in/sec)	FLOAT
0.234	1.379	0.821	1.231	21.934	0.150	ODE

* N		INVERTER TORQUE: NONE	
O	INV. HP SPEED RANGE: NONE		
T	ENCODER: NONE		
E	BRAKE: NONE		
S	FT-LB: NONE		
	VOLTAGE: NONE		
	HZ: NONE		

PREPARED BY: FAREEDA DUDEKULA
 DATE: 9/17/2018
 FORM: 3531 REV 4 2/27/06
 UL: V-INS, CONST UL REC

Data Sheet

Date: 9/17/2018

Customer: _____
 Attention: _____

Submitted by: FAREEDA DUDEKULA



284TTFPA14055

Submital

Data @ 460 V

Load	Motor Load Data									
	0%	25%	50%	75%	100%	115%	125%	LR		
Current (Amps)	12.0	14.0	18.2	24.0	30.5	35.0	37.5	178		
Torque (ft-lb)	0.00	18.3	36.7	55.4	74.0	85.5	93.0	145		
RPM	1800	1795	1785	1780	1775	1,770	1765	0		
Efficiency (%)		88.5	92.4	92.4	92.4	92.4	91.7			
P.F. (%)	5.5	47.0	69.0	78.5	83.0	84.0	84.5	42.0		

	Motor Speed Data					Information Block																		
	LR	Pull-Up	BD	Rated	Idle	HP	Frame	Enclosure	Construction	Voltage	Frequency	Design	LR Code letter	Service Factor	Temp Rise @ FL	Duty	Ambient	Elevation	Motor/Shaft Wk ²	Sound Pressure @ 1M	VFD Rating	Outline Dwg	Conn. Diag	Additional Specifications:
Speed (RPM)	0	900	1625	1775	1800	25.0	284182TFC080	TEFC	TFF	230/460#190/380	60	B	G	1.15	75	CONT	40	1,000	3.2	72	NONE	B-SS311037-1275	A-EE7358	
Current (Amps)	178	165	105	30.5	12.0																			
Torque (ft-lb)	145	125	190	74.0	0.00																			

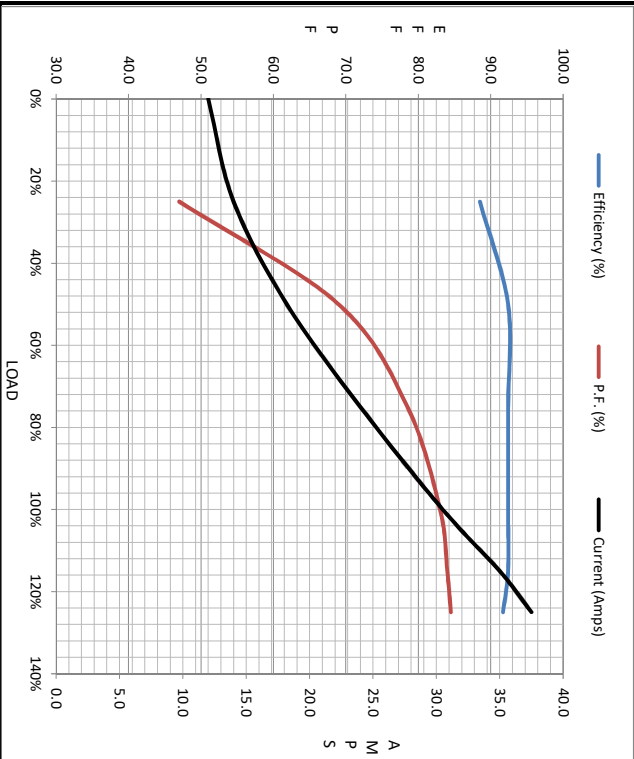

	R1	R2	X1	X2	Xm
EQUIV CKT (OHMS / PHASE)	0.2340	1.3790	0.8210	1.2310	21.9340

