

PRODUCT INFORMATION PACKET

Model No: 056C11G5307
Catalog No: G652
1/3,1200,EPFC,56,1/60/115/208-230
Explosion Proof



Regal and Marathon are trademarks of Regal Beloit Corporation or one of its affiliated companies.
©2018 Regal Beloit Corporation, All Rights Reserved. MC017097E



Nameplate Specifications

Output HP	0.33 Hp	Output KW	0.25 kW
Frequency	60 Hz	Voltage	115/208-230 V
Current	7.8/3.6-3.9 A	Speed	1140 rpm
Service Factor	1	Phase	1
Efficiency	52.5 %	Duty	Continous
Insulation Class	B	Design Code	NO DESIGN CODE
KVA Code	N	Frame	56
Enclosure	Explosion Proof Fan cooled	Overload Protector	Automatic
Ambient Temperature	40 °C	Drive End Bearing Size	6203
Opp Drive End Bearing Size	6203	UL	Recognized
CSA	N	CE	N
IP Code	54		

Technical Specifications

Electrical Type	Capacitor Start Induction Run	Starting Method	Across The Line
Poles	6	Rotation	Selective Counterclockwise
Mounting	Rigid base	Motor Orientation	Horizontal
Drive End Bearing	Ball	Opp Drive End Bearing	Ball
Frame Material	Rolled Steel	Shaft Type	T
Overall Length	13.94 in	Frame Length	6.81 in
Shaft Diameter	0.625 in	Shaft Extension	2 in
Assembly/Box Mounting	F1 Only		
Outline Drawing	B-104189-681	Connection Diagram	102005-84

This is an uncontrolled document once printed or downloaded and is subject to change without notice. Date Created: 06/29/2018

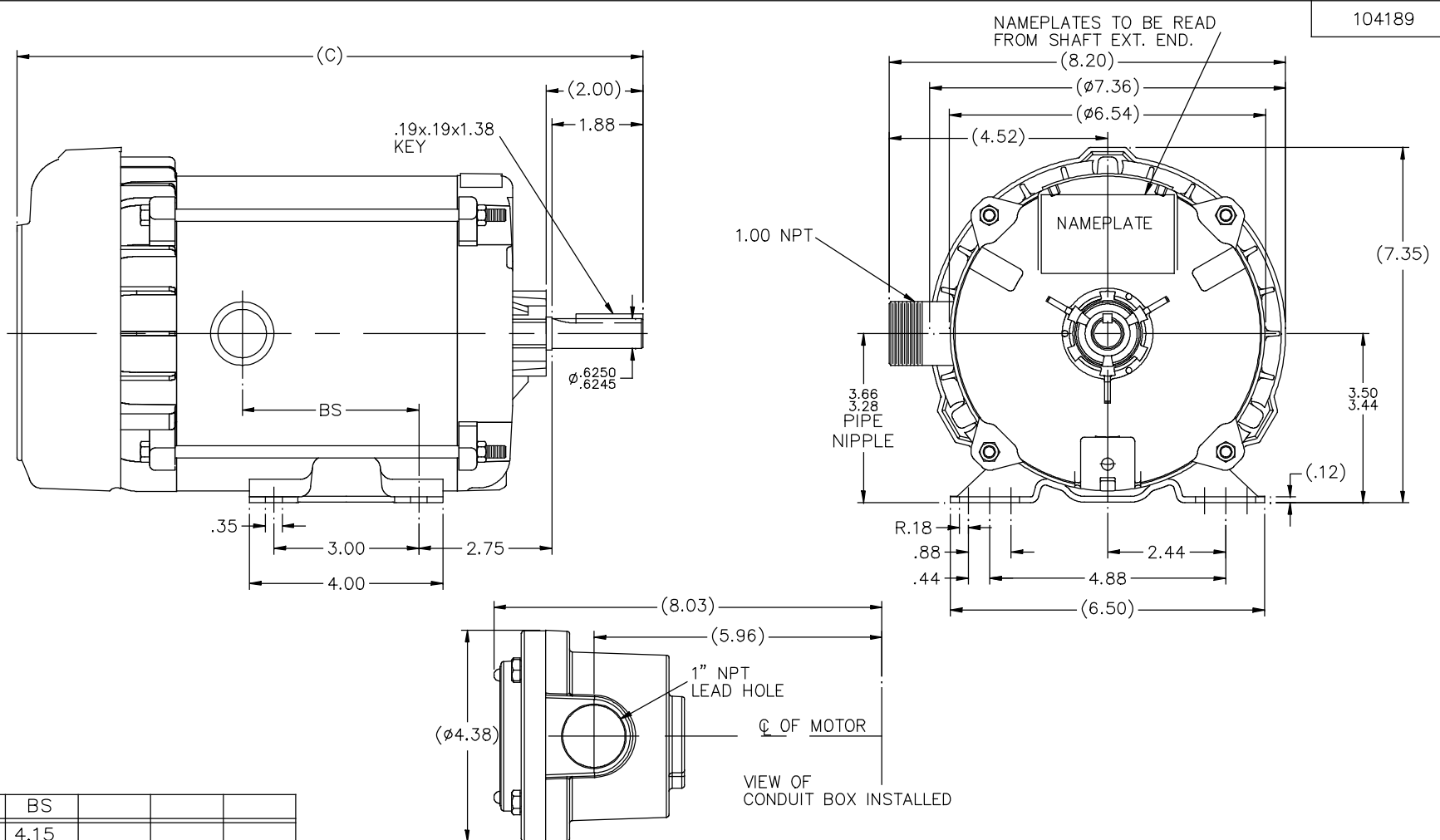

104189

DASH	(C)	BS			
631	13.44	4.15			
681	13.94	4.65			
731	14.44	5.15			
781	14.94	5.65			
831	15.44	6.15			
881	15.94	6.65			
931	16.44	7.15			
981	16.94	7.65			

				TOLERANCES UNLESS SPECIFIED		REGAL™ Regal Beloit America, Inc.		DRAWN MH 11-20-1996	
				DEC.	INCHES			CHK	ML 12-02-1996
4	COND. BOX INSTALLED VIEW UPDATED PER ECR-0044571	UD	10/15/13	ST	.X	±.1		APPD	GK 12-02-1996
3	REVISED C'BOX PER CN40784A	JJB	02/23/2007	ML	.XX	±.03	TITLE OUTLINE	SCALE	1=2
2	ADDED CONDUIT BOX VIEW CN 26686	MRB	03-22-1998		.XXX	±.005	56 FR. - EXP. PR. - TEFC - 1Ø & 3Ø	REF	
1	NEW DRAWING CN 23099	MH	12-02-1996		.XXXX	±.0005	MAT'L	FMF	
NO.	REVISION	BY & DATE		CHK	ANG	±7'30"	FINISH	PREV	
THIS DRAWING IN DESIGN AND DETAIL IS OUR PROPERTY AND MUST NOT BE USED EXCEPT IN CONNECTION WITH OUR WORK. ALL RIGHTS OF DESIGN AND INVENTION ARE RESERVED. THIS IS AN ELECTRONICALLY GENERATED DOCUMENT - DO NOT SCALE THIS PRINT				RFP	CAD FILE 104189			SIZE	DRAWING NO. PAGE OF REV.
				DIST	WP			B	104189 4

102005-84

LOW VOLTAGE - C.C.W.

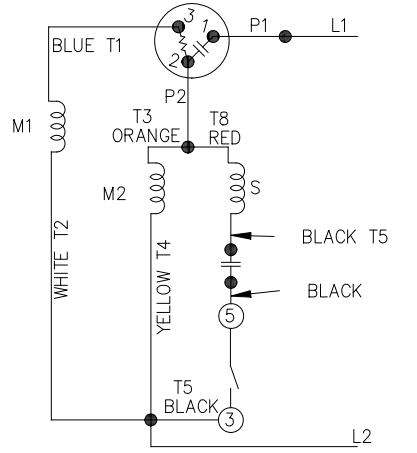

HIGH VOLTAGE - C.C.W.

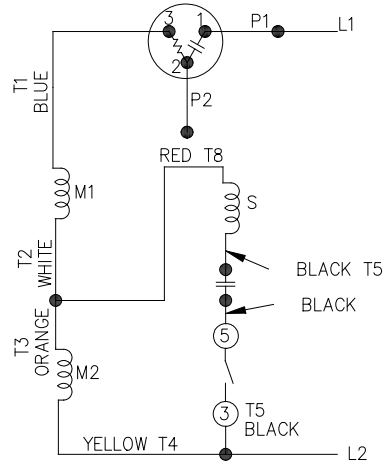

DUAL VOLTAGE
CAPACITOR START
OVERLOAD SELECT ROT.

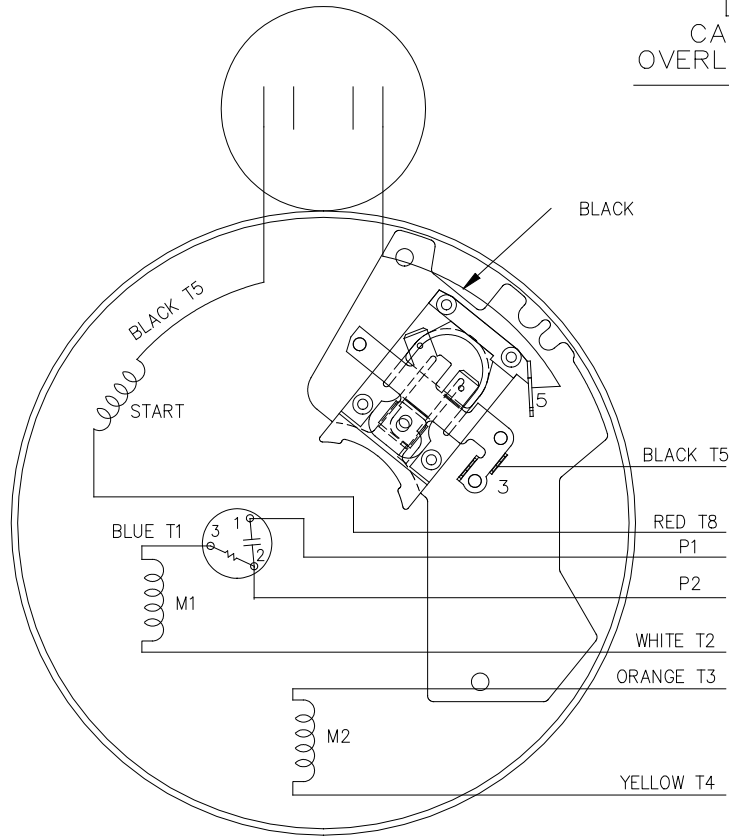

LOW VOLT. - C.C.W. ROT.

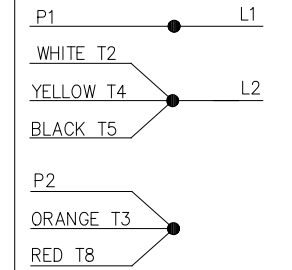

HIGH VOLT. - C.C.W. ROT.

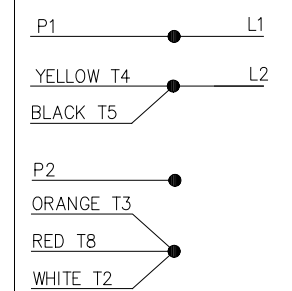

FOR C.W. ROTATION
EITHER VOLTAGE
INTERCHANGE RED(T8)
WITH BLACK(T5) LEAD

NO.	REVISION	BY & DATE	CHK	ANG	TOLERANCES UNLESS SPECIFIED		REGAL™ Regal Beloit America, Inc.	DRAWN PGK 07-16-1996	
					DEC.	INCHES			
5	UPDATED TEMPLETE	MVG 12/11/2017	PVR	.X	±.1			CHK MRB 07-18-1996	
4	REV'D CONNECTION TO MATCH ROTATION ISAAC 07-2021	JJB 09/05/2007	ML	.XX	±.02		TITLE CONNECTION DIAGRAM	APPD GK 07-18-1996	
3	ADDED T NO.'S MU16064	MH 08-09-1997		.XXX	±.005			SCALE 5=8	
2	REDRAWN ON CADD, NO CHANGES	PGK 07-18-1996		.XXXX	±.0005		MAT'L.	REF	
				ANG	±7'30"		FINISH	FMF	
			RFP			CAD FILE 102005_84		PREV	
THIS DRAWING IN DESIGN AND DETAIL IS OUR PROPERTY AND MUST NOT BE USED EXCEPT IN CONNECTION WITH OUR WORK ALL RIGHTS OF DESIGN AND INVENTION ARE RESERVED THIS IS AN ELECTRONICALLY GENERATED DOCUMENT - DO NOT SCALE THIS PRINT							SIZE A	DRAWING NO. 102005-84	PAGE OF 5
							DIST WP		REV. 5

CERTIFICATION DATA SHEET

Model#: 56C11G5307 F WINDING#: ZC605 R1 3
 CONN. DIAGRAM: 102005-84 ASSEMBLY: F1 ONLY
 OUTLINE: B-104189-681

TYPICAL MOTOR PERFORMANCE DATA

HP	KW	SYNC. RPM	F.L. RPM	FRAME	ENCLOSURE	KVA CODE	DESIGN
1/3	.25	1200	1140	56	EPFC	N	NO DESIGN CODE

PH	Hz	VOLTS	FL AMPS	START TYPE	DUTY	INSL	S.F	AMB°C	ELEVATION
1	60	115/208-230	7.8/3.6-3.9	ACROSS THE LINE	CONTINUOUS	B3	1.0	40	3300

FULL LOAD EFF: 52.5	3/4 LOAD EFF: 47.9	1/2 LOAD EFF: 39.4	GTD. EFF	ELEC. TYPE	NO LOAD AMPS
FULL LOAD PF: 53.8	3/4 LOAD PF: 44.6	1/2 LOAD PF: 36.8	0	CAP START IND RUN	7.3 / 3.7

F.L. TORQUE	LOCKED ROTOR AMPS	L.R. TORQUE	B.D. TORQUE	F.L. RISE°C
24 LB-FT	35.8 / 17.9	77.1 LB-FT 321	66.9 LB-FT 279	68

SOUND PRESSURE @ 3 FT.	SOUND POWER	ROTOR WK^2	MAX. WK^2	SAFE STALL TIME	STARTS /HOUR	APPROX. MOTOR WGT
0 dBA	10 dBA	0 LB-FT^2	0 LB-FT^2	10 SEC.	0	0 LBS.

*** SUPPLEMENTAL INFORMATION ***

DE BRACKET TYPE	ODE BRACKET TYPE	MOUNT TYPE	ORIENTATION	SEVERE DUTY	HAZARDOUS LOCATION	DRIP COVER	SCREENS	PAINT
STANDARD	STANDARD	RIGID	HORIZONTAL	FALSE	EXP PROOF CL I GR C&D CL II GR F&G T3B	FALSE	NONE	GRAY (POWDER)

BEARINGS		GREASE	SHAFT TYPE	SPECIAL DE	SPECIAL ODE	SHAFT MATERIAL	FRAME MATERIAL
DE	OPE						
BALL	BALL	POLYREX EM	T	NONE	NONE	1144 STRESSPROOF (C-223)	ROLLED STEEL
6203	6203						

THERMO-PROTECTORS				THERMISTORS	CONTROL	SPACE /n HEATERS
THERMOSTATS	PROTECTORS	WDG RTDs	BRG RTDs			
NONE	AUTOMATIC	NONE	NONE	NONE	FALSE	NONE VOLTS

If Inverter equals NONE, contact factory for further information

*
N
O
T
E
S
*

INVERTER TORQUE: NONE
INV. HP SPEED RANGE: NONE
ENCODER: NONE
NONE NONE
NONE NONE PPR
BRAKE: NONE NONE
NONE P/N NONE
NONE NONE
NONE FT-LB NONE V NONE Hz

