

PRODUCT INFORMATION PACKET

Model No: 056T11O5306
Catalog No: X523
1-1/2,1140,OPEN,56HZ,3/60/230/460
Condenser Fans



Regal and Marathon are trademarks of Regal Beloit Corporation or one of its affiliated companies.
©2018 Regal Beloit Corporation, All Rights Reserved. MC017097E





Nameplate Specifications

Output HP	1.50 Hp	Output KW	1.1 kW
Frequency	60 Hz	Voltage	208-230/460 V
Current	5.4-5.4/2.7 A	Speed	1140 rpm
Service Factor	1	Phase	3
Efficiency	78.5 %	Duty	Continuous
Insulation Class	H	Design Code	NO DESIGN CODE
KVA Code	J	Frame	56HZ
Enclosure	Open Air Over	Overload Protector	Auto Lock Rotor Only
Ambient Temperature	70 °C	Drive End Bearing Size	6203
Opp Drive End Bearing Size	6203	UL	Recognized
CSA	Y	CE	N
IP Code	10		

Technical Specifications

Electrical Type	Squirrel Cage Induction Run	Starting Method	Across The Line
Poles	6	Rotation	Reversible
Mounting	Rigid base	Motor Orientation	Horizontal
Drive End Bearing	Ball	Opp Drive End Bearing	Ball
Frame Material	Rolled Steel	Shaft Type	Single Special Extension
Overall Length	15.68 in	Frame Length	8.56 in
Shaft Diameter	0.625 in	Shaft Extension	5.06 in
Assembly/Box Mounting	F1 Only		
Outline Drawing	A-100166-856	Connection Diagram	A-102007-1

This is an uncontrolled document once printed or downloaded and is subject to change without notice. Date Created: 06/29/2018

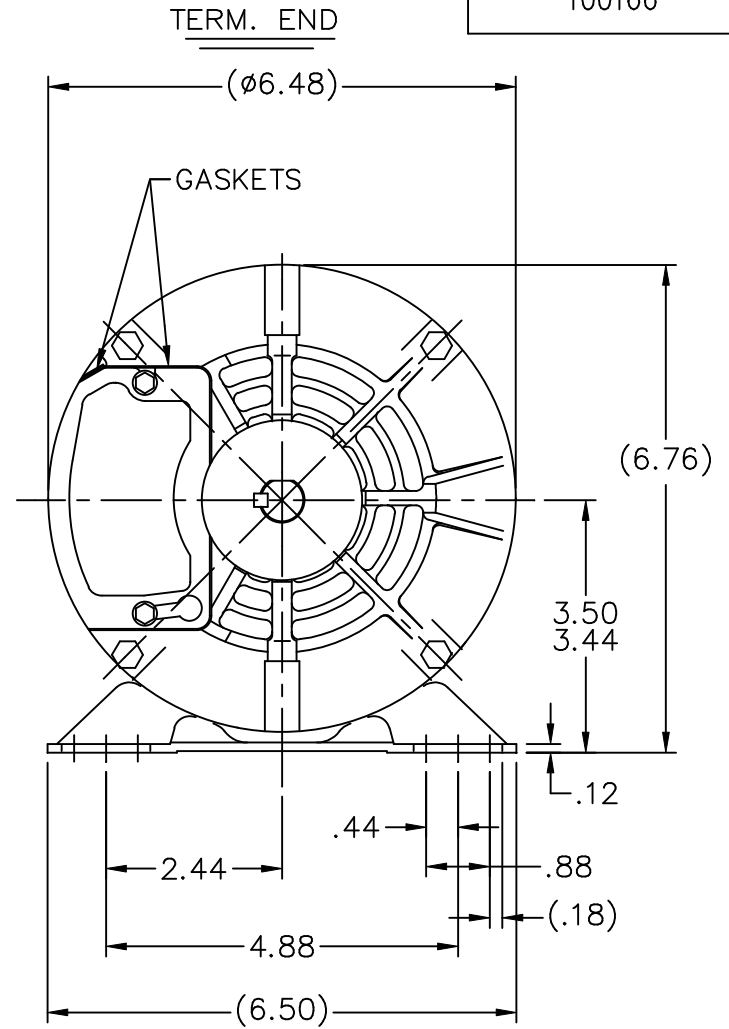
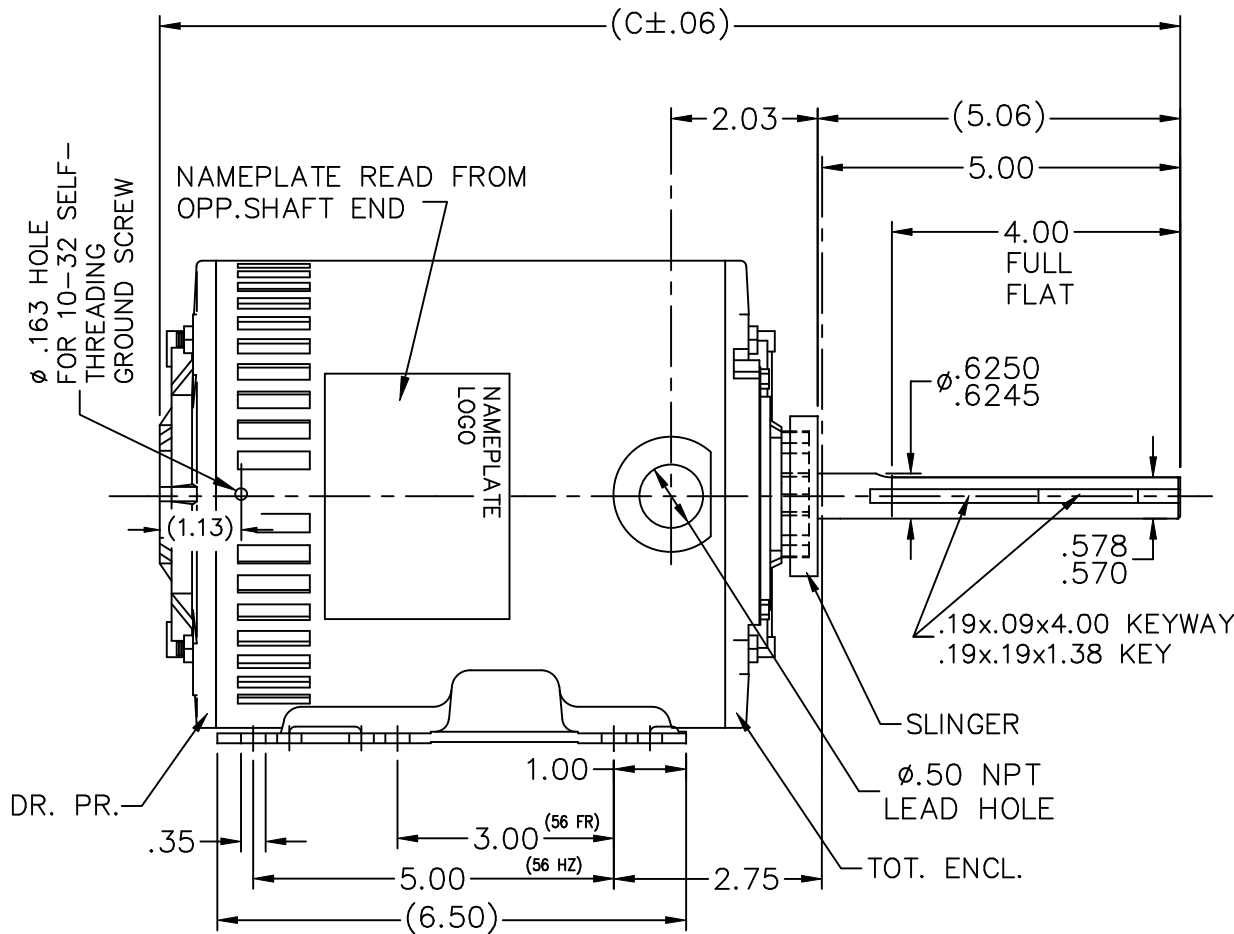

DASH	FR.	C	DASH	FR.	C
706	56-70	14.18	906	56-90	16.18
756	56-75	14.68	956	56-95	16.68
806	56-80	15.18			
856	56-85	15.68			

			TOLERANCES UNLESS SPECIFIED			DRAWN MJD 03-27-1998				
			DEC.	INCHES		CHK	ML	04-02-1998		
6	ADDED DASH VALUES	PBS 3/6/2007	NB	.X	±.1	APPD	GK	04-02-1998	SCALE	3=8
5	REVISED FLAT TO 3 PLACE DECIMAL TOLERANCE	TAT 03-14-2005	ML	.XX	±.03	TITLE OUTLINE				
4	REDRAWN IN AUTOCAD	TAT 08-03-2004	ML	.XXX	±.005	56 FR. CONDENSER MOTOR				
3	REDRAWN ON CADD	MJD 04-02-1998		.XXXX	±.0005	MAT'L.				
NO.	REVISION	BY & DATE	CHK	ANG	±7'30"	FINISH				
THIS DRAWING IN DESIGN AND DETAIL IS OUR PROPERTY AND MUST NOT BE USED EXCEPT IN CONNECTION WITH OUR WORK ALL RIGHTS OF DESIGN AND INVENTION ARE RESERVED THIS IS AN ELECTRONICALLY GENERATED DOCUMENT - DO NOT SCALE THIS PRINT			RFP	CAD FILE 100166		SIZE	DRAWING NO.	PAGE	OF	REV.
			DIST	WP		A	100166			6

THREE PHASE-DUAL VOLTAGE WITH THERMAL PROTECTOR

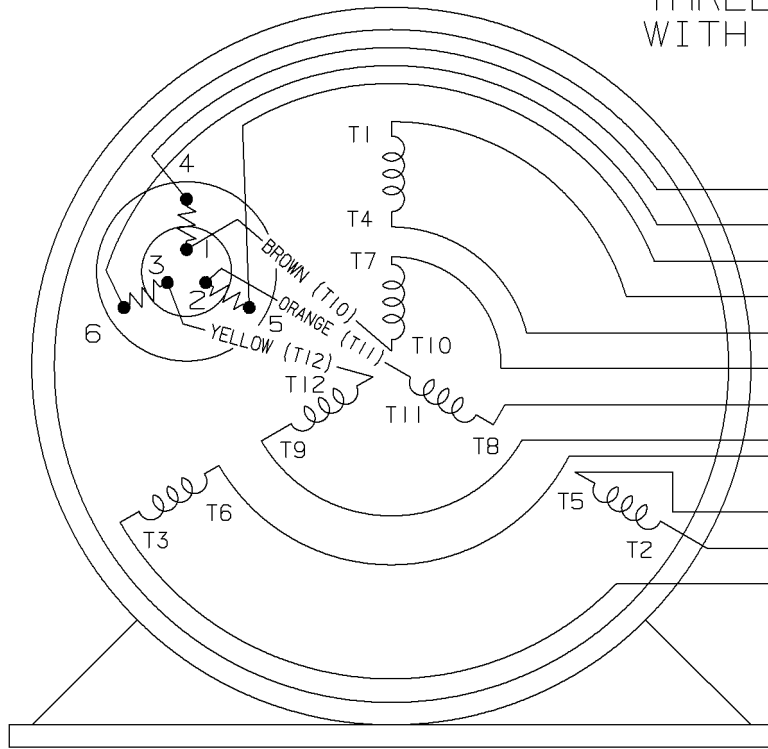

VIEW OF TERMINAL END

- (T14) BROWN
- (T16) YELLOW
- (T15) ORANGE
- (T1) RED
- T4
- T7
- T8
- T9
- T6
- T5
- (T2) BLUE
- (T3) BLACK

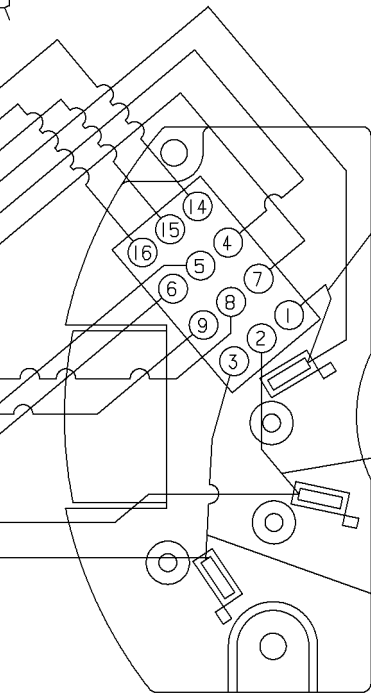

VIEWING BOTTOM OF TERMINAL BOARD

RED
 NUMBERS SHOWN ON TERM BOARD ARE FOR REF. ONLY.
 (NUMBERS DO NOT APPEAR ON PARTS.)

BLUE
 BLACK

TO CHANGE VOLTAGE, PULL PLUG, ROTATE 180° AND REINSERT

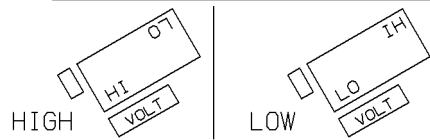

CONNECT LINES TO L1, L2 & L3

NOTE:
 ACTUAL PROTECTORS TERMINAL LOCATIONS FOR LEAD CONNECTIONS

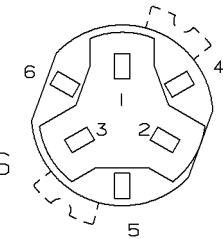

4	06-26-1995	1,2,3 WERE SWITCHED WITH 4,5,6 ON THE TERMINAL CN 20644	BR	✓ MAX. SURFACE ROUGHNESS UNLESS NOTED OTHERWISE	UNLESS OTHERWISE SPECIFIED DIMENSIONS ARE IN INCHES TOL. ON XX±.02 XXX±.005 XXXX±.0005 ANGLES± 7°30"			
3	05-18-1994	ADDED ACTUAL PROTECTOR VIEW CN 17481	KL	MATL SPEC				DRAWN BY RM 07-20-1993
2	07-20-1993	REDRAWN ON CADD, ORIGINAL LOST. REV. VCD TO COLORED LEADS CNI3741	RM	FINISH				CHKD BY ET 07-20-1993
REV	DATE	CHANGE	NAME	REFERENCE DRW.	WAUSAU, WISCONSIN 54401			
				PART NAME CONNECTION DIAGRAM 3Ø - DUAL VOLTAGE MOTOR	DRWG NO A- 102007-1			

SHOP BOOK

PURCHASED

DISTRIBUTION - WA - LB - WP - LM - BR

CADD FILE NO.

102007-1

** Subject to change without notice.