

PRODUCT INFORMATION PACKET

Model No: 056T34F5302
Catalog No: D392
3/4, 3450, TEFC, 56C, 3/60/208-230/460
Totally Enclosed Fan Cooled (TEFC)



Regal and Marathon are trademarks of Regal Beloit Corporation or one of its affiliated companies.
©2018 Regal Beloit Corporation, All Rights Reserved. MC017097E



Nameplate Specifications

Output HP	0.75 Hp	Output KW	0.56 kW
Frequency	60 Hz	Voltage	208-230/460 V
Current	3.0-3.2/1.6 A	Speed	3450 rpm
Service Factor	1.15	Phase	3
Efficiency	74 %	Duty	Continuous
Insulation Class	F	Design Code	B
KVA Code	N	Frame	56C
Enclosure	Totally Enclosed Fan Cooled	Overload Protector	No
Ambient Temperature	40 °C	Drive End Bearing Size	6203
Opp Drive End Bearing Size	6203	UL	Recognized
CSA	Y	CE	Y
IP Code	43		

Technical Specifications

Electrical Type	Squirrel Cage Induction Run	Starting Method	Across The Line
Poles	2	Rotation	Reversible
Mounting	Bolt-on Base	Motor Orientation	Horizontal Or Up Or Down
Drive End Bearing	Ball	Opp Drive End Bearing	Ball
Frame Material	Rolled Steel	Shaft Type	NEMA 56
Overall Length	11.81 in	Frame Length	6.56 in
Shaft Diameter	0.625 in	Shaft Extension	2.06 in
Assembly/Box Mounting	F1 Only		
Outline Drawing	A-100141-656	Connection Diagram	A-EE7308

This is an uncontrolled document once printed or downloaded and is subject to change without notice. Date Created: 07/02/2018

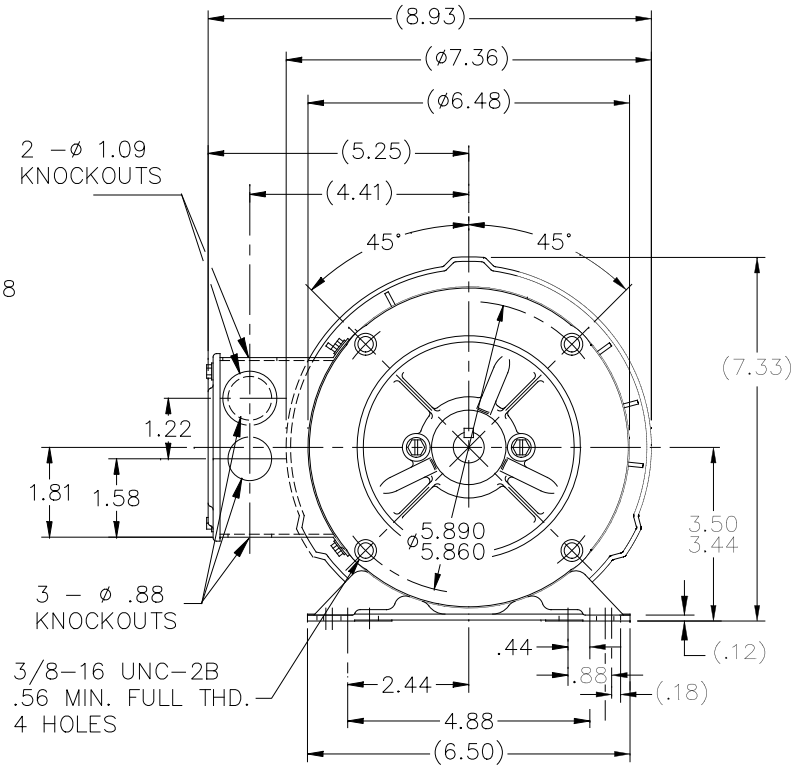
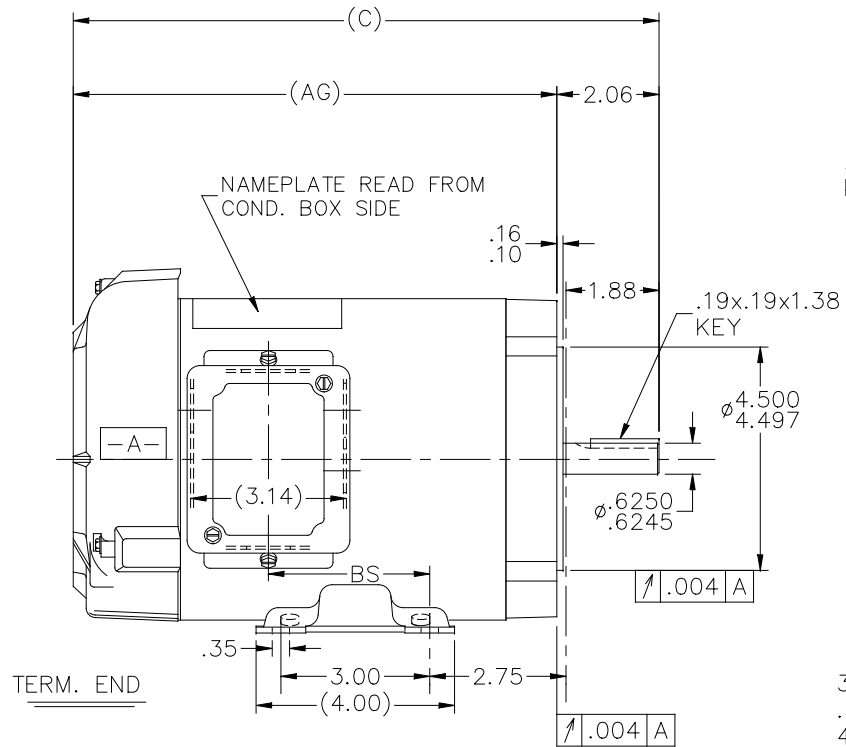

DASH	C	AG	BS	DASH	C	AG	BS
606	11.31	9.25	2.75	756	12.81	10.75	4.25
656	11.81	9.75	3.25	806	13.31	11.25	4.75
706	12.31	10.25	3.75	856	13.81	11.75	5.25

NOTES: CONDUIT BOX CAN BE ROTATED 180° REMOVABLE BASE

NO.	REVISION	BY & DATE	CHK	ANG	FINISH	TOLERANCES UNLESS SPECIFIED	
						DEC.	INCHES
7	ADDED 806 DASH NUMBER	PVR 05-19-2016	.XX	±.03	TITLE OUTLINE	.X	±.1
6	REDRAWN IN AUTOCAD	TAT 06-29-2004	ML	.XXX	56 FR - BB - TEFC - 'C' FACE	.XX	±.03
5	REDRAWN ON CADD	BLR 05-27-1997	.XXXX	±.0005	MAT'L.	.XXX	±.005
			CHK	ANG	±7'30"	.XXXX	±.0005

		DRAWN BLR 05-27-1997	
		CHK ML 05-27-1997	
		APPD GK 05-27-1997	
		SCALE 5=16	
		REF	
		FMF	
		PREV	
THIS DRAWING IN DESIGN AND DETAIL IS OUR PROPERTY AND MUST NOT BE USED EXCEPT IN CONNECTION WITH OUR WORK ALL RIGHTS OF DESIGN AND INVENTION ARE RESERVED THIS IS AN ELECTRONICALLY GENERATED DOCUMENT - DO NOT SCALE THIS PRINT		RFP	CAD FILE 100141
		DIST WP	
SIZE	DRAWING NO.	PAGE	OF
A	100141		
		REV.	
		7	

EE7308

THREE PHASE
DUAL VOLTAGE MOTOR



VIEW OF TERMINAL END

REF.
WINDING DIAGRAM

T8Y, T2Y, T2BL, T4BX, T2EC, T2G
T6BZ, T2B, T6BL, T4AV, T6B, T4B

OPTIONAL CORD
CONNECTION

L1 — WHITE
L2 — RED
L3 — BLACK

NO.	REVISION	BY & DATE	CHK	ANG	TOLERANCES UNLESS SPECIFIED		FINISH	DRAWN RM 11/20/1990				
					DEC.	INCHES						
5	CHG TO REGAL LOGO	SL 09/10/2015	AB					CHK ML 11/21/1990				
4	REVISED IEC NOTATIONS	MSG 11/15/2011	CMN	.X	±.1			APPD SAS 04/24/2003				
3	ADDED IEC NOTATIONS... (U1), (V1) ETC. MU95194	MSG 5/10/2010	MJS	.XX	±.02			SCALE 1=1				
2	ADDED THE OPTIONAL CORD CONNECTION MU46318	RDH 04/24/2003	DRS	.XXX	±.005		TITLE CONNECTION DIAGRAM 3Ø - DUAL VOLTAGE MOTOR	REF				
1	REDRAWN	RM 11/20/1990		.XXXX	±.0005		MAT'L.	FMF				
					±7'30"			PREV				
THIS DRAWING IN DESIGN AND DETAIL IS OUR PROPERTY AND MUST NOT BE USED EXCEPT IN CONNECTION WITH OUR WORK ALL RIGHTS OF DESIGN AND INVENTION ARE RESERVED THIS IS AN ELECTRONICALLY GENERATED DOCUMENT - DO NOT SCALE THIS PRINT							RFP	CAD FILE ee7308	SIZE A	DRAWING NO. EE7308	PAGE OF 5	REV. 5
							DIST WP					



FORM 3531 REV.3 02/07/99

** Subject to change without notice.