

PRODUCT INFORMATION PACKET

marathon[®]
Motors

Model No: 145TTDR16330
Catalog No: GT2404
1 1/2,1800,DP,145JPV,3/60/230/460
JP



Regal and Marathon are trademarks of Regal Beloit Corporation or one of its affiliated companies.
©2018 Regal Beloit Corporation, All Rights Reserved. MC017097E

REGAL[®]



Nameplate Specifications

Output HP	1.50 Hp	Output KW	1.1 kW
Frequency	60 Hz	Voltage	230/460 V
Current	4.4/2.2 A	Speed	1755 rpm
Service Factor	1.15	Phase	3
Efficiency	86.5 %	Duty	Continuous
Insulation Class	F	Design Code	B
KVA Code	M	Frame	145JP
Enclosure	Drip Proof	Overload Protector	No
Ambient Temperature	40 °C	Drive End Bearing Size	6206
Opp Drive End Bearing Size	6203	UL	Recognized
CSA	Y	CE	Y
IP Code	22		

Technical Specifications

Electrical Type	Squirrel Cage Inverter Rated	Starting Method	Line Or Inverter
Poles	4	Rotation	Reversible
Mounting	Rigid base	Motor Orientation	Horizontal
Drive End Bearing	Ball	Opp Drive End Bearing	Ball
Frame Material	Rolled Steel	Shaft Type	JP
Overall Length	18.18 in	Frame Length	9.06 in
Shaft Diameter	0.875 in	Shaft Extension	7.31 in
Assembly/Box Mounting	F1 Only		
Outline Drawing	A-100132-906	Connection Diagram	A-EE7308

This is an uncontrolled document once printed or downloaded and is subject to change without notice. Date Created: 06/29/2018

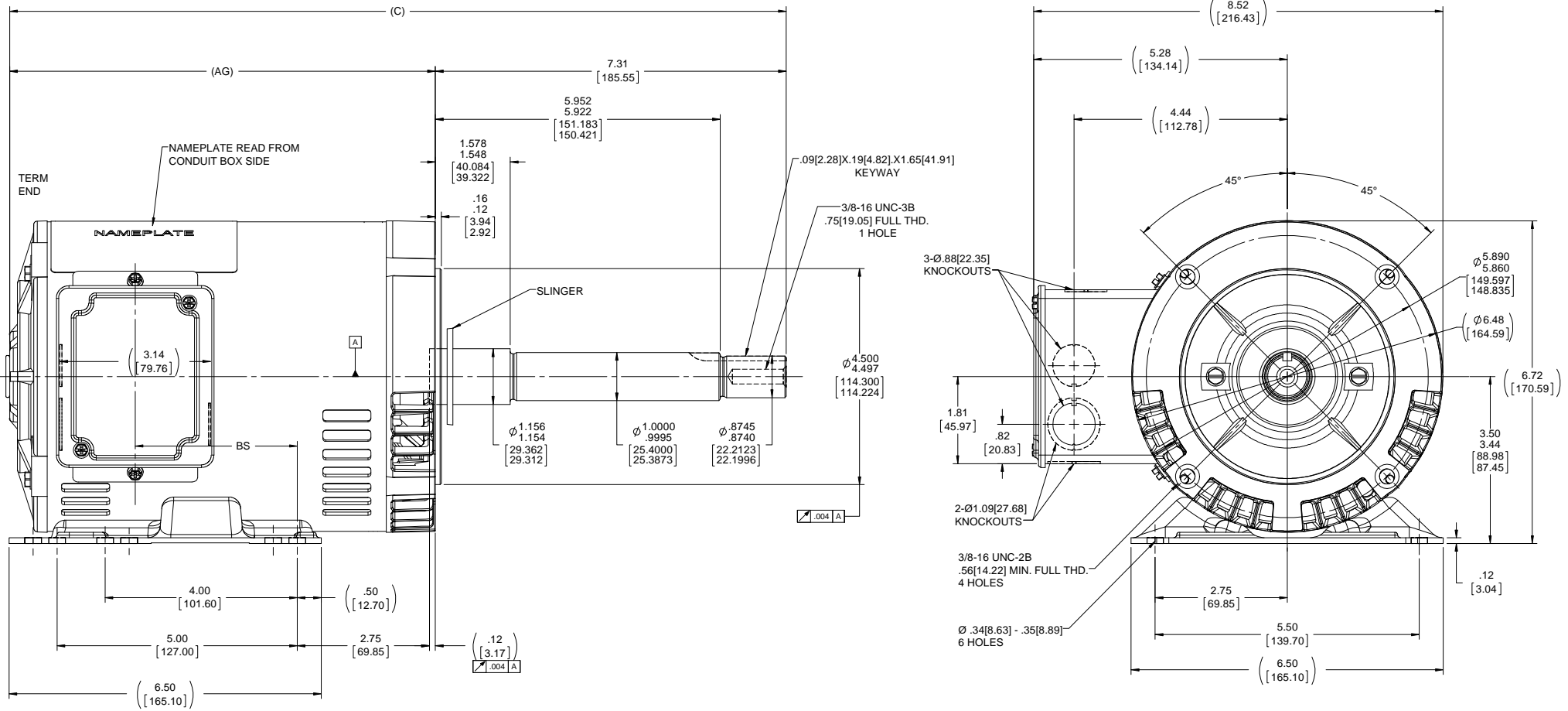

DASH NO.	"C"	"AG"	"BS"
706	16.17[410.71]	8.87[225.29]	3.37[85.59]
756	16.67[423.41]	9.37[237.99]	3.87[98.29]
806	17.17[436.11]	9.87[250.69]	4.37[110.99]
856	17.67[448.81]	10.37[263.39]	4.87[123.69]
906	18.17[461.51]	10.87[276.09]	5.37[136.39]

NOTES:
CONDUIT BOX CAN BE ROTATED IN 180° STEPS.

DRAWING REVISION ECO-0143026	REVISION BY A. KEETHA PST	DATE 04/11/2018	TOLERANCES UNLESS OTHERWISE SPECIFIED: FRACTIONS: .001, .005, .010, .015, .020, .030, .040, .050, .060, .070, .080, .090, .100, .125, .150, .200, .250, .300, .375, .500, .625, .750, .875, 1.000, 1.250, 1.500, 2.000, 2.500, 3.000, 3.750, 4.500, 5.000, 6.000, 7.000, 8.000, 9.000, 10.000 DECIMALS: .001, .005, .010, .015, .020, .030, .040, .050, .060, .070, .080, .090, .100, .125, .150, .200, .250, .300, .375, .500, .625, .750, .875, 1.000, 1.250, 1.500, 2.000, 2.500, 3.000, 3.750, 4.500, 5.000, 6.000, 7.000, 8.000, 9.000, 10.000 ANGLES: 15, 30, 45, 60, 75, 90, 105, 120, 135, 150, 165, 180, 225, 270, 315, 360	DRAWN BY BRH	DATE 11/02/1995	APPROVED BY GK	DESCRIPTION 140 FR.-BB-DR-PR-.38-C FACE-3P EXT.		
OUTLINE CONVERSION PROJECT			REGAL BELLOI AMERICA, INC. COMPANY AND CUSTOMER PROPERTY INFORMATION IS CONFIDENTIAL AND SHOULD BE KEPT AS SUCH. ANY DISCLOSURE OF THIS INFORMATION TO ANY OTHER PARTY WITHOUT THE WRITTEN PERMISSION OF REGAL BELLOI AMERICA, INC. IS STRICTLY PROHIBITED.	DATE 11/02/1995	MATERIAL 140 FR.-BB-DR-PR-.38-C FACE-3P EXT.	THIRD ANGLE PROJECTION	SIZE D	DRAWING NUMBER 100132	PROCESS/ENG 1

EE7308

THREE PHASE
DUAL VOLTAGE MOTOR



VIEW OF TERMINAL END

REF.
WINDING DIAGRAM

T8Y, T2Y, T2BL, T4BX, T2EC, T2G
T6BZ, T2B, T6BL, T4AV, T6B, T4B

OPTIONAL CORD
CONNECTION

L1 — WHITE
L2 — RED
L3 — BLACK

NO.	REVISION	BY & DATE	CHK	ANG	TOLERANCES UNLESS SPECIFIED		FINISH	DRAWN RM 11/20/1990				
					DEC.	INCHES						
5	CHG TO REGAL LOGO	SL 09/10/2015	AB					CHK ML 11/21/1990				
4	REVISED IEC NOTATIONS	MSG 11/15/2011	CMN	.X	±.1			APPD SAS 04/24/2003				
3	ADDED IEC NOTATIONS... (U1), (V1) ETC. MU95194	MSG 5/10/2010	MJS	.XX	±.02		TITLE CONNECTION DIAGRAM	SCALE 1=1				
2	ADDED THE OPTIONAL CORD CONNECTION MU46318	RDH 04/24/2003	DRS	.XXX	±.005		3Ø - DUAL VOLTAGE MOTOR	REF				
1	REDRAWN	RM 11/20/1990		.XXXX	±.0005		MAT'L.	FMF				
					±7'30"			PREV				
THIS DRAWING IN DESIGN AND DETAIL IS OUR PROPERTY AND MUST NOT BE USED EXCEPT IN CONNECTION WITH OUR WORK ALL RIGHTS OF DESIGN AND INVENTION ARE RESERVED THIS IS AN ELECTRONICALLY GENERATED DOCUMENT - DO NOT SCALE THIS PRINT							RFP	CAD FILE ee7308	SIZE A	DRAWING NO. EE7308	PAGE OF 5	REV. 5
							DIST WP					



CERTIFICATION DATA SHEET

Model#: 145TTDR16330 AA **WINDING#:** ZT4258 NONE 3
CONN. DIAGRAM: A-EE7308 **ASSEMBLY:** F1 ONLY
OUTLINE: A-100132-906

TYPICAL MOTOR PERFORMANCE DATA

HP	KW	SYNC. RPM	F.L. RPM	FRAME	ENCLOSURE	KVA CODE	DESIGN
1 1/2&1	1.12&.75	1800	1755&1465	145JP	DP	M	B

PH	Hz	VOLTS	FL AMPS	START TYPE	DUTY	INSL	S.F	AMB°C	ELEVATION
3	60/50	230/460#190/ 380	4.4/2.2&4.2/ 1	LINE OR INVERTER	CONTINUOU S	F3	1.15/1.0	40	3300

FULL LOAD EFF: 86.5&85.5	3/4 LOAD EFF: 86	1/2 LOAD EFF: 83.8	GTD. EFF	ELEC. TYPE	NO LOAD AMPS
FULL LOAD PF: 75&70	3/4 LOAD PF: 67	1/2 LOAD PF: 54.5	84	SQ CAGE INV RATED	2.5 / 1.3

F.L. TORQUE	LOCKED ROTOR AMPS	L.R. TORQUE	B.D. TORQUE	F.L. RISE°C
4.5 LB-FT	39.6 / 19.8	16.65 LB-FT 370	21.65 LB-FT 481	32

SOUND PRESSURE @ 3 FT.	SOUND POWER	ROTOR WK^2	MAX. WK^2	SAFE STALL TIME	STARTS /HOUR	APPROX. MOTOR WGT
56 dBA	66 dBA	0 LB-FT^2	10 LB-FT^2	20 SEC.	2	43 LBS.

***** SUPPLEMENTAL INFORMATION *****

DE BRACKET TYPE	ODE BRACKET TYPE	MOUNT TYPE	ORIENTATION	SEVERE DUTY	HAZARDOUS LOCATION	DRIP COVER	SCREENS	PAINT
C-FACE	STANDARD	RIGID	HORIZONTAL	FALSE	NONE	PROVISIONS ONLY	NONE	BLUE (POWDER)

BEARINGS		GREASE	SHAFT TYPE	SPECIAL DE	SPECIAL ODE	SHAFT MATERIAL	FRAME MATERIAL
DE	OPE	POLYREX EM	JP	NONE	NONE	1144 STRESSPROOF (C-223)	ROLLED STEEL
BALL	BALL						
6206	6203						

THERMO-PROTECTORS				THERMISTORS	CONTROL	SPACE /n HEATERS
THERMOSTATS	PROTECTORS	WDG RTDs	BRG RTDs			
NONE	NOT	NONE	NONE	NONE	FALSE	NONE VOLTS

If Inverter equals NONE, contact factory for further information

INVERTER TORQUE: CONSTANT 2:1
INV. HP SPEED RANGE: NONE
ENCODER: NONE
NONE NONE
NONE NONE PPR
BRAKE: NONE NONE
NONE P/N NONE
NONE NONE
- FT-LB NONE V NONE Hz

*
N
O
T
E
S
*

DATE: 06/23/2017 04:53:55 AM
 FORM 3531 REV.3 02/07/99
 ** Subject to change without notice.

Data Sheet



145TTDR16330

Submittal

Data @ 460 V

Date: 6/20/2017

Customer:
 Attention: FAREEDA DUDEKULA

Submitted by:

Load	Motor Load Data					LR		
	0%	25%	50%	75%	100%		115%	125%
Current (Amps)	1.26	1.30	1.50	1.80	2.20	2.40	2.50	19.8
Torque (ft-lb)	0.00	1.10	2.20	3.4	4.5	5.2	5.7	16.7
RPM	1800	1788	1775	1765	1755	1745	1740	0
Efficiency (%)		75.3	83.8	86.0	86.5	86.0	86.0	
P.F. (%)	9.3	35.2	54.5	67.0	75.0	78.5	80.0	88.0

Motor Speed Data

	LR	Pull-Up	BD	Rated	Idle
Speed (rpm)	0	120	1220	1755	1800
Current (Amps)	19.8	20.2	13.1	2.20	1.26
Torque (ft-lb)	16.7	16.6	21.7	4.5	0.00

Information Block

HP	1.5			
Sync. RPM	1800			
Frame	145			
Enclosure	DP			
Construction	TDR			
Voltage	30/460#/190/38 V			
Frequency	60 HZ			
Design	A			
LR Code letter	M			
Service Factor	1.15			
Temp Rise @ FL	28 °C			
Duty	CONT			
Ambient	40 °C			
Elevation	1,000 feet			
Rotor/Shaft wk ^e	0.00 Lb-Fe			
Rel Wdg	Z14258 NONE			
Sound Pressure @ 1M	56 dbA			
VFD Rating	CONSTANT 2:1			
Outline Dwg	A-100132-906			
Conn. Diag	A-EE7308			
Additional Specifications:				
EQUIVCKT (OHMS/ PHASE)				
R1	R2	X1	X2	Xm
0.00000	0.00000	0.00000	0.00000	0.00000

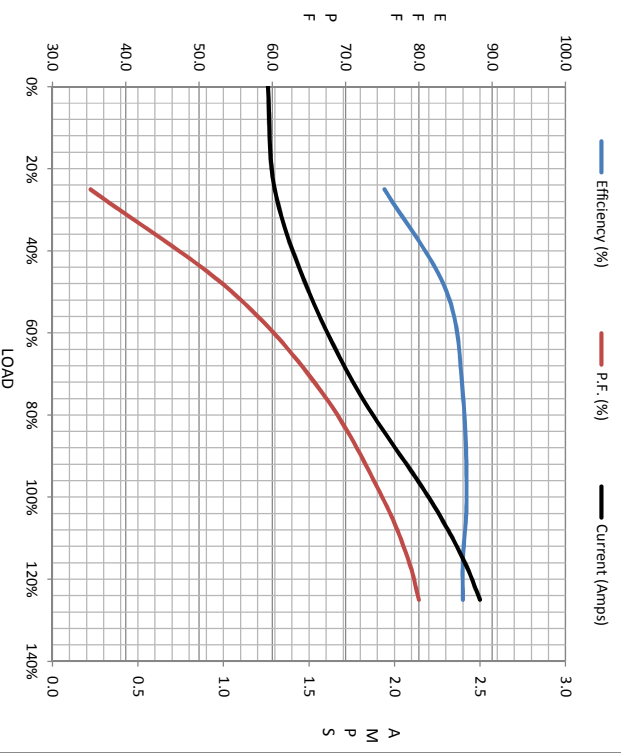

Speed - Torque Curve

