

1-A SERIES - 1/28 HP

APPLICATIONS

Small submersible oil-filled pump with epoxy coated cast aluminum housing. For commercial, industrial and home applications including statuary fountains, water displays, air conditioners, machine tool coolants, and many other applications where liquid must be transferred or recirculated.

FEATURES

- Epoxy coated die-cast aluminum housing
- Oil-filled motor housing
- 7-foot maximum lift
- Screened inlet
- 1/4-inch MNPT discharge
- Impedance protected motor
- For submersible use only



1-A



SERIES SPECIFICATIONS

Item No.	Model	Discharge	Listing(s)	HP	Volts	Hz	Amps	Watts	Gallons per hour (Liter per hour) @ Height			Shut-Off	PSI	Cord	Weight lbs (Kg)
									1'	3'	5'				
500500	1-AA-18	1/4" MNPT	UL/CSA	1/200	115	60	1.1	70	170 (644)	140 (530)	100 (379)	7' (2.1 m)	3.0	18' (5.5 m)	4.17 (1.89 Kg)
500203	1-A	1/4" MNPT	UL	1/200	115	60	1.1	70	170 (644)	140 (530)	100 (379)	7' (2.1 m)	3.0	6' (1.8 m)	3.33 (1.51 Kg)
500286	1-AT	1/4" MNPT	UL/CSA	1/200	115	60	1.1	70	170 (644)	140 (530)	100 (379)	7' (2.1 m)	3.0	10' (3 m)	3.50 (1.59 Kg)

SMALL SUBMERSIBLE PUMPS

1-A SERIES - 1/28 HP

ENGINEERING DATA

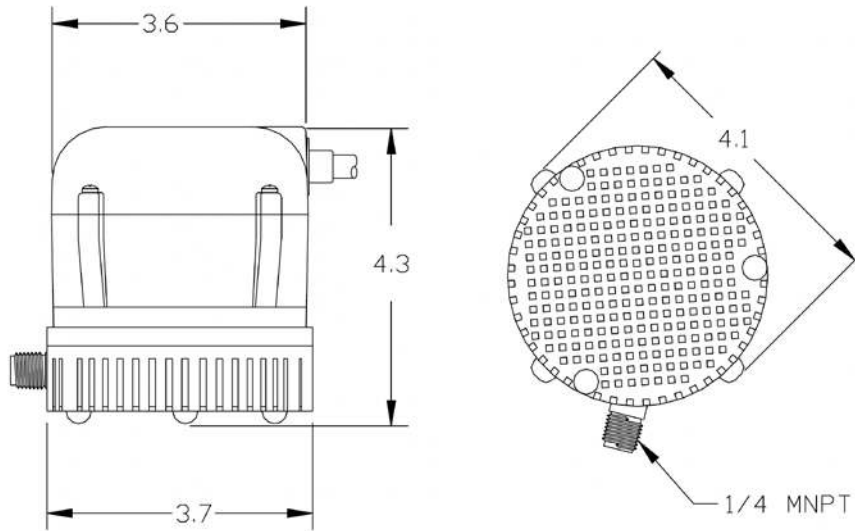

PERFORMANCE DATA

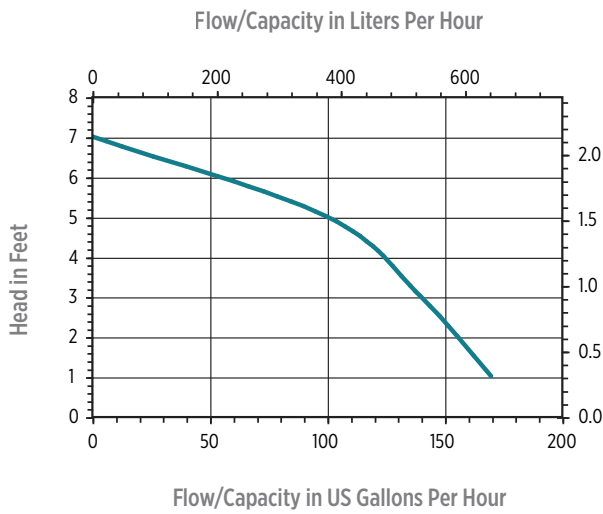

REPLACEMENT PARTS

Volute	101350
Impeller	101441
Screen	101901
Elbow	943070

