

# MYERS® ED33 SERIES

The Myers® ED33 series sink pump system is a time- and money-saving solution. Fast, easy on-floor installation – no need to dig a sump pit. This pre-packaged sink pump system includes a heavy-duty cast iron pump and corrosion-resistant poly basin for years of extended service in a wide variety of applications.

## APPLICATIONS

Laundry trays, wet bars, beautician or utility sinks, dehumidifiers, air-conditioning units

## SPECIFICATIONS

**Capacities** – 48 GPM (182 LPM)  
**Shut-off Head** – 24' (7.3 m)  
**Operation** – On: 6-1/2" (165 mm)  
 Off: 2" (50 mm)  
**Solids Handling** – 1/2 (12.7 mm)  
**Liquids Handling** – Drainage effluent  
**Intermittent Liquid Temperature** –  
 Up to 130°F (54°C)  
**Motor/Electrical Data** – 1/3 HP, 115V,  
 9.8 FLA, 1Ø, 60Hz  
**Acceptable pH Range** – 5-9  
**Shaft Seal** – Carbon and ceramic  
**Housing** – Cast iron  
**Power Cord** – 10' (3 m), grounded SJTW,  
 SJTW-A  
**Discharge, NPT** – 1-1/2" (38 mm)



## FEATURES

### On-ground Installation

Without the requirement of digging a sump pit, the system quickly sets up on any solid surface

### Heavy-duty Basin Design

Corrosion-resistant, heavy-duty poly basin with curved edge design for increased strength and longer service life

### High-Flow Discharge

1-1/2" (38mm) NPT discharge

### Manual or Automatic

Automatic vertical switch with piggy-back plug for manual operation

### Years of Service

System includes the dependable and tested MDC series pump

### Industry-proven Pump Design

- Oil-cooled motor for continuous lubrication and heat dissipation
- Long-life carbon/ceramic seal protects motor against water leakage
- Internal heat sensor provides overload protection and automatic reset
- Shaded pole motor eliminates failure-prone internal relays and switches

## ORDERING INFORMATION

Catalog Number	HP	Volts	Phase/ Cycles	Amps	Discharge Size	Switch Type	Cord Length	Approx. Wt. Lbs.
ED33V1	1/3	115	1/60	9.8	1-1/2"	Vertical Automatic	10'	34

# MYERS® ED33 SERIES

## DIMENSIONS

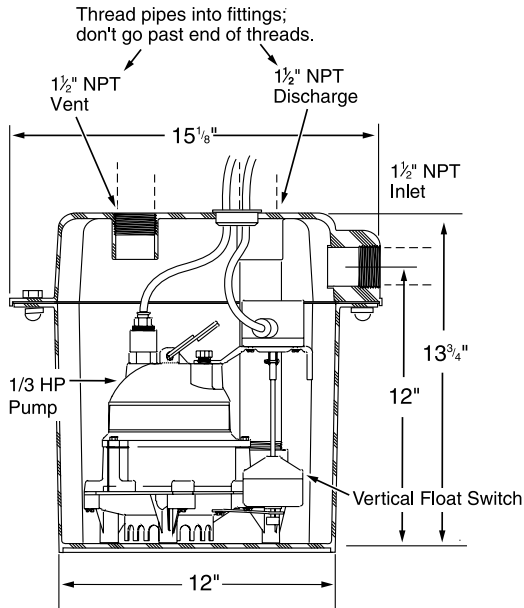

## PUMP PERFORMANCE

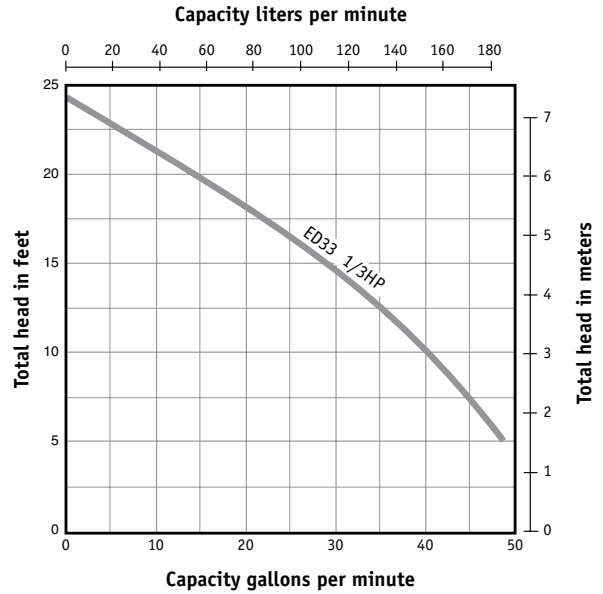

USA  
293 WRIGHT STREET, DELAVAN, WI 53115 WWW.FEMEYERS.COM  
PH: 888-987-8677 ORDERS FAX: 800-426-9446

CANADA  
269 TRILLIUM DRIVE, KITCHENER, ONTARIO, CANADA N2G 4W5  
PH: 519-606-5484 ORDERS FAX: 800-426-9446

Because we are continuously improving our products and services, Pentair reserves the right to change specifications without prior notice.