

# PRODUCT INFORMATION PACKET

Model No: 254TTDX16086  
Catalog No: M808B  
7.5,1200,DP,254HPV,3/6/230/460  
Vertical Solid Shaft P-Base



Regal and Marathon are trademarks of Regal Beloit Corporation or one of its affiliated companies.  
©2018 Regal Beloit Corporation, All Rights Reserved. MC017097E



### Nameplate Specifications

Output HP	<b>7.50 Hp</b>	Output KW	<b>5.6 kW</b>
Frequency	<b>60 Hz</b>	Voltage	<b>230/460 V</b>
Current	<b>21.4/10.7 A</b>	Speed	<b>1173 rpm</b>
Service Factor	<b>1.15</b>	Phase	<b>3</b>
Efficiency	<b>91.2 %</b>	Duty	<b>Continuous</b>
Insulation Class	<b>F</b>	Design Code	<b>B</b>
KVA Code	<b>H</b>	Frame	<b>254HPV</b>
Enclosure	<b>Drip Proof</b>	Overload Protector	<b>No</b>
Ambient Temperature	<b>40 °C</b>	Drive End Bearing Size	<b>6309</b>
Opp Drive End Bearing Size	<b>6208</b>	UL	<b>Recognized</b>
CSA	<b>Y</b>	CE	<b>Y</b>
IP Code	<b>22</b>		

### Technical Specifications

Electrical Type	<b>Squirrel Cage Induction Run</b>	Starting Method	<b>Across The Line</b>
Poles	<b>6</b>	Rotation	<b>Reversible</b>
Mounting	<b>Round</b>	Motor Orientation	<b>SHAFT DOWN</b>
Drive End Bearing	<b>BALL</b>	Opp Drive End Bearing	<b>BALL</b>
Frame Material	<b>Rolled Steel</b>	Shaft Type	<b>HP</b>
Overall Length	<b>24.30 in</b>	Frame Length	<b>15.15 in</b>
Shaft Diameter	<b>1.125 in</b>	Shaft Extension	<b>2.75 in</b>
Assembly/Box Mounting	<b>F1/F2 CAPABLE</b>		
Outline Drawing	<b>SS86538-1515</b>	Connection Diagram	<b>EE7308</b>

This is an uncontrolled document once printed or downloaded and is subject to change without notice. Date Created: 10/30/2018

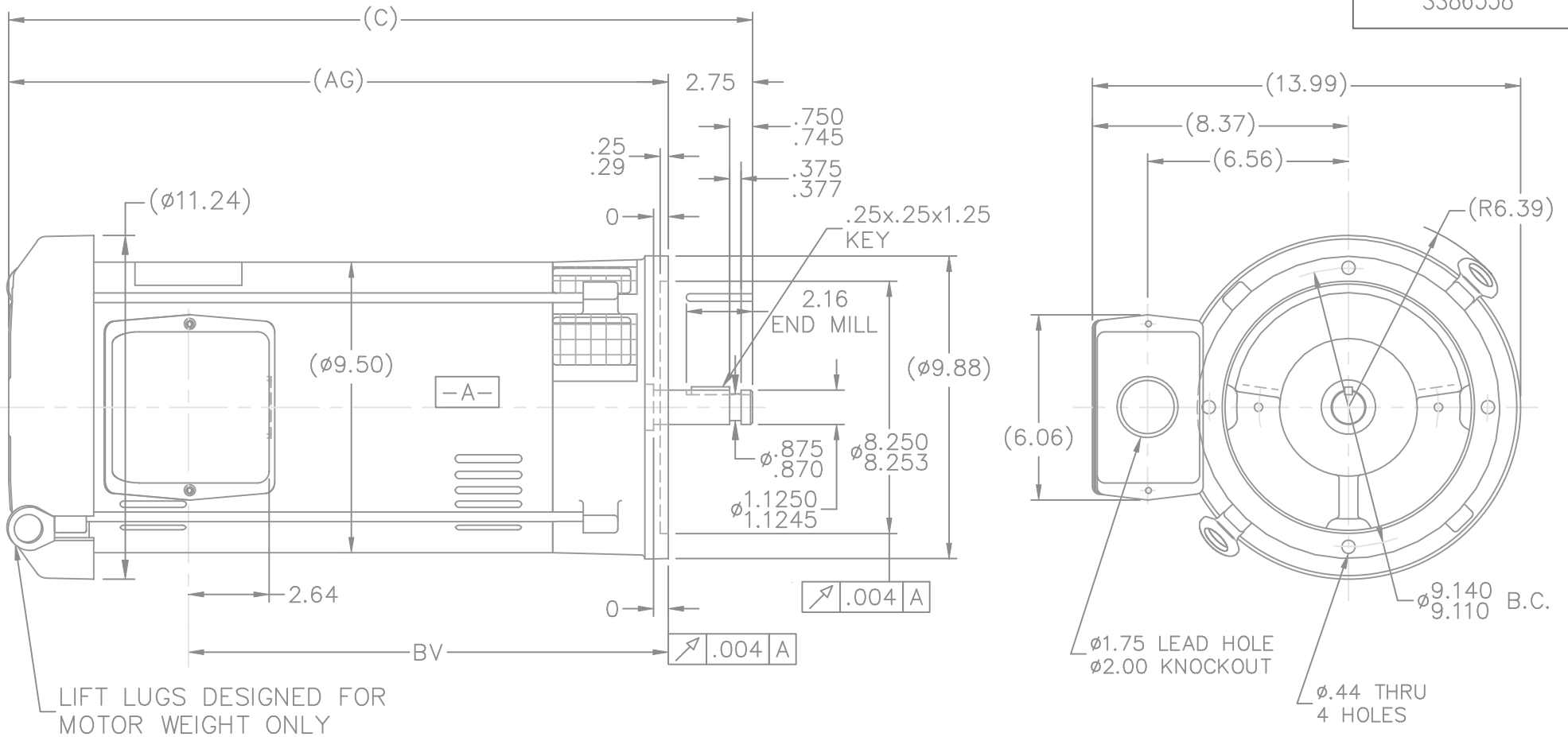

DASH	FR.	C	BV	AG
1340	254HP	22.55	13.93	19.80
1515	254/256HP	24.30	15.68	21.55

- NOTES:  
 1. NAMEPLATE TO BE READ FROM SHAFT EXT. END OF MOTOR.  
 2. BOX CAN BE MOUNTED IN 90° STEPS.

				TOLERANCES UNLESS SPECIFIED			DRAWN KL 11-24-1993	
NO.	REVISION	BY & DATE	CHK	ANG	±"		FINISH	PREV
8	UPDATED DRAWING	TJW 04/27/2007		DEC.	INCHES	TITLE OUTLINE 250HP FR. - BB - TS - 'P' BASE  MAT'L.  FINISH	CHK	ML 11-29-1993
7	REDRAWN IN AUTOCAD	TAT 07-22-2004	ML	.X	±.1		APPD	DRN 11-29-1993
6	CLARIFIED REVISION HISTORY AND BOX ROT. CN28427	CAV 02-17-2000		.XX	±.03		SCALE	1=5
5	UPDATED CONDUIT BOX CN 28427	TJB 01-31-2000		.XXX	±.005		REF	
4	-1515 WAS FOR 256HP FR. ONLY CN 18683	KL 10-11-1994		.XXXX	±.0005		FMF	
				RFP		CAD FILE ss86538	SIZE	DRAWING NO. PAGE OF REV.
				DIST	LB		A	SS86538 8

THIS DRAWING IN DESIGN AND DETAIL IS OUR PROPERTY AND MUST NOT BE USED EXCEPT IN CONNECTION WITH OUR WORK ALL RIGHTS OF DESIGN AND INVENTION ARE RESERVED THIS IS AN ELECTRONICALLY GENERATED DOCUMENT - DO NOT SCALE THIS PRINT

EE7308

THREE PHASE  
DUAL VOLTAGE MOTOR



VIEW OF TERMINAL END

REF.  
WINDING DIAGRAM

T8Y, T2Y, T2BL, T4BX, T2EC, T2G  
T6BZ, T2B, T6BL, T4AV, T6B, T4B

OPTIONAL CORD  
CONNECTION

L1 — WHITE  
L2 — RED  
L3 — BLACK

NO.	REVISION	BY & DATE	CHK	ANG	TOLERANCES UNLESS SPECIFIED		FINISH	DRAWN RM 11/20/1990				
					DEC.	INCHES						
5	CHG TO REGAL LOGO	SL 09/10/2015	AB					CHK ML 11/21/1990				
4	REVISED IEC NOTATIONS	MSG 11/15/2011	CMN	.X	±.1			APPD SAS 04/24/2003				
3	ADDED IEC NOTATIONS... (U1), (V1) ETC. MU95194	MSG 5/10/2010	MJS	.XX	±.02		TITLE CONNECTION DIAGRAM	SCALE 1=1				
2	ADDED THE OPTIONAL CORD CONNECTION MU46318	RDH 04/24/2003	DRS	.XXX	±.005		3Ø - DUAL VOLTAGE MOTOR	REF				
1	REDRAWN	RM 11/20/1990		.XXXX	±.0005		MAT'L.	FMF				
					±7'30"			PREV				
THIS DRAWING IN DESIGN AND DETAIL IS OUR PROPERTY AND MUST NOT BE USED EXCEPT IN CONNECTION WITH OUR WORK ALL RIGHTS OF DESIGN AND INVENTION ARE RESERVED THIS IS AN ELECTRONICALLY GENERATED DOCUMENT - DO NOT SCALE THIS PRINT							RFP	CAD FILE ee7308	SIZE A	DRAWING NO. EE7308	PAGE OF 5	REV. 5
							DIST WP					





P.O. BOX 8003  
WAUSAU, WI 54401-8003  
PH. 715-675-3311

DATA VOLTS: 460

CERTIFICATION DATA SHEET

CUSTOMER P.O. #:   
 ORDER #: EE7308 REFERENCE MODEL #: 254TTDX16086  
 CONN. DIAGRAM: TBD CAT #: M808B  
 WINDING: K2156179 NONE 1 CUSTOMER PART #:   
 SPEED: MOUNTING: F1/F2 CAPABLE

TYPICAL MOTOR PERFORMANCE DATA

HP	KW	SYNC RPM	FL RPM	FRAME	ENCLOSURE	TYPE	KVA CODE	DESIGN	
7.5	5.6	1200	1173	254HPV	DP	TDX	H	B	
PH	HZ	VOLTS	AMPS	START TYPE	DUTY	INSL	S.F.	AMB	ELEV.
3	60/50	230/460#190/380	21.4/10.7&17.6/8.8	ACROSS-THE LINE	CONT	F	1.15	40	3300
	F.L. EFF	91.2	3/4 LD EFF	90.7	1/2 LD EFF	89.7	GTD EFF	ELECT. TYPE	
	F.L. PF	71.3	3/4 LD PF	65.1	1/2 LD PF	52.8	90.2	SQ CAGE IND RUN	
F.L. TORQUE	LR AMPS @ 460 V	L.R. TORQUE	B.D. TORQUE	F.L. RISE (°C)					
33.6 LB-FT	63.0	61.5 LB-FT	183%	92.5 LB-FT	275%	27			
@ 3 FT.	POWER	ROTOR WK <sup>2</sup>	MAX. LOAD WK <sup>2</sup>	SAFE STALL TIME	START/SHOUR	MOTOR WGT			
64 DBA	73 DBA	1.30 LB-FT <sup>2</sup>	120 LB-FT <sup>2</sup>	20 SEC.	2	150 LB.			

\*\*\* SUPPLEMENTAL INFORMATION \*\*\*

DE BRACKET TYPE	ODE BRACKET TYPE	MOUNT TYPE	MOTOR ORIENTATION	SEVERE DUTY	HAZARDOUS LOCATION	DRIP COVER	SCREENS	PAINT
P-BASE	STANDARD	ROUND	SHAFT DOWN	NO	NONE	YES	RODENT	BLUE (ENAMEL)
BEARINGS	GREASE	SHAFT TYPE	SPECIAL DE	SPECIAL ODE	SHAFT	MATERIAL	FRAME MATERIAL	
DE BALL 6309	BALL POLYREX EM	HP	NONE	NONE	1045 HOT ROLLED (C-204)	ROLLED STEEL		
THERMOSTATS	PROTECTORS	WDG RTD's	BRG RTD's	THERMISTORS	CONTROL	SPACE HEATERS		
NONE	NOT	NONE	NONE	NONE	FALSE	NA		
R1 (ohms/ph)	R2 (ohms/ph)	X1 (ohms/ph)	X2 (ohms/ph)	Xm (ohms/ph)	VIBRATION (in/sec)	FLOAT		
0.801	0.816	3.58	3.989	49.027	0.150	ODE		

\* INVERTER TORQUE: NONE  
 INV. HP SPEED RANGE: NONE  
 ENCODER: NONE  
 NONE  
 NONE  
 BRAKE: NONE  
 NONE  
 NONE  
 NONE PPR

PREPARED BY: FAREEDA DUDEKULA  
 DATE: 9/11/2018  
 FT-LB: NA  
 VOLTAGE: NONE  
 HZ: UL: V/INS, CONST UL REC

Data Sheet

254TDX16086



Submital  
Data @ 460 V

Date: 9/11/2018  
 Customer: \_\_\_\_\_  
 Attention: \_\_\_\_\_  
 Submitted by: FAREEDA DUDEKULA

Load	Motor Load Data									
	0%	25%	50%	75%	100%	115%	125%	LR		
Current (Amps)	6.0	6.4	7.4	8.9	10.7	12.0	12.9	63.0		
Torque (ft-lb)	0.00	8.2	16.6	25.1	33.6	39.0	42.5	61.5		
RPM	1200	1193	1188	1177	1173	1,162	1,158	0		
Efficiency (%)		84.2	89.7	90.7	91.2	89.9	89.4			
P.F. (%)	5.5	32.6	52.8	65.1	71.3	74.8	76.0	40.5		

Motor Speed Data					Information Block					
LR	Pull-Up	BD	Rated	Idle	HP	Frame	Enclosure	Construction	Voltage	Frequency
					7.5	254182TFC080	DP	TDX	230/460#190/380	60
Speed (RPM)	0	600	1000	1173	1200					
Current (Amps)	63.0	55.0	40.0	10.7	6.0					
Torque (ft-lb)	61.5	55.0	92.5	33.6	0.00					

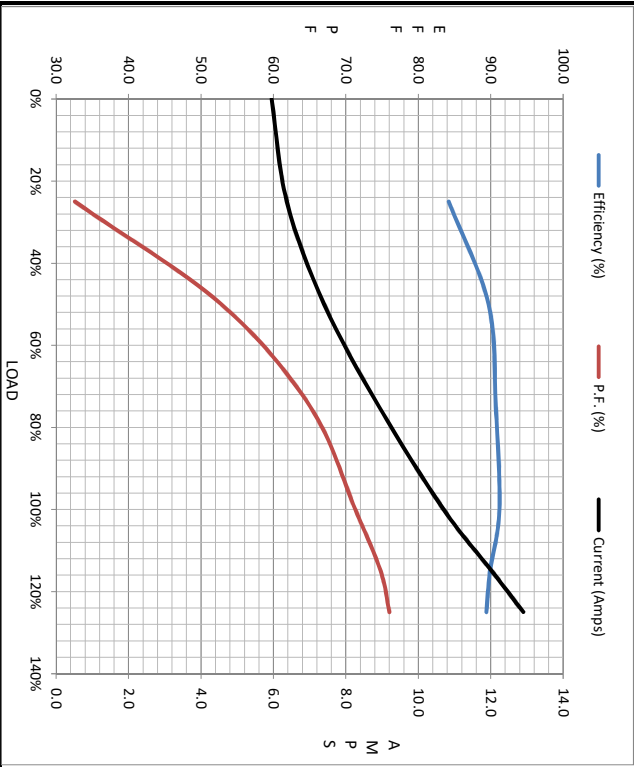

HP	7.5			
Sync. RPM	1200			
Frame	254182TFC080			
Enclosure	DP			
Construction	TDX			
Voltage	230/460#190/380 V			
Frequency	60 Hz			
Design	B			
LR Code letter	H			
Service Factor	1.15			
Temp Rise @ FL	27 °C			
Duty	CONT			
Ambient	40 °C			
Elevation	1,000 feet			
Motor/Shaft wk <sup>2</sup>	1.30 Lb-Ft <sup>2</sup>			
Ret Wdg	K2156179 NONE			
Sound Pressure @ 1M	64 DBA			
VFD Rating	NONE			
Outline Dwg	TBD			
Conn. Diag	EE7308			
Additional Specifications:				
0				
0				
	EQUIV CKT (OHMS / PHASE)			
R1	R2	X1	X2	Xm
0.8010	0.8160	3.5800	3.9690	49.0270

