

PRODUCT INFORMATION PACKET

marathon[®]
Motors

Model No: 286TTGN16546
Catalog No: E564-P
30,1800,EPFC,286T,3/60/230/460
Explosion Proof



Regal and Marathon are trademarks of Regal Beloit Corporation or one of its affiliated companies.
©2018 Regal Beloit Corporation, All Rights Reserved. MC017097E

REGAL[®]



Nameplate Specifications

Output HP	30 Hp	Output KW	22.4 kW
Frequency	60 Hz	Voltage	230/460 V
Current	73.0/36.5 A	Speed	1773 rpm
Service Factor	1.15	Phase	3
Efficiency	94.1 %	Duty	Continuous
Insulation Class	F	Design Code	B
KVA Code	G	Frame	286T
Enclosure	Explosion Proof Fan cooled	Overload Protector	No
Ambient Temperature	40 °C	Drive End Bearing Size	6311
Opp Drive End Bearing Size	6210	UL	No
CSA	N	CE	N
IP Code	54		

Technical Specifications

Electrical Type	Squirrel Cage Inverter Rated	Starting Method	Line Or Inverter
Poles	4	Rotation	Reversible
Mounting	Rigid base	Motor Orientation	Horizontal
Drive End Bearing	Ball	Opp Drive End Bearing	Ball
Frame Material	Cast Iron	Shaft Type	T
Overall Length	27.84 in	Frame Length	14.25 in
Shaft Diameter	1.875 in	Shaft Extension	4.81 in
Assembly/Box Mounting	F1 Only		
Outline Drawing	B-SS311003-1425	Connection Diagram	A-EE7308T

This is an uncontrolled document once printed or downloaded and is subject to change without notice. Date Created: 06/29/2018

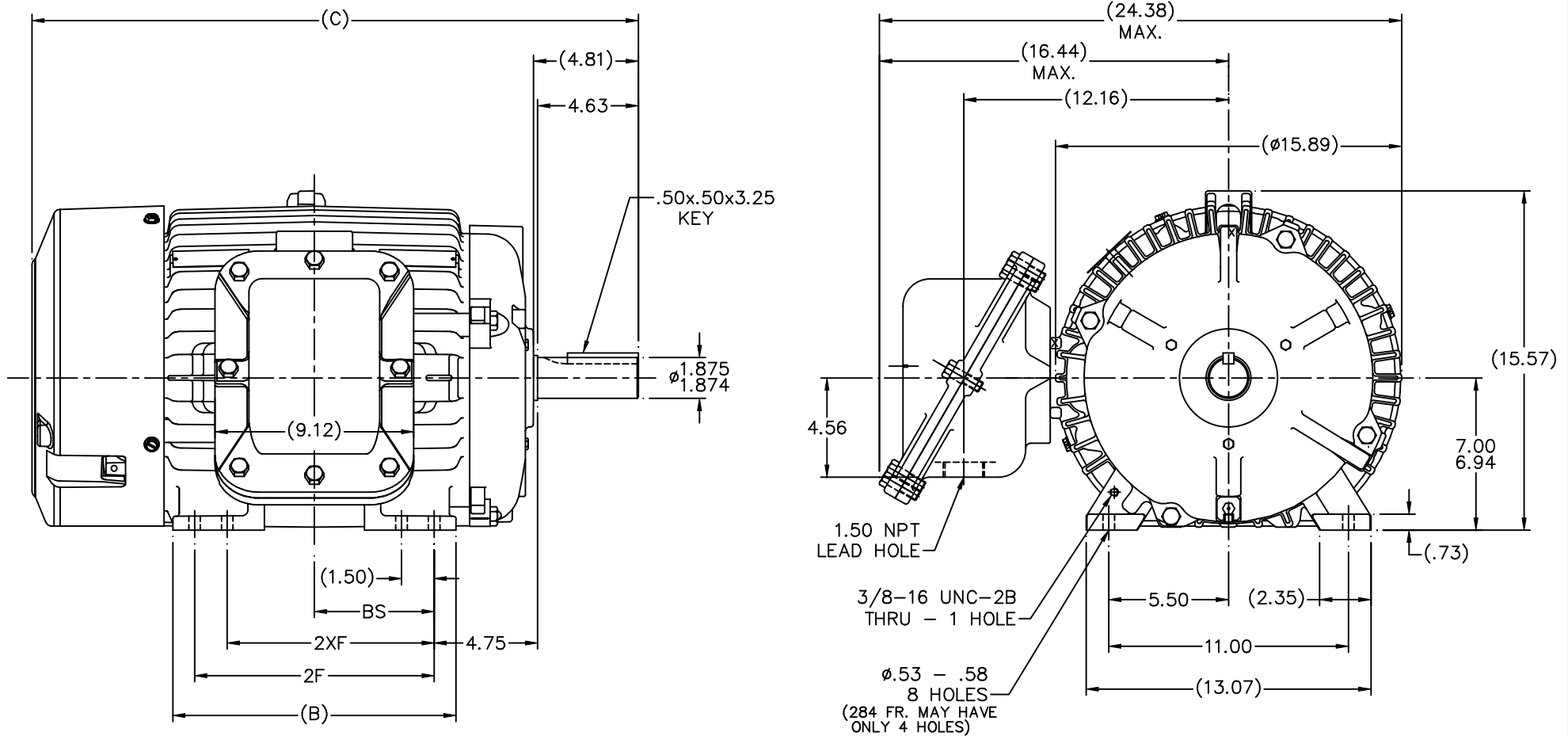

- NOTES:
 1. BOX CAN ONLY BE ROTATED CLOCKWISE UP TO 270° FROM ITS ORIGINAL POSITION.
 2. NAMEPLATE TO BE READ FROM CONDUIT BOX SIDE OF MOTOR.

DASH	FRAME	B	C	2F	2XF	BS
1275	284T	12.50	26.34	9.50		4.75
1425	284/6T	13.00	27.84	11.00	9.50	5.50

5	UPDATED DRAWING	RJW 04-30-2007	TOLERANCES UNLESS SPECIFIED		DRAWN DA 03-12-1999
4	ADDED 284 FRAME TO DASH 1425 MU28939	MJD 02-15-2000	DEC. INCHES		CHK ML 04-15-1999
3	UPDATED C'BOX GEOMETRY PER CASTING		.X ±.1		APPD SW 04-15-1999
	CHANGE CN29010	DRS 01-31-2000	.XX ±.03	TITLE OUTLINE - EXP. PR. - TGN	SCALE 1=4.5
2	REV'D. 'C' DIM. FOR C.I. FAN GUARD		.XXX ±.005	280T FR. - BB - STD - 12.50 LAM.	REF
	REV'D. CONDUIT BOX CN27400-239	DA 07-12-1999	.XXXX ±.0005	MATL	FMF
NO.	REVISION	BY & DATE	CHK ANG ±7'30"	FINISH	PREV
THIS DRAWING IN DESIGN AND DETAIL IS OUR PROPERTY AND MUST NOT BE USED EXCEPT IN CONNECTION WITH OUR WORK ALL RIGHTS OF DESIGN AND INVENTION ARE RESERVED THIS IS AN ELECTRONICALLY GENERATED DOCUMENT - DO NOT SCALE THIS PRINT				RFP	CAD FILE SS311003
				DIST LB-BR	SIZE B DRAWING NO. SS311003 PAGE OF 5

HIGH VOLTAGE



**NOTE FOR FACTORY USE ONLY:
 TO SURGE TEST FOR COMMON CONNECT:
 HIGH VOLT: CONNECT P1 TO T1
 THEN P2 TO L1
 LOW VOLT: CONNECT P1 TO T1 & T7,
 THEN P2 TO L1**

LOW VOLTAGE



NOTE: LEAD'S COLOR CAN BE YELLOW OR WHITE FOR MT2 PLANT

THREE PHASE DUAL VOLTAGE MOTOR

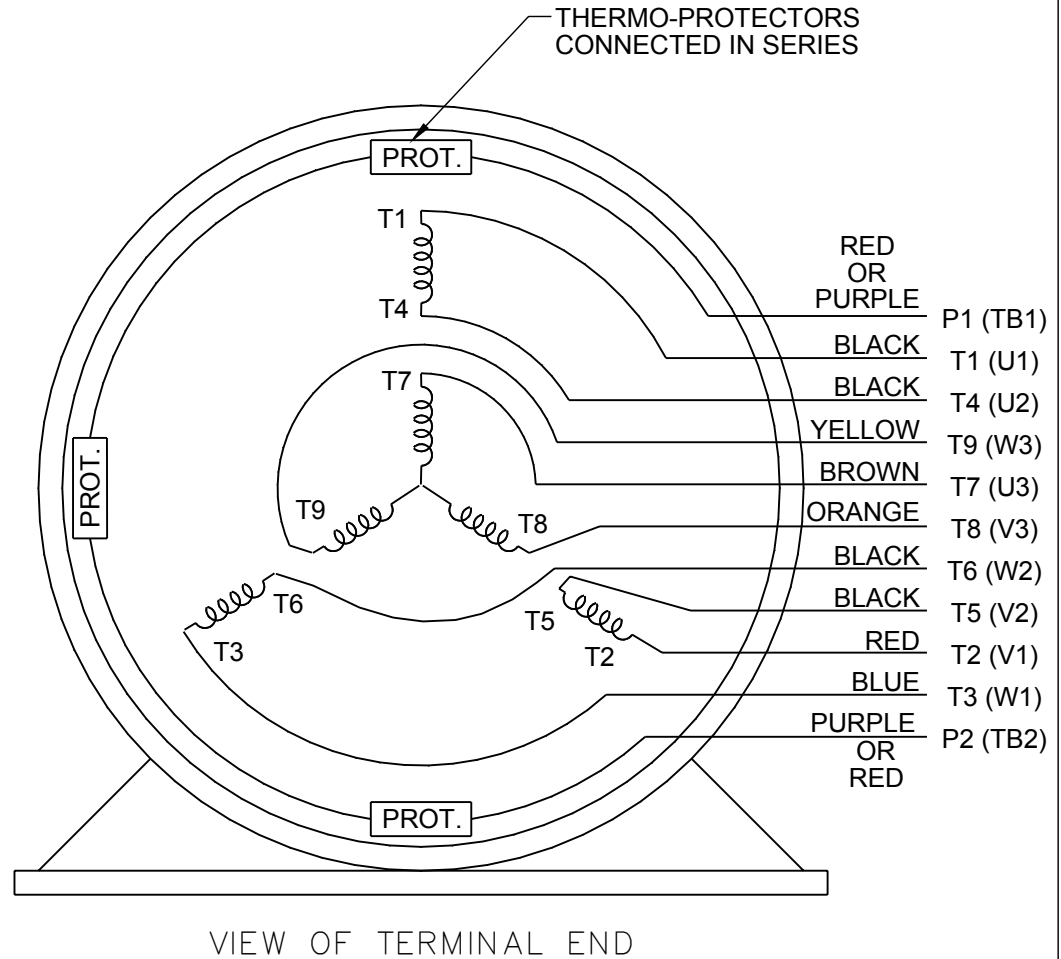

DRAWING REVISION R	REVISION BY AJW	DATE 07-17-2015		DRAWN BY SMC	Regal Beloit America, Inc.	
ECO ECO-0081632	APPROVED BY T. VUE	DATE 07-17-2015		DATE 05-13-1992		
ECO DESCRIPTION REV'D IEC NOTATIONS PER IEC 60034-8				APPROVED BY TB	DESCRIPTION CONN DIAGRAM-INTERNAL 3 PHASE - DUAL VOLTAGE MOTOR	
<small>COPYRIGHT REGAL BELOIT AMERICA, INC. ALL RIGHTS RESERVED. PROPRIETARY AND CONFIDENTIAL INFORMATION - THIS DOCUMENT IS THE PROPERTY OF REGAL BELOIT AMERICA, INC. ("OWNER") AND CONTAINS OWNER'S PROPRIETARY INFORMATION. ANY PERSON, CORPORATION OR OTHER FIRM RECEIVING IT IS DEEMED, BY RECEIVING IT, TO AGREE THAT IT, AND/OR ANY PART OF IT, SHALL NOT BE DISCLOSED TO ANY PERSON, CORPORATION OR OTHER ENTITY, DUPLICATED, AND/OR USED, EXCEPT AS EXPRESSLY APPROVED IN WRITING IN ADVANCE BY OWNER. THIS DOCUMENT SHALL BE RETURNED TO OWNER UPON REQUEST. IT MAY BE SUBJECT TO CERTAIN RESTRICTIONS UNDER APPLICABLE EXPORT CONTROL LAWS AND REGULATIONS.</small>				DATE 05-13-1992	MATERIAL	PROCESS/FINISH
			REFERENCE EE7308/EE7300	SIZE A	DRAWING NUMBER EE7308T	SHEET 1 OF 1
			THIRD ANGLE PROJECTION			

CERTIFICATION DATA SHEET

Model#: 286TTGN16546 AA WINDING#: K2864159 NONE 6
 CONN. DIAGRAM: A-EE7308T ASSEMBLY: F1 ONLY
 OUTLINE: B-SS311003-1425

TYPICAL MOTOR PERFORMANCE DATA

HP	KW	SYNC. RPM	F.L. RPM	FRAME	ENCLOSURE	KVA CODE	DESIGN
30&25	22.4&18.7	1800	1773&1475	286T	EPFC	G	B

PH	Hz	VOLTS	FL AMPS	START TYPE	DUTY	INSL	S.F	AMB°C	ELEVATION
3	60/50	230/460#190/380	73/36.5&74/37	LINE OR INVERTER	CONTINUOUS	F3	1.15/1.15	40	3300

FULL LOAD EFF: 94.1&93.6	3/4 LOAD EFF: 94.1	1/2 LOAD EFF: 93.6	GTD. EFF	ELEC. TYPE	NO LOAD AMPS
FULL LOAD PF: 82&81.5	3/4 LOAD PF: 77	1/2 LOAD PF: 67.5	93.6	SQ CAGE INV RATED	30 / 15

F.L. TORQUE	LOCKED ROTOR AMPS	L.R. TORQUE	B.D. TORQUE	F.L. RISE°C
89 LB-FT	434 / 217	165 LB-FT 185	245 LB-FT 275	60

SOUND PRESSURE @ 3 FT.	SOUND POWER	ROTOR WK^2	MAX. WK^2	SAFE STALL TIME	STARTS /HOUR	APPROX. MOTOR WGT
65 dBA	75 dBA	4.6 LB-FT^2	225 LB-FT^2	25 SEC.	2	540 LBS.

*** SUPPLEMENTAL INFORMATION ***

DE BRACKET TYPE	ODE BRACKET TYPE	MOUNT TYPE	ORIENTATION	SEVERE DUTY	HAZARDOUS LOCATION	DRIP COVER	SCREENS	PAINT
STANDARD	STANDARD	RIGID	HORIZONTAL	PREMIUM SEVERE DUTY	EXP PROOF CL I GR C&D CL II GR F&G T3B	FALSE	NONE	BLUE (EPOXY)

BEARINGS		GREASE	SHAFT TYPE	SPECIAL DE	SPECIAL ODE	SHAFT MATERIAL	FRAME MATERIAL
DE	OPE	POLYREX EM	T	NONE	NONE	1045 HOT ROLLED (C-204)	CAST IRON
BALL	BALL						
6311	6210						

THERMO-PROTECTORS				THERMISTORS	CONTROL	SPACE /n HEATERS
THERMOSTATS	PROTECTORS	WDG RTDs	BRG RTDs	NONE	FALSE	NONE VOLTS
TSTATS (N/C)	NOT	NONE	NONE			

If Inverter equals NONE, contact factory for further information

INVERTER TORQUE: CONSTANT 10:1 INV. HP SPEED RANGE: 1.5 X BASE SPEED
ENCODER: NONE NONE NONE NONE NONE PPR
BRAKE: NONE NONE NONE P/N NONE NONE NONE NONE FT-LB NONE V NONE Hz

*
N
O
T
E
S
*

** Subject to change without notice.