

2E-N SERIES - 1/40 HP

APPLICATIONS

Small submersible oil-filled pump with epoxy coated cast aluminum housing. For commercial, industrial and home applications including statuary fountains, water displays, air conditioners, machine tool coolants, and many other applications where liquid must be transferred or recirculated.

FEATURES

- Epoxy coated die-cast aluminum housing
- Oil-filled motor
- 11.8-foot maximum lift
- Screened inlet
- 1/4-inch MNPT discharge
- Thermal overload protection
- For submersible use only



2E-N



SERIES SPECIFICATIONS

Item No.	Model	Discharge	Listing	HP	Volts	Hz	Amps	Watts	Gallons per hour (Liter per hour) @ Height				Shut-Off	PSI	Cord	Weight lbs (Kg)
									1'	3'	5'	10'				
502103	2E-N	1/4" MNPT	UL	1/40	115	60	1.7	100	300 (1136)	255 (965)	205 (776)	70 (265)	11.8' (3.6 m)	5.1	6' (1.8 m)	4.67 (2.12 Kg)

SMALL SUBMERSIBLE PUMPS

2E-N SERIES - 1/40 HP

ENGINEERING DATA

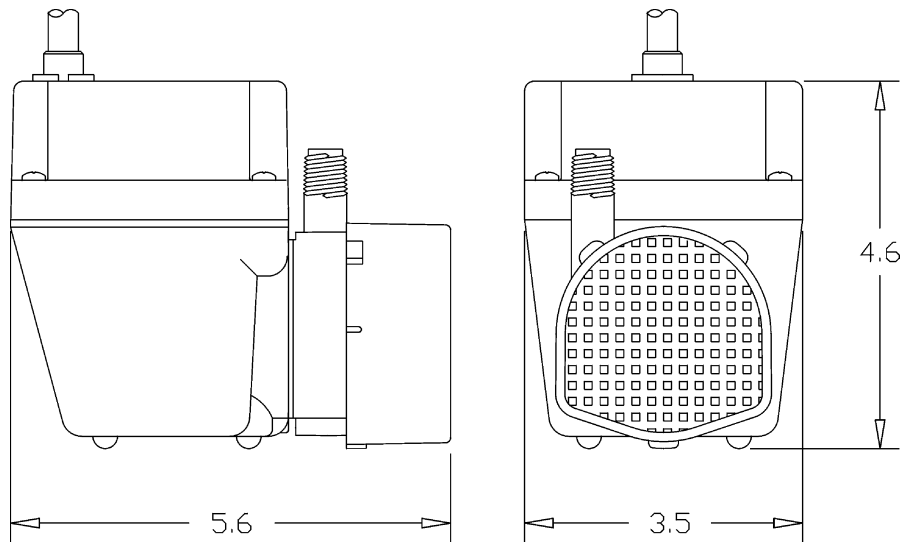

PERFORMANCE DATA

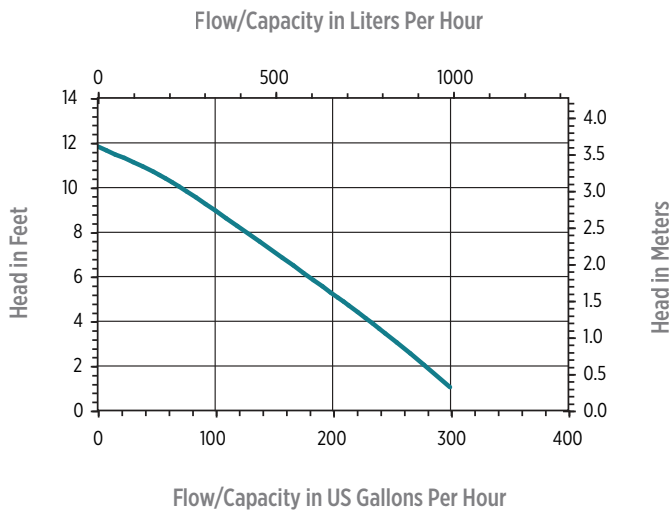

REPLACEMENT PARTS

Volute	102333
Impeller	102470
Screen	102909
Gasket	102601

