



INTELLIBOOST® R SERIES

WE'LL GIVE IT A BOOST AND MAINTAIN THAT PRESSURE

A true variable speed water pressure booster that provides constant pressure in an all-in-one unit



CITY BOOSTING



LIGHT IRRIGATION



LIGHT COMMERCIAL



DON'T BE FOOLED BY THE CURVE

Flat line the competition.

Pentair's Intelliboost® is the only TRUE variable speed booster with an LCD screen that gives you an easy to use, all-in-one solution for not only boosting, but delivering constant pressure throughout the system.

True constant pressure comes from true variable speed. Even when you use more water the unit holds pressure in a flat line. With a standard booster, more water usage means less pressure as indicated below.



Exclusive plain language LCD display

- Easy to read screen
- Easy to set pressure
- Shows current pressure
- Displays fault codes

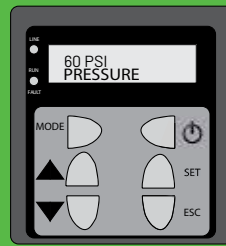

PERFORMANCE

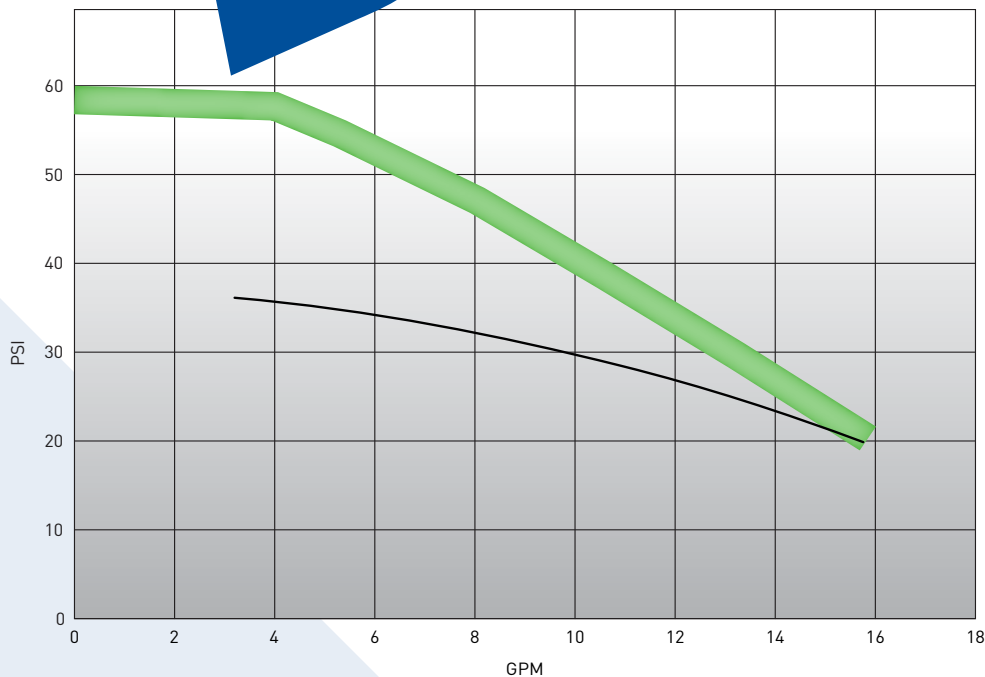

Boosts pressure up to 60 PSI

- Pentair Intelliboost
- Non-VFD booster

What's In It For You?

Give Your Customer What They Want

Serve your customers better by providing them with a product that maintains a consistent pressure when and where they need it.

Gets You In and Out Quickly

The Intelliboost is an all-in-one, completely assembled unit with smart controls, allowing you to install and set-up quickly, getting you to your next job faster.

Makes You More Competitive

With intelligent controls, the Intelliboost has built-in protections to avoid irregularities such as:

- Dry-run
- Overload Protection
- Over temperature
- Over pressurizing your system



PLUMB IT



WIRE IT

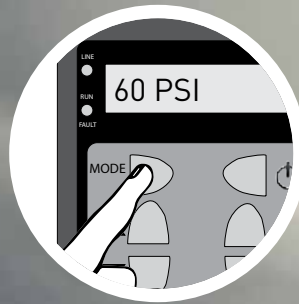

SET IT



GO!



Benefits Include:

- 1 Variable speed controller with easy-to-read LCD screen and easy-to-use keypad that allow you to set your exact pressure need
- 2 Efficient, smoother running three-phase motor that uses less power than competitive single-phase motors
- 3 Stainless steel pump body provides a durable, corrosion resistant pump
- 4 Pressure transducer measures changes in system pressure continuously
- 5 Pre-assembled 2 liter tank
- 6 Built-in check valve to prevent back flow that can damage pump and system

WARRANTY

Dependable Quality

With our standard 1 year warranty, we have you covered in case any issues arise. Pentair Pro Dealers are eligible for our extended warranty for a total of 3 years of coverage.

INTELLIBOOST® R SERIES MULTI-STAGE VARIABLE FREQUENCY DRIVE BOOSTING PUMP

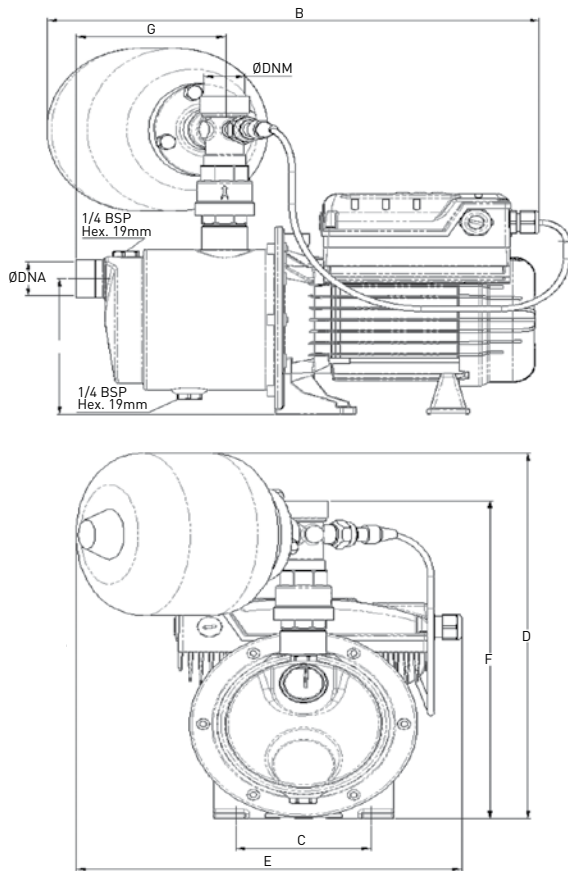

Dimensions (inch)

A	B	C	D	E	F	G
5.1	15.0	3.9	13.7	11.8	12.0	4.6

SPECIFICATIONS

Pump Case – Stainless steel

Diffuser – Reinforced polypropylene

Impeller – Reinforced polypropylene

Mechanical Shaft Seal – Carbon, ceramic, stainless steel

Mounting Base – Steel

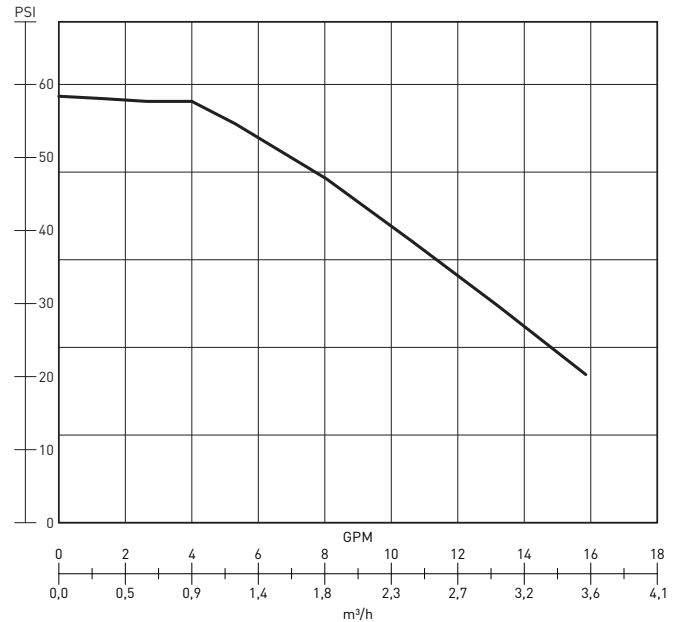

ORDERING INFORMATION

Catalog Number	HP	Suction	Discharge	Pump/Motor Unit	
				Length	Approx Wt. Lbs.
SINGLE PHASE – 230V					
MIB0715B/ MIB0715S*	3/4	1"	1"	20-7/8"	30

*MIB0715B for Berkeley®
MIB0715S for Sta-Rite®



293 Wright Street
Delavan, WI 53115
USA
Ph: 888.782.7483
Orders Fax: 800.426.9446

490 Pinebush Road
Unit 4
Cambridge, Ontario N1T 0A5
Canada
Ph: 800.363.7867
Orders Fax: 888.606.5484

www.Pentair.com

All Pentair trademarks and logos are owned by Pentair. All other brands or product names are trademarks or registered marks of their respective owners. Because we are continuously improving our products and services, Pentair reserves the right to change specifications without prior notice. Pentair is an equal opportunity employer.

P11786WS (11/28/18) ©2018 Pentair plc. All Rights Reserved.