

PRODUCT INFORMATION PACKET

marathon[®]
Motors

Model No: 405TSTDS4333
Catalog No: U533
125,1800,DP,405TS,3/60/200/400
Fire Pump



Regal and Marathon are trademarks of Regal Beloit Corporation or one of its affiliated companies.
©2018 Regal Beloit Corporation, All Rights Reserved. MC017097E

REGAL[®]



Nameplate Specifications

Output HP	125 Hp	Output KW	93.0 kW
Frequency	60 Hz	Voltage	200/400 V
Current	331.0/166.0 A	Speed	1778 rpm
Service Factor	1.15	Phase	3
Efficiency	94.5 %	Duty	Continuous
Insulation Class	B	Design Code	B
KVA Code	G	Frame	405TS
Enclosure	Drip Proof	Overload Protector	No
Ambient Temperature	50 °C	Drive End Bearing Size	6313
Opp Drive End Bearing Size	6313	UL	No
CSA	Y	CE	Y
IP Code	12		

Technical Specifications

Electrical Type	Squirrel Cage Induction Run	Starting Method	Wye Start Delta Run
Poles	4	Rotation	Reversible
Mounting	Rigid base	Motor Orientation	Horizontal
Drive End Bearing	Ball	Opp Drive End Bearing	Ball
Frame Material	Cast Iron	Shaft Type	TS
Overall Length	31.06 in	Frame Length	17.00 in
Shaft Diameter	2.125 in	Shaft Extension	4.5 in
Assembly/Box Mounting	F1/F2 Capable		
Outline Drawing	B-SS509257-1700	Connection Diagram	A-EE7308AA

This is an uncontrolled document once printed or downloaded and is subject to change without notice. Date Created: 06/29/2018

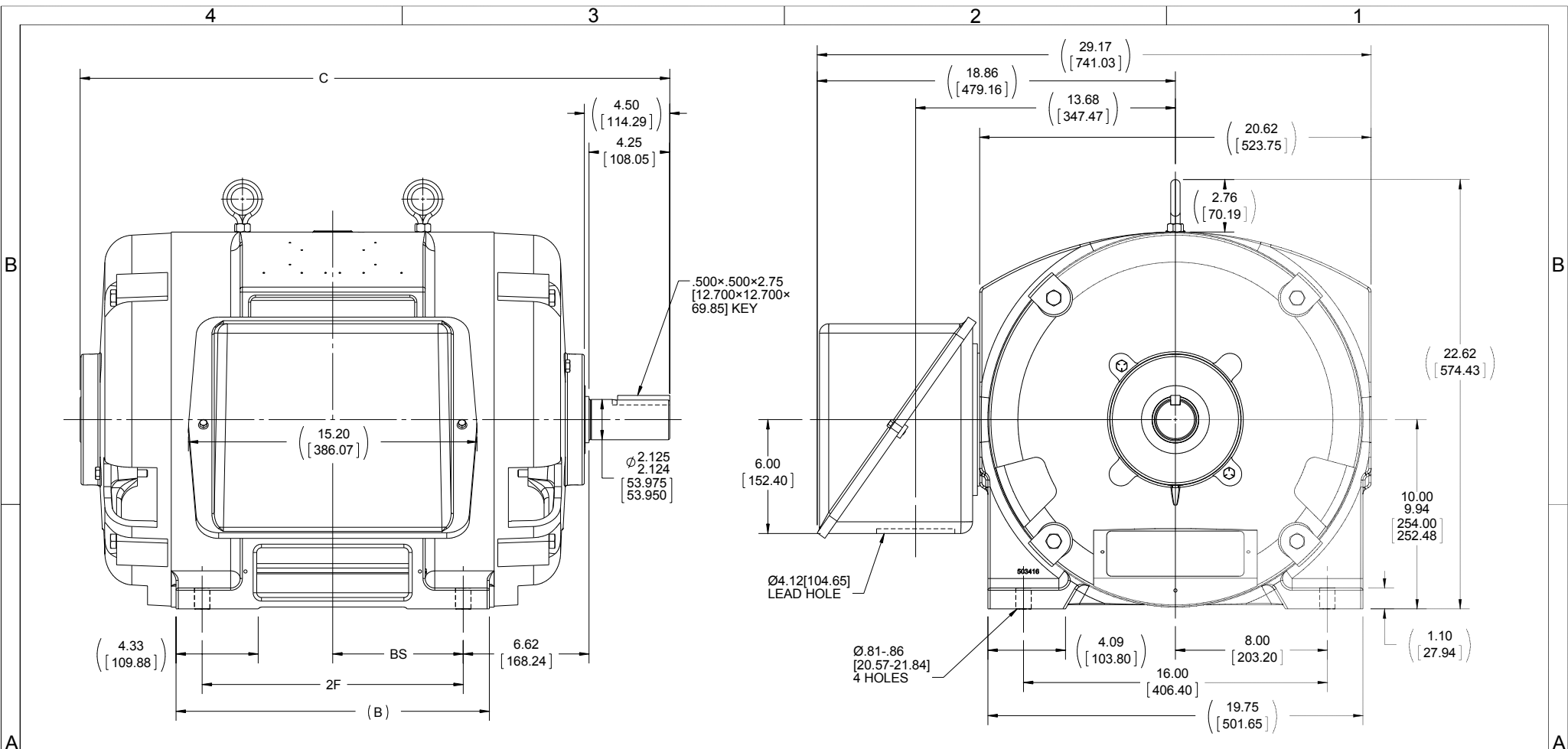

NOTE:
 1. CONDUIT BOX CAN BE ROTATED IN 90° STEPS.
 2. BOX CAN BE MOUNTED ON OPPOSITE SIDE BY REMOVING BRACKETS AND TURNING FRAME 180°
 3. NAMEPLATES TO BE READ FROM CONDUIT BOX SIDE OF THE MOTOR

DASH	FRAME	B	C	2F	BS
1550	404TS	15.00 [381.00]	29.56 [750.82]	12.25 [311.15]	6.12 [155.45]
1700	405TS	16.50 [419.10]	31.06 [788.92]	13.75 [349.25]	6.88 [174.75]

DRAWING REVISION K	REVISION BY AJW	DATE 09-28-2015
ECO ECO-0085893	APPROVED BY JHA	DATE 09-28-2015
ECO DESCRIPTION UPDATED TO CURRENT STANDARDS		
<small>COPYRIGHT REGAL BELOIT AMERICA, INC. ALL RIGHTS RESERVED. PROPRIETARY AND CONFIDENTIAL INFORMATION - THIS DOCUMENT IS THE PROPERTY OF REGAL BELOIT AMERICA, INC. ("OWNER") AND CONTAINS OWNER'S PROPRIETARY INFORMATION. ANY PERSON, CORPORATION OR OTHER FIRM RECEIVING IT IS DEEMED, BY RECEIVING IT, TO AGREE THAT IT, AND/OR ANY PART OF IT, SHALL NOT BE DISCLOSED TO ANY PERSON, CORPORATION OR OTHER ENTITY, DUPLICATED, AND/OR USED, EXCEPT AS EXPRESSLY APPROVED IN WRITING IN ADVANCE BY OWNER. THIS DOCUMENT SHALL BE RETURNED TO OWNER UPON REQUEST. IT MAY BE SUBJECT TO CERTAIN RESTRICTIONS UNDER APPLICABLE EXPORT CONTROL LAWS AND REGULATIONS.</small>		

TOLERANCES UNLESS OTHERWISE SPECIFIED:		
DEC.	INCH	mm
-X	+0.1	[+2.5]
.XX	+0.02	[+0.51]
.XXX	+0.005	[+0.127]
.XXXX	+0.0005	[+0.0127]
REMOVE BURRS & BREAK SHARP EDGES: .003/.015 [076/381] X 45° CORNER FILLETS: R.02 [51] MACHINED SURFACES: 200 INCH 5.1 mm SHOWN IN [BRACKETS]		

DRAWN BY TLB
DATE 02-24-1988
APPROVED BY ML
DATE 02-24-1988
REFERENCE
THIRD ANGLE PROJECTION

REGAL™ Regal Beloit America, Inc.

OUTLINE
400TS FR.-DR.PR.-(STD)

MATERIAL: _____ PROCESS/FINISH: _____

SIZE: B DRAWING NUMBER: **SS509257** SHEET: 1 OF 1



LOW VOLTAGE



HIGH VOLTAGE



DRAWING REVISION K	REVISION BY AJW	DATE 07-17-2015
ECO ECO-0081632	APPROVED BY T. VUE	DATE 07-17-2015
ECO DESCRIPTION REV'D IEC MARKINGS PER IEC 60034-8		
COPYRIGHT REGAL BELOIT AMERICA, INC. ALL RIGHTS RESERVED. PROPRIETARY AND CONFIDENTIAL INFORMATION - THIS DOCUMENT IS THE PROPERTY OF REGAL BELOIT AMERICA, INC. ("OWNER") AND CONTAINS OWNER'S PROPRIETARY INFORMATION. ANY PERSON, CORPORATION OR OTHER FIRM RECEIVING IT IS DEEMED, BY RECEIVING IT, TO AGREE THAT IT, AND/OR ANY PART OF IT, SHALL NOT BE DISCLOSED TO ANY PERSON, CORPORATION OR OTHER ENTITY, DUPLICATED, AND/OR USED, EXCEPT AS EXPRESSLY APPROVED IN WRITING IN ADVANCE BY OWNER. THIS DOCUMENT SHALL BE RETURNED TO OWNER UPON REQUEST. IT MAY BE SUBJECT TO CERTAIN RESTRICTIONS UNDER APPLICABLE EXPORT CONTROL LAWS AND REGULATIONS.		



DRAWN BY LZ	Regal Beloit America, Inc.	
DATE 01-12-1994		
APPROVED BY GK	DESCRIPTION CONN DIAGRAM-EXTERNAL 3Ø-2/1 DELTA-12 LEADS	
DATE 01-14-1994		
REFERENCE	MATERIAL	PROCESS/FINISH
THIRD ANGLE PROJECTION	SIZE A	DRAWING NUMBER EE7308AA
		SHEET 1 OF 1

