

HIGH TEMPERATURE
Low Profile Commercial Grade
Condensate Pump
PlenumPlus™ Model KL-1DG

DATA SHEET



- ◆ UL 2043 Tested
- ◆ Plenum Rated
- ◆ Rated for use up to 212°
- ◆ 1 quart reservoir, low profile height of 1-3/4"

The same great features as our larger Plenum Plus™ commercial grade condensate pumps, but now in a robust low profile model for applications where space is restricted.

Hartell's PlenumPlus™ Low Profile Commercial Grade Condensate Pump KL-1DG has been tested to, and yielded results that fell within the acceptable criteria of UL standard 2043, Third Edition, "Fire test for heat and visible smoke release for discrete products and their accessories installed in air-handling spaces." The UL standard 2043 rating assures the PlenumPlus pump is an optimal choice for use in plenum spaces.

FEATURES:

- ◆ Two inlet sizes 1" and 1-3/4"
- ◆ Auxiliary safety switch
- ◆ 18ft maximum lift
- ◆ Built in check valve
- ◆ 1 year warranty

**PLENUM
 RATED**

**1
 YEAR
 WARRANTY**



Model	Part No.	Voltage	Lift / Feet	6'	12'	18'	Max Lift	Dimensions			
								Width	Length	Height	Weight
KL-1DG-115	801030	115	Gallons / hr	55	38	---	18'	5.5"	10"	4.75"	5lb
KL-1DG-230	801049	230	Lift / Meters	1.83m	3.66m	5.49					
KL-1DG-277	801053	277	Liters / hr	208.2	143.85	---					

When safety counts, you can rely on Hartell PlenumPlus™

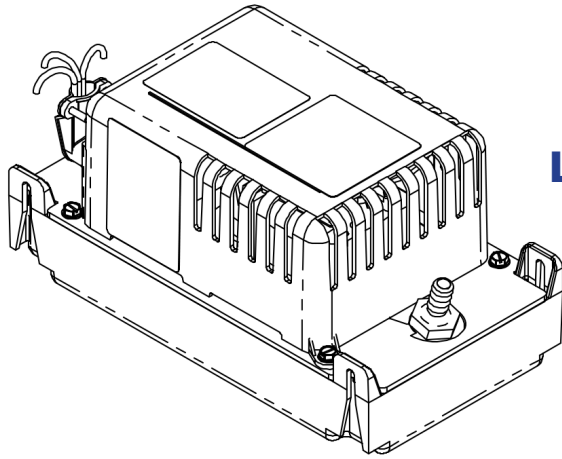

DATA SHEET

HIGH TEMPERATURE Low Profile Commercial Grade Condensate Pump PlenumPlus™ Model KL-1DG

**PLENUM
RATED**

