

Liberty Pumps®

Pro680-Series



US Patent #s
7,520,736, 7,563,082,
7,159,806 & 8,523,532



Includes duplex pump controller and alarm with plug-in ready cords for quick, easy installation!

Indoor and outdoor models available.

Duplex Pump System

2" Discharge

Compact duplex system - designed for residential and light commercial sewage applications.

Perfect for basement bathroom additions and remodeling projects.

Available in 115V or 230V.

Fully assembled from factory.

Features:

- Robust system features a compact heavy-duty polyethylene basin and cover
- Solids-handling and ProVore grinder models available
 - 46 Gallon capacity
- System can be installed above or below floor level
 - Two pumps provide secure uninterrupted service
- Easy access cover with QuickTree® technology – allows for quick float removal and servicing
- Heavy-duty integrated rubber gaskets on covers
- Secure 16 bolt cover standard on all models. Passes 10' stack test

innovate. evolve.

Pro680

QuickTree® Technology

Features:

- QuickTree® technology allows easy access and removal of switches without disturbing pump or plumbing.
- Integrated rubber seals permanently attached to cover.
- Unique cord seal technology integrated into the inspection cover.
- Shallow basin design (24") for easier installation in difficult soil/bedrock locations.
- Large 46 gallon capacity for longer pump cycles.
- Integrally molded torque stops secure the pump in its proper position.
- Integrally molded anti-flotation collar.
- Durable polyethylene construction.
- Completely assembled.

Performance Curve 60 Hz.

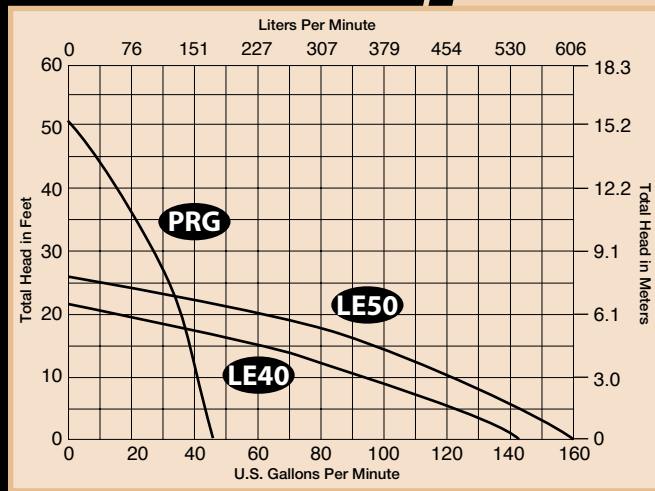

QuickTree® Technology

Integral Rubber Seals

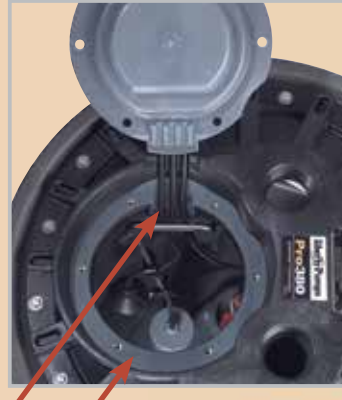

Unique integrated cord seal technology and permanent rubber cover gaskets.



Floats are easy-to-service with QuickTree® Technology



24"

US Patent #s
7,520,736, 7,563,082,
7,159,806 & 8,523,532

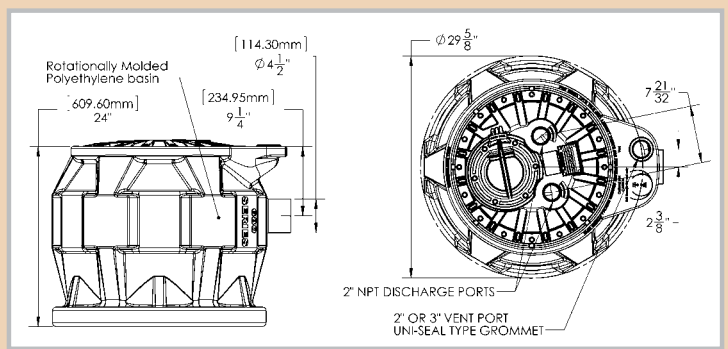

Pro680-Series

Compact Duplex System



Models:

| MODEL | HP | VOLTS | PHASE | AMPS | DISCHARGE | CORD LENGTH | CONTROLLER | WGT. LBS. |
|---|------|-------|-------|------|-----------|-------------|------------|-----------|
| <i>ProVore Grinder Models</i> | | | | | | | | |
| P682XPRG101 | 1 | 115 | 1 | 12 | 2" | 10' | Indoor | 151 |
| P682XPRG101W | 1 | 115 | 1 | 12 | 2" | 10' | Outdoor | 152 |
| P682XPRG102 | 1 | 230 | 1 | 6 | 2" | 10' | Indoor | 151 |
| P682XPRG102W | 1 | 230 | 1 | 6 | 2" | 10' | Outdoor | 152 |
| <i>LE-Series Solids-handling Models</i> | | | | | | | | |
| P682XLE41 | 4/10 | 115 | 1 | 12 | 2" | 10' | Indoor | 113 |
| P682XLE41W | 4/10 | 115 | 1 | 12 | 2" | 10' | Outdoor | 112 |
| P682XLE51 | 1/2 | 115 | 1 | 12 | 2" | 10' | Indoor | 120 |
| P682XLE51W | 1/2 | 115 | 1 | 12 | 2" | 10' | Outdoor | 119 |
| P682XLE52 | 1/2 | 230 | 1 | 6 | 2" | 10' | Indoor | 121 |
| P682XLE52W | 1/2 | 230 | 1 | 6 | 2" | 10' | Outdoor | 120 |

IAPMO Listed Basin

The Pro680 Basin is specifically designed to pass a 10' stack test and is IAPMO listed.



See PRG-Series or LE40/LE50-Series literature for complete pump performance and specifications data. For 25' pump and float cords, add "-2" suffix to model number. Example: P682XPRG101-2

Optional Basin Extension

X8-D

8" Basin Extension

Sealed basin extension increases Pro-Series height by 8", allowing longer pitched pipe runs to the inlet connection.

Model X8-D extension includes gasket, stainless steel bolts, longer QuickTree® for float mounting and discharge pipe extension.

To order X8-D extension factory assembled to any ProVore®-Series system, add "X8D" to model number

Examples: P682X8DXPRG101



PDC Duplex Control



Indoor model shown

- Automatically alternates pump operation – equalizing wear and extending pump life
- Plug-in ready wiring for easy and quick installation (indoor model only)
- QuickTree® mounted floats with quick-disconnect at box (indoor model only)
- Green power indicator
- Green pump run indicators
- Audible and visual alarm
- 9 volt back-up for alarm
- Receptacles are angled to accept standard or right-angled plugs
- Programmed automatic 6 hour run limiter protects against run-dry pump conditions
- NEMA 1 indoor or NEMA 4X outdoor options available

Voltage: 115 or 230 depending on system ordered (60 hz.)

| PDC MODEL | VOLTS | PHASE | Hz. | CORD LENGTH | INDOOR/ OUTDOOR | SYSTEM |
|-----------|-------|-------|-----|-------------|-----------------|--------------|
| PDC-115 | 115 | 1 | 60 | 10' | Indoor | P682XPRG101 |
| PDCW-115 | 115 | 1 | 60 | 10' | Outdoor | P682XPRG101W |
| PDC-230 | 230 | 1 | 60 | 10' | Indoor | P682XPRG102 |
| PDCW-230 | 230 | 1 | 60 | 10' | Outdoor | P682XPRG102W |

Pro680 duplex systems are shipped complete with the PDC control unit. Floats are pre-set at proper levels in the system. See PDC literature sheet for complete control specifications.

For 25' float cord, add "-2" suffix to model number. Example: PDC-115-2



**Liberty Pumps • 7000 Apple Tree Avenue • Bergen, New York 14416
Phone 800-543-2550 Fax (585) 494-1839**

WWW.
libertypumps
.com

Specifications are subject to change without notice. Copyright © Liberty Pumps, Inc. 2016 All rights reserved. LLIT6712-R06/16