



*an Accudyne Industries brand*



# **PLENUMPLUS™**

## **Commercial Grade Condensate Removal Pumps**

**(KL-1DG-115, KL-1DG-230 and KL-1DG-277)**

### **IOM Manual**

Manual No. : 52200

Rev. : B

Rev. Date : 05/2015



*an Accudyne Industries brand*



## WARRANTY

HARTELL KL-1DG-115, KL-1DG-230 and KL-1DG-277 series condensate pump is guaranteed to be free from defects in workmanship or materials and to function satisfactorily, when properly installed. See our website for additional warranty information at [www.hartell.com](http://www.hartell.com).

This guarantee does not apply if the product has been misapplied or mechanically damaged, HARTELL assumes no liability for resultant damages of any kind arising out of the use of its products.

**THIS PAGE INTENTIONALLY LEFT BLANK**



## TABLE OF CONTENTS

<b>SECTION 1 - INTRODUCTION</b> .....	<b>1</b>
<b>SECTION 2 - INSTALLATION AND OPERATION</b> .....	<b>2</b>
2.1 INSTALLATION .....	2
2.1.1 Piping .....	2
2.1.2 Electrical Connections .....	3
2.1.3 Line Voltage .....	3
2.1.4 Low Voltage-Auxiliary Safety Switch .....	3
2.2 OPERATION .....	3
<b>SECTION 3 - MAINTENANCE</b> .....	<b>4</b>
3.1 PUMP DOES NOT RUN .....	4
3.2 PUMP MOTOR RUNS WITH NO DISCHARGE .....	4

**THIS PAGE INTENTIONALLY LEFT BLANK**

HARTELL condensate pumps are designed to collect and automatically remove the water produced from an air conditioner evaporative coil and/or a gas-condensing furnace. This pump has been carefully engineered to provide long, trouble free service and is of the highest quality workmanship and materials.

These pumps have been thoroughly inspected and tested, then carefully packaged to insure safe delivery and operation. When you receive your pump, examine it carefully to determine that there are no damaged or broken parts. If damage is detected, notify the firm from where the pump was purchased. They will assist with a repair or replacement.

See the precautions listed below before continuing.

**⚠ CAUTION** READ ALL INSTRUCTIONS CAREFULLY BEFORE STARTING INSTALLATION.

- 1 Pump should only be used with liquids compatible with pump component materials. Do not use to pump flammable or explosive fluids. Do not use in explosive atmospheres.
- 2 The pump is supplied with Pigtails to hard wire the pump. To reduce the risk of electrical shock be certain that it is connected to a ground wire.
- 3 In any installation where property damage and/or personal injury might result from an inoperative or leaking pump due to power outages, discharge line blockage, or any other reason, a back up system(s) (aux. switch) and/or alarm should be used.
- 4 Do not handle pump with wet hands or when standing on a wet or damp surface, or in water.
- 5 Shut off the electrical power at the fuse box before making any connections. All wiring must comply with local codes.

## SECTION 2 - INSTALLATION AND OPERATION

### 2.1 INSTALLATION

Carefully unpack the pump and select a mounting location in the Plenum area (see *Figure 1*). The pump must be level and the inlet must be below the lowest drain, either coil or furnace. If wall or case mounting, use the mounting tabs on either side of the reservoir to secure the pump.

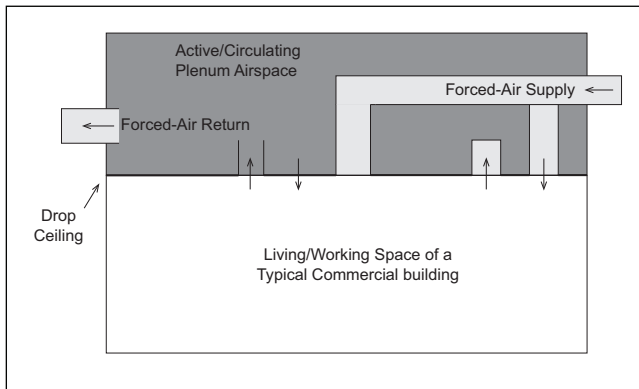

Figure 1

#### 2.1.1 Piping

Run flexible tubing or pipe from the evaporator and furnace to the pump. Connect to either inlet barbed fitting. Make sure the pipe does not interfere with the float. If barbed fitting is not used, cut an angle on the inlet pipe so that it doesn't close off against the bottom of the pump.

Connect tubing to the check valve. Extend this tubing straight up as high as necessary. (Do not extend this tubing past the head/GPH of the pump installed). Do not kink the tubing, as this will block the flow. From this high point, slope the discharge tubing downward to a point above the drain, then turn down and extend to a point below or level with the bottom of the condensate pump. If it is not possible to slope the discharge tubing downwards, make an inverted "U" trap directly above the pump at the highest point (*Figure 2*).

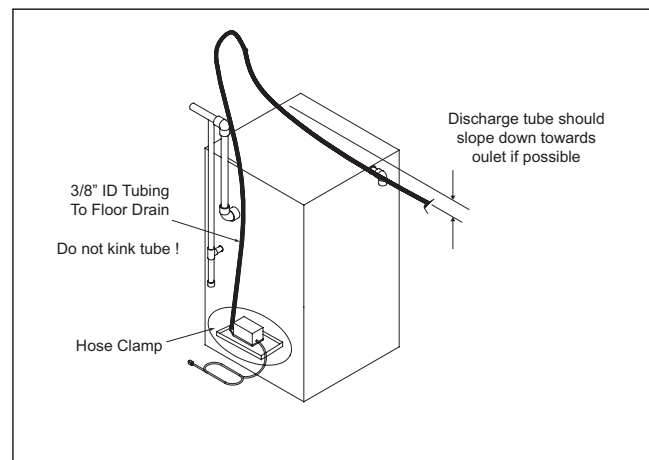

Figure 2



## SECTION 2 - INSTALLATION AND OPERATION

### 2.1.2 Electrical Connections

**NOTE:**

*Review precautions in Section 1.*

### 2.1.3 Line Voltage

Hard wire red lead and white lead to a Power Source to the proper voltage as indicated on the motor nameplate. Connect only to a source of constant power, not an intermittent source such as a fan or limit control circuit.

### 2.1.4 Low Voltage-Auxiliary Safety Switch

Connect the leads of auxiliary safety switch to the thermostat control circuit of the air conditioner/furnace. This will disrupt the thermostat demand in a high water condition (*Figure 3*).

### 2.2 OPERATION

After proper installation, the operation of the HARTELL condensate pump is automatic. Water is collected in the reservoir and pumped out when the float raises to a pre-set point. As the water level goes down the float turns off the motor at another pre-set point. Under most circumstances the pump requires little maintenance for efficient operation. If a problem occurs, please refer to the maintenance instructions below.

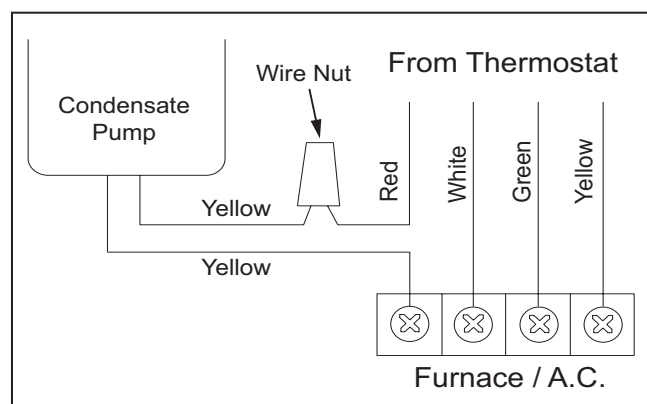

**Figure 3**

**CAUTION** THERMOSTAT DEMAND DISRUPTION SHOULD NOT BE UTILIZED IF COOLING OR HEATING REQUIREMENTS ARE A NECESSITY. AN ALARM SYSTEM SHOULD BE USED WITH THE AUXILIARY SWITCH INSTEAD.

---

## SECTION 3 - MAINTENANCE

---

Visually inspect this pump seasonally to ensure there is no buildup of any kind inside the unit. If any problems develop, or a buildup is seen during visual inspection, the following guidelines can help to return the pump to service.

### 3.1 PUMP DOES NOT RUN

- 1 Check to see that the power to the system (air conditioner and/or furnace) is on to allow production of condensate.
- 2 Check that the pump is plugged in and the circuit is active (i.e. fuse or breaker not blown).
- 3 Check the level of water in the reservoir; the level must be within ½" of the reservoir top to activate the switch. (The inlet tube may be blocked and require cleaning if no water is entering the reservoir).
- 4 If there is a proper amount of water in the reservoir, the float may be stuck due to dirt or algae formation. (Flush the reservoir with warm water and a mild soap or detergent). See note from point 3.2.

### 3.2 PUMP MOTOR RUNS WITH NO DISCHARGE

- 1 Inspect the discharge tubing for its full length to make sure it is clear; make sure the tubing end is not plugged.
- 2 Make sure the check valve is not clogged. (If clogged, UNPLUG THE PUMP, remove the fitting and clean with mild soap or detergent). See note below.
- 3 The discharge port of the impeller chamber may be clogged due to an accumulation of debris.

**NOTE:**

*In case of extreme algae formation, UNPLUG THE PUMP, and fill the reservoir with a commercially available algaecide. Follow directions for destroying the algae. After the proper waiting period DUMP the algaecide out of the reservoir. Rinse with water, repeat if necessary. Be careful not to clog the check valve when starting the pump after this thorough cleaning.*

Keep these instructions with the pump. They may be valuable if service is needed under the terms of the warranty.

Model # \_\_\_\_\_

Date Code: \_\_\_\_\_

Date of Installation: \_\_\_\_\_

Dealer: \_\_\_\_\_

Installer: \_\_\_\_\_



*We are a proud member of Accudyne Industries, a leading global provider of precision-engineered, process-critical, and technologically advanced flow control systems and industrial compressors. Delivering consistently high levels of performance, we enable customers in the most important industries and harshest environments around the world to accomplish their missions.*



[info@hartell.com](mailto:info@hartell.com)  
[www.hartell.com](http://www.hartell.com)



HARTELL® is a registered trademark of Milton Roy, LLC.  
© 2015 Milton Roy, LLC.