

16G SERIES - 1 HP

APPLICATIONS

Offered in 115V and 230V options, the 16G Series is designed as a new or replacement grinder pump for the toughest residential and light commercial wastewater applications. Ideal for use as a drop-in replacement for any effluent or sewage pump struggling with clogs and binding.

FEATURES

1. Heavy-duty 1 hp Class F motor provides optimal power to prevent flushables and other debris from causing clogs and downtime.
2. Superior grinding capability with proven results based on the patented cutting mechanism renowned in Franklin Electric's 2 hp grinder pump. 27 stationary blades and eight rotating blades produce 3450 rpm and 745,200 cuts per minute.
3. 1-1/4" discharge and 2" NPT adapter discharge preassembled onto the pump.
4. Silicon carbide mechanical seal provides up to six times longer seal life with lower thermal expansion and higher abrasion resistance when compared to carbon ceramic seals.
5. Easily replaceable, 20' power cord is sealed at the connection point for unit protection against water.
6. Non-skid adjustable legs for stability.
7. Vertical and tethered float switch available on 115V and 230V models.

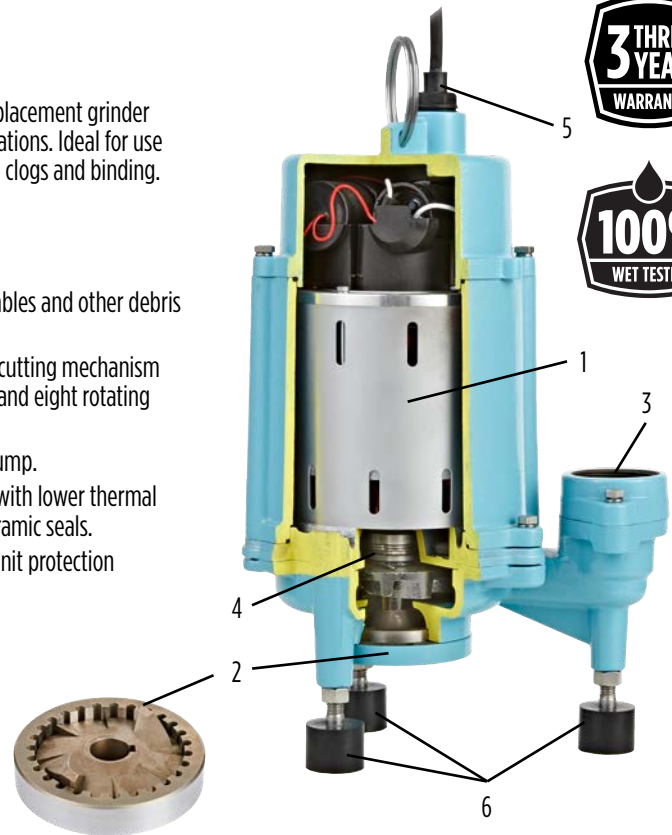

SERIES SPECIFICATIONS

Performance (GPM @ Height in Feet)					Shut-Off (ft)	PSI
10'	20'	30'	40'	50'		
49.3	43.9	37.5	28.7	15.3	53	22.9

Item No.	Model No.	HP	Voltage	Hz	Phase	Amps		Cord	Switch Type / Operation	Discharge	Weight (lbs)
						FLA	Start				
509809	16G-M151-20	1.0	115	60	1	12.5	65	20'	Manual	1-1/4" or 2"	76
509810	16G-F151-20	1.0	115	60	1	12.5	65	20'	Piggyback Tethered Float	1-1/4" or 2"	78
509811	16G-V151-20	1.0	115	60	1	12.5	65	20'	Piggyback Vertical Float	1-1/4" or 2"	78
509812	16G-M231-20	1.0	230	60	1	6.5	32.5	20'	Manual	1-1/4" or 2"	76
509813	16G-F231-20	1.0	230	60	1	6.5	32.5	20'	Piggyback Tethered Float	1-1/4" or 2"	78
509814	16G-V231-20	1.0	230	60	1	6.5	32.5	20'	Piggyback Vertical Float	1-1/4" or 2"	78

Packaged Systems Options

Item No.	Model No.	Vent	Discharge	Switch Type	Alarm	HP	Pump Item No.	Pump Model No.	Pump Voltage
509815	16JF2V2D	2"	2"	Piggyback Tethered Float	-	1	509809	16G-M151-20	115
509816	16SF2V2D	2"	2"	Piggyback Tethered Float	-	1	509809	16G-M151-20	115
509817	WCR-16GP	2"	2"	Piggyback Tethered Float	-	1	509810	16G-F151-20	115
509818	16G-DPLX	2"	2"	Stripped Lead Tethered Floats	-	1	509809	16G-M151-20	115

Note: Check valve not included.

SWITCH OPTIONS



Manual

Tethered

Vertical

PACKAGE OPTIONS



Pit+Plus Jr.
(16JF2V2D)

Pit+Plus Sr.
(16SF2V2D)

WCR System

Duplex System

GRINDER PUMPS

16G SERIES - 1 HP

ENGINEERING DATA

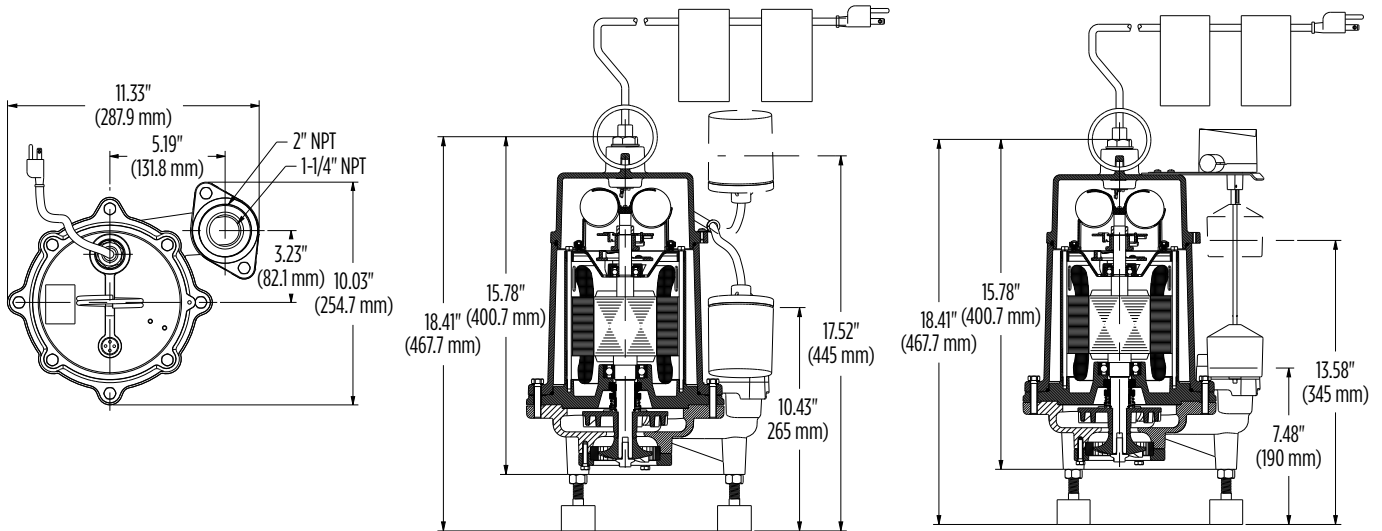

PERFORMANCE DATA

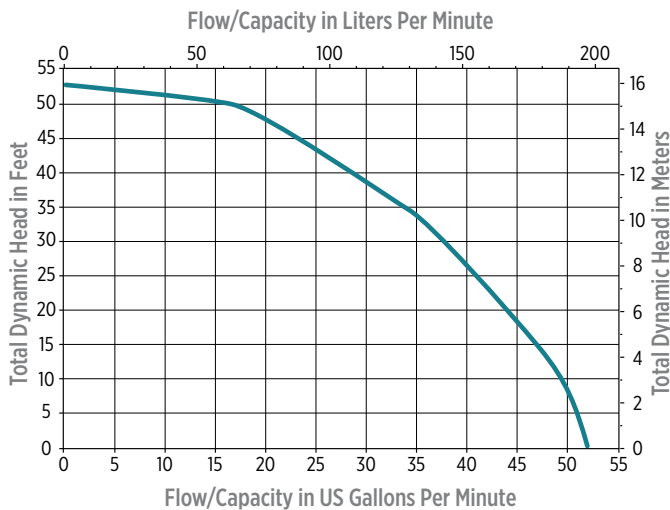

CONSTRUCTION

Cover, Housing, Volute, Impeller	Cast Iron
O-rings	NBR
Motor Design	Capacitor start, capacitor run
Power Cord	SJOOW
Insulation Class	F
Overload Protection	Internal, on-winding
Motor Shaft	420 stainless steel
Hardware	Stainless steel
Mechanical Seal	Silicon carbide and silicon carbide
Cutting Mechanism	440 stainless steel (56-60 Rockwell)

