

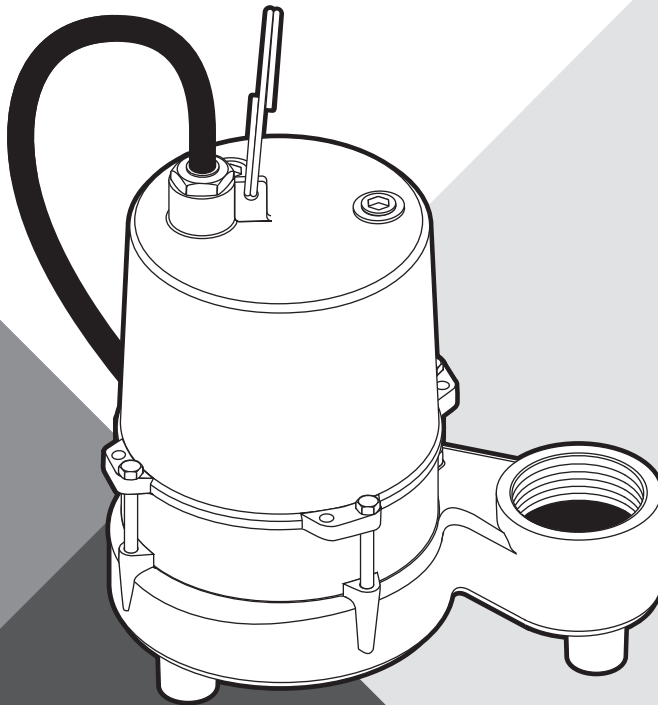

SUBMERSIBLE EFFLUENT PUMPS

ME45MC-11 • ME45AC-11 • ME45MC-21 • ME45AC-21



5937 0109

INSTALLATION AND OPERATION MANUAL

pentair.com

TABLE OF CONTENTS

SECTION.....	PAGE
Safety Information	3
General Information.....	4
Installation.....	5
Operation & Maintenance	6-7
Parts List.....	8
Troubleshooting	9
Warranty.....	10

SAFETY INFORMATION

SAFETY SYMBOLS

 This is the safety alert symbol. When you see this symbol on your pump or in this manual, look for one of the following signal words and be alert to the potential for personal injury:

 **DANGER** warns about hazards that will cause serious personal injury, death or major property damage if ignored.

 **WARNING** warns about hazards that can cause serious personal injury, death or major property damage if ignored.

 **CAUTION** warns about hazards that will or can cause minor personal injury or property damage if ignored.

The word **NOTICE** indicates special instructions that are important but not related to hazards.

GENERAL SAFETY

- ♦ Carefully read and follow all safety instructions in this manual and on the unit itself.
- ♦ Follow all applicable local and state codes and regulations.
- ♦ Keep safety labels in good condition, replacing any missing or damaged labels.
- ♦ Vent sewage or septic tank according to local codes.
- ♦ Do not install pump in any location classified as hazardous by National Electrical Code, ANSI/NFPA 80-1984 or the Canadian Electrical Code.

 **WARNING HAZARDOUS VOLTAGE. CAN SHOCK, BURN, OR KILL.**

During operation the pump is in water. To avoid fatal shocks, proceed as follows if pump needs servicing:

- ♦ Do not smoke or use devices that can generate sparks in a septic (gaseous) environment.
- ♦ Disconnect power to outlet box before unplugging pump.
- ♦ Take extreme care when changing fuses. Do not stand in water or put your finger in the fuse socket.
- ♦ Do not modify the cord or plug. When using cord and plug, use a grounded outlet only. When wiring to a system control, connect ground lead to the system ground.
- ♦ Be sure that construction and access to septic sumps conform with all OSHA requirements.
- ♦ Do not run the pump dry. Dry running can overheat the pump, (causing burns to anyone handling it) and will void the warranty.
- ♦ The pump normally runs hot. To avoid burns when servicing pump, allow it to cool for 20 minutes after shutdown before handling it.
- ♦ The pump is permanently lubricated. No oiling or greasing is required in normal operation. For overhaul, see instructions under this manual's Maintenance section.

CALIFORNIA PROPOSITION 65 WARNING:

 **WARNING** This product and related accessories contain chemicals known to the State of California to cause cancer, birth defects or other reproductive harm.

ELECTRICAL SAFETY

 **DANGER HAZARDOUS VOLTAGE. CAN SHOCK, BURN, OR KILL.**

When installing, operating, or servicing this pump, follow the safety instructions listed below.

- ♦ **DO NOT** splice the electrical power cord.
- ♦ **DO NOT** allow the plug on the end of the electrical cord to be submerged.
- ♦ **DO NOT** use extension cords. They are a fire hazard and can reduce voltage sufficiently to prevent pumping and/or damage motor.
- ♦ **DO NOT** handle or service the pump while it is connected to the power supply.
- ♦ **DO NOT** remove the grounding prong from the plug or modify the plug. To protect against electrical shock, the power cord is a three-wire conductor and includes a 3-prong grounded plug. Plug the pump into a 3-wire, grounded, grounding-type receptacle. Connect the pump according to the NEC or CEC and local codes.
- ♦ **BE SURE** that power supply information (Voltage/ Hertz/ Phase) on pump motor nameplate matches incoming power supply exactly. Install pump according to all electrical codes that apply.

GENERAL INFORMATION

OVERVIEW

This submersible effluent pump is designed for effluent and wastewater removal, sump drainage, dewatering and flood control.

Units have built in thermal overload protection with automatic reset. The mechanical seal and ball bearings on the motor shaft are permanently lubricated. Stainless steel hardware and a heavy duty lift out handle allow for easy disassembly after extended use.

NOTICE: This unit is not designed for applications involving salt water or brine. Use with salt water or brine will void warranty.

SPECIFICATIONS

- ◆ Power supply required: See Motor & Cord Table below
- ◆ Motor Duty: Continuous
- ◆ Discharge Adapter: 2" NPT

MOTOR & CORD SPECIFICATIONS

MODEL #	MOTOR HP	PHASE	VOLTS	CORD LENGTH	MOTOR FULL LOAD AMPS	INDIVIDUAL BRANCH CIRCUIT REQUIRED	SWITCH
ME45MC-11	1/2	1	115	20' (6.1M)	8.6	15.0	Manual
ME45MC-11 30	1/2	1	115	30' (9.1)	8.6	15.0	Manual
ME45MC-11 50	1/2	1	115	50' (15.2)	8.6	15.0	Manual
ME45AC-11	1/2	1	115	20' (6.1)	8.6	15.0	Piggyback Tethered
ME45MC-21	1/2	1	230	20' (6.1)	4.3	15.0	Manual
ME45MC-21 50	1/2	1	230	50' (15.2)	4.3	15.0	Manual
ME45AC-21	1/2	1	230	20' (6.1)	4.3	15.0	Piggyback Tethered

MODEL #	UPC #	DISCHARGE ADAPTER SIZE	SOLIDS HANDLING
ME45MC-11	054128202211	2"	3/4"
ME45MC-11 30	022315345195	2"	3/4"
ME45MC-11 50	022315345201	2"	3/4"
ME45AC-11	022315345218	2"	3/4"
ME45MC-21	022315342354	2"	3/4"
ME45MC-21 50	022315345232	2"	3/4"
ME45AC-21	022315345249	2"	3/4"

INSTALLATION

OVERVIEW

Install the pump on a hard, level surface (cement, asphalt, etc.). Never place the pump directly on earth, clay or gravel surfaces. Install the pump in a sump basin with a minimum diameter of 18" (46cm).

⚠ WARNING Do not lift pump by the power cord. See Cord Lifting Warning below.

PIPING INSTALLATION

Piping must not be smaller than the pump discharge size.

The pump is designed to operate partially or completely submerged in effluent liquids and pump semi-solid fluids up to 3/4" (51mm) in diameter.

When installed in an effluent system, the pipe must be capable of handling semi-solids of at least 3/4" (19mm) in diameter.

The rate of flow in the discharge pipe must keep any solids present in suspension in the fluid. To meet minimum flow requirements (2 feet per second in the discharge line), size the pipe as follows:

PIPE SIZED AT:	HANDLES A FLOW RATE OF:
2" (51 mm)	21 GPM
2-1/2" (64 mm)	30 GPM
3" (76 mm)	48 GPM

When using in an effluent system, install a 2" (51mm) check valve in pump discharge to prevent backflow of liquid into sump basin. The check valve should be a free flow valve that will easily pass solids. Be sure check valve installation complies with local codes.

ELECTRICAL INSTALLATION

For automatic operation, plug or wire the pump into an automatic float switch or duplex controller. The pump will run continuously when plugged directly into an electrical outlet.

Connect or wire pump to its own individual branch circuit with no other outlets or equipment in the circuit. Size fuses or circuit breakers according to this manual's Motor and Cord Specifications table.

⚠ DANGER HAZARDOUS VOLTAGE. CAN SHOCK, BURN, OR KILL. When installing, operating, or servicing this pump, read and follow the safety instructions listed in this manual's Safety Information section.

⚠ WARNING



**Risk of electrical shock.
Can burn or kill.
Do not lift pump by power cord.**

CORD LIFT WARNING

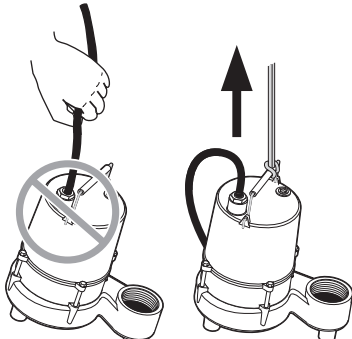

1. Attempting to lift or support pump by power cord can damage cord or connections.
2. Cord may pull apart, exposing bare wires with possibility of fire or electrical shock.
3. Lifting or supporting pump by power cord will void warranty.
4. Use lifting ring or handle on top of pump for all lifting/lowering of pump. Disconnect power to pump before doing any work on pump or attempting to remove pump from sump.

OPERATION & MAINTENANCE

OPERATION

An automatic overload protector in the motor will protect the motor from burning out due to overheating/overloading. When the motor cools down, the overload protector will automatically reset and start the motor.

If the overload trips frequently, check for the cause. It could be a stuck impeller, wrong/low voltage, or an electrical failure in the motor. If an electrical failure in the motor is suspected, have it serviced by a competent repairman.

The pump is permanently lubricated. No oiling or greasing is required.

Cycle the pump at least once every month to be sure that the system is working satisfactorily.

⚠ WARNING **RISK OF FIRE OR EXPLOSION.** Do not use in explosive atmospheres. Pump water only with this pump.

Any of the following actions will void the pump warranty:

- ◆ Do not allow the pump to run in a dry sump. It will void the warranty and may damage the pump.
- ◆ Submerging, plugging, damaging or taping shut a vented cord.
- ◆ Pumping materials other than those the pump was designed to pump or continuously pumping water hotter than 140°F (60°C).
- ◆ Cutting or splicing a power cord or switch cord.
- ◆ Anyone other than an authorized service technician dismantling the pump.
- ◆ Removing the cord tag from the cord.

MAINTENANCE

⚠ WARNING **HAZARDOUS VOLTAGE:** Always disconnect electrical power to the pump and the control switch before removing the pump from the basin for service.

Do not lift the pump by the power cord. See this manual's *Cord Lift Warning*.

DISINFECT PUMP

1. Wear rubber or plastic gloves when handling the pump for service.
2. Place the pump in an area where it can be cleaned thoroughly.
3. Remove all scale and deposits on the pump.
4. Submerge the complete pump in a disinfectant solution (chlorine bleach) for at least one hour before disassembling the pump.
5. The pump motor housing contains a special lubricating oil which should be kept clean and free of water at all times. Whenever the motor housing is being removed for service, remove oil and replace it with new oil at reassembly. Use only oil listed in parts list in this manual. When filling with new oil, DO NOT overfill. Be sure that the oil level is 1/4" above the motor windings.

DISASSEMBLY: IMPELLER REPLACEMENT

1. Remove the oil fill plug from the top of the pump, turn the pump upside down, and drain the oil from the motor housing.
2. Remove 4 bolts holding the upper motor housing to the volute.
3. Tap around the volute with a mallet to loosen it. Lift the pump off the volute, disconnecting the motor leads from the power cord before completely removing the motor cover from the motor.
4. Hold the motor shaft with a screwdriver in the slot on the end of the motor shaft and unscrew the impeller by turning it counterclockwise. Remove the impeller and clean it.
5. If no more service is needed, go to the *Pump Reassembly* instructions.

DISASSEMBLY: SEAL REPLACEMENT

Do not touch the faces of the new seal with your hands. Keep the seal faces free of dirt, grit, or grease during assembly.

1. Follow all steps under *Impeller Replacement* instructions above.
2. Slide the rotating half of the seal off of the motor shaft being careful not to scratch or mar the shaft.

OPERATION & MAINTENANCE

3. Remove four screws from the top of the motor and pull the motor straight up to remove it from the seal plate.
4. Tap the stationary half of the seal out of the seal plate.
5. With a cardboard washer over the carbon face of the seal, press it straight down into the seal cavity in the seal plate.
6. CAREFULLY replace the motor in the seal plate, sliding the motor shaft through the seal without nicking or scratching the seal surface.
7. Replace the 4 bolts in the motor.
8. Slide the rotating half of the seal onto the shaft, carbon face first, being careful not to scratch, nick or chip the seal face.
9. Proceed to *Pump Reassembly* instructions below.

PUMP REASSEMBLY

1. Apply Loctite to the impeller and shaft threads being careful to not get any Loctite on the seal.
2. Screw the impeller onto the shaft (turn clock-wise). Hold the shaft with a screwdriver while you tighten the impeller.
3. Reattach the motor leads to the cord leads.
4. Reassemble the motor cover, motor and seal plate, and volute.
5. Fill the pump with about 1/2 gallon of clean dielectric oil (Part No. U197-8A).

Be sure the oil level is 1/4" above the top of the motor. Allow air space for expansion when the motor warms up.

6. Replace the oil fill plug. The pump is ready for service.

CHECK PUMP GROUND

1. Set the meter to Rx100.
2. Touch one lead to the grounding pin and the other lead to one flat prong of the plug. Repeat for the other prong.
3. Reading should be infinity for both prongs. If the reading is anything other than infinity, the stator must be removed, dried and rechecked.

A reading of "0" indicates a dead short. Return the pump to an authorized distributor, service center, or place of purchase.

CHECK OPERATION

Replace the pump in the sump, connect the plumbing, and then fill the sump to run the pump through one complete operational cycle.

Failure to make this operational check can lead to flooding if the pump requires further attention.

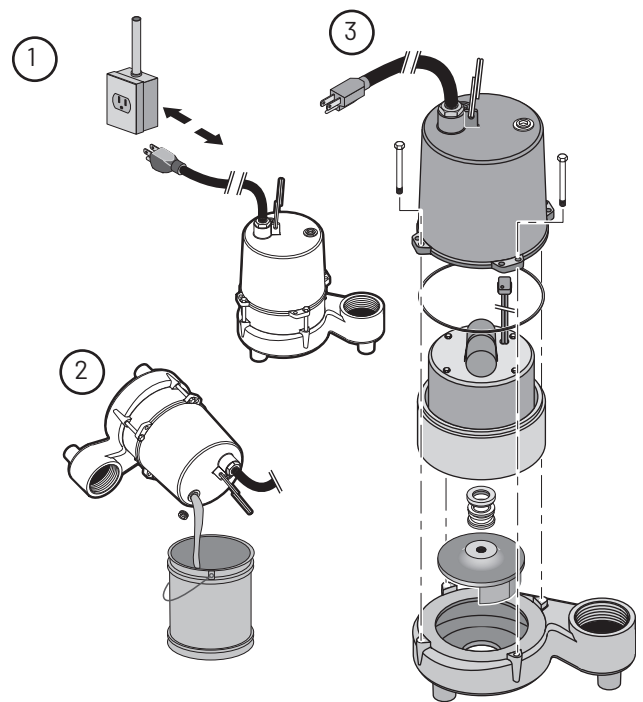
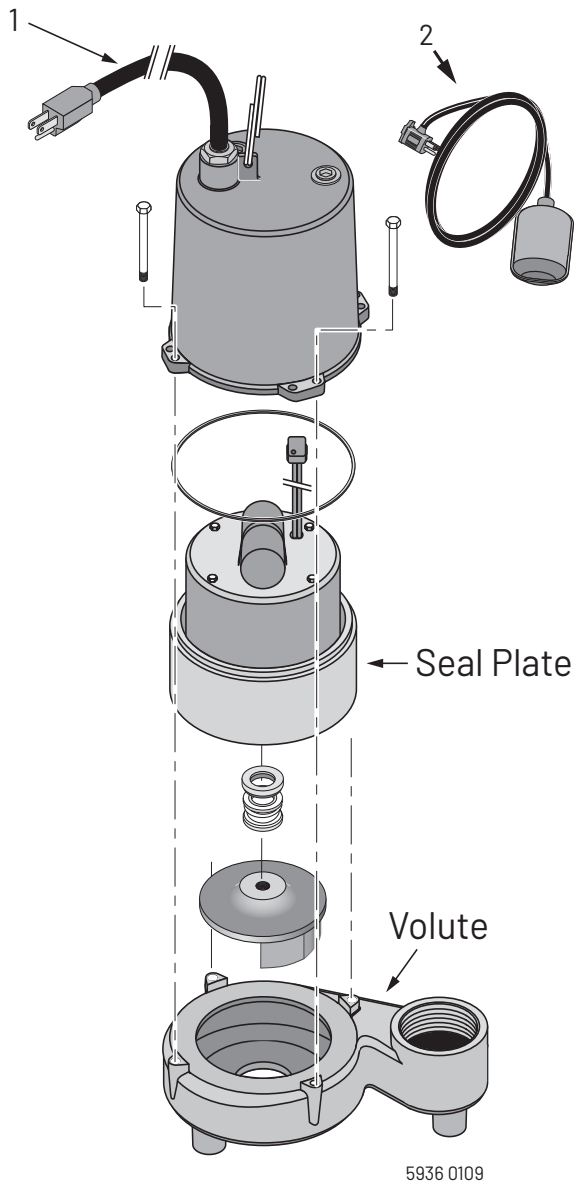

Figure 1 - Pump Disassembly

PARTS LIST



KEY #	DESCRIPTION	QTY	ME45MC-11	ME45MC-11 30	ME45MC-11 50	ME45AC-11	ME45MC-21	ME45MC-21 50	ME45AC-21
1	Cord 115V 20' (6.1m)	1	P117-1510			P117-1510			
1	Cord 230V 20' (6.1m)	1					P117-1511		P117-1511
1	Cord 115V 30' (9.1m)	1		P117-1512					
1	Cord 115V 50' (15.2m)	1			P117-1513			P117-1513	
2	Tethered Float Switch	1				139670207			139670257

* If motor fails, replace entire pump.

TROUBLESHOOTING

TROUBESHOOTING

⚠ WARNING Sudden Starts. If the power is on to the pump when thermal overload resets, the pump may start without warning. If you are working on the pump, you may get an electrical shock or the impeller may catch fingers or tools. Disconnect the power before servicing the pump.

SYMPTOM	CORRECTIVE ACTION
Pump does not operate.	<ol style="list-style-type: none"> 1. Check that unit is securely plugged into outlet, or wired to controller or switch box. 2. Check to be sure you have electrical power and ensure that the piggyback plugs are tight. 3. Check that liquid fluid level is high enough to activate switch or controller. 4. Check to be sure that 1/8" (3 mm) vent hole in discharge pipe is not plugged. 5. Check for blockage in pump inlet, impeller, check valve or discharge pipe. 6. Disconnect the pump from the power source for a minimum of 30 minutes to allow the motor to cool and to protect yourself from sudden starts. See Warning above. Check for the cause of overheating: pump running dry because the float switch is caught up on something; inlet pipe is plugged; outlet pipe is plugged 7. Motor windings may be open. Take unit to authorized service center.
Pump fails to empty sump.	<ol style="list-style-type: none"> 1. Be sure all valves in discharge pipe are fully open. 2. Clean out discharge pipe and check valve. 3. Check for blockage in pump inlet or impeller. 4. Pump not sized properly. A higher capacity pump may be require.
Pump will not shutoff.	<ol style="list-style-type: none"> 1. Check switch or controller automatic floats for proper operation and location. See <i>Installation</i> section for switch/controller instructions. 2. If pump is completely inoperative or continues to malfunction, consult your local serviceman.

WARRANTY

Limited Warranty

Myers® warrants to the original consumer purchaser ("Purchaser" or "You") of the products listed below, that they will be free from defects in material and workmanship for the Warranty Period shown below.

Product	Warranty Period whichever occurs first:
Jet pumps, small centrifugal pumps, submersible pumps and related accessories	12 months from date of original installation, or 18 months from date of manufacture
Fibrewound Tanks	5 years from date of original installation
Steel Pressure Tanks	5 years from date of original installation
Sump/Sewage/Effluent Products	12 months from date of original installation, or 36 months from date of manufacture
Battery Backup Units MBSP-2, MBSP-2C	12 months from date of original installation, or 18 months from date of manufacture
MBSP-3, MBSP-3C	24 months from date of original installation, or 30 months from date of manufacture
Wastewater Solids Handling Pumps	12 months from date of shipment from factory or 18 months from date of manufacture

Our warranty applies only where such products are used in compliance with the requirements of the applicable product catalog and/or manuals. For additional information, please refer to the applicable standard limited warranty featured in the product manual.

Our warranty will not apply to any product that, in our sole judgement, has been subject to negligence, misapplication, improper installation, or improper maintenance. Without limiting the foregoing, operating a three phase motor with single phase power through a phase converter will void the warranty. Note also that three phase motors must be protected by three-leg, ambient compensated, extra-quick trip overload relays of the recommended size or the warranty is void.

Your only remedy, and MYERS's only duty, is that MYERS repair or replace defective products (at MYERS's choice). You must pay all labor and shipping charges associated with this warranty and must request warranty service through the installing dealer as soon as a problem is discovered. No request for service will be accepted if received after the Warranty Period has expired. This warranty is not transferable.

MYERS SHALL NOT BE LIABLE FOR ANY CONSEQUENTIAL, INCIDENTAL, OR CONTINGENT DAMAGES WHATSOEVER.

THE FOREGOING LIMITED WARRANTIES ARE EXCLUSIVE AND IN LIEU OF ALL OTHER EXPRESS AND IMPLIED WARRANTIES, INCLUDING BUT NOT LIMITED TO IMPLIED WARRANTIES OF MERCHANTABILITY AND FITNESS FOR A PARTICULAR PURPOSE. THE FOREGOING LIMITED WARRANTIES SHALL NOT EXTEND BEYOND THE DURATION PROVIDED HEREIN.

Some states do not allow the exclusion or limitation of incidental or consequential damages or limitations on the duration of an implied warranty, so the above limitations or exclusions may not apply to You. This warranty gives You specific legal rights and You may also have other rights which vary from state to state.

This Limited Warranty is effective April 1, 2014 and replaces all undated warranties and warranties dated before April 1, 2014.

F.E. MYERS

293 Wright Street, Delavan, WI 53115

Phone: 888-987-8677 • Fax: 800-426-9446 • www.femyers.com

In Canada: 490 Pinebush Road, Unit 4, Cambridge, Ontario N1T 0A5

Phone: 800-363-7867 • Fax: 888-606-5484

NOTES



293 WRIGHT STREET | DELAVAN, WI 53115 | PH: 866-973-6835 | ORDERS FAX: 800-321-8793 | PENTAIR.COM/MYERS

For a detailed list of where Pentair trademarks are registered, please visit www.pentair.com/en/registrations.html. Pentair trademarks and logos are owned by Pentair plc or its affiliates. Third party registered and unregistered trademarks and logos are the property of their respective owners. Because we are continuously improving our products and services, Pentair reserves the right to change specifications without prior notice. Pentair is an equal opportunity employer.

MY1066 (02-10-20) ©2020 Pentair. All Rights Reserved.