

Take Control.
ION
Technologies



SH30i

Sump Pump

- Basement Sump
- Septic Tank Effluent
- Dewatering



37 Forestwood Dr., Romeoville, IL 60446 www.ionproducts.net [815] 886-9200

Patent No. 8,591,198

SH30i

Sump Pump

System Specifications

Typical Applications	<ul style="list-style-type: none">• Basement sump• Dewatering• Septic tank effluent
Maximum Capacity	Up to 47 GPM
Maximum Head	Up to 35'
Electrical Data	115 V, 1 Ø, 7.0 FLA, 60 Hz
Motor Data	3/10 HP, 3450 RPM
Recommended Minimum Basin Size	18" x 24"
Automatic Operation	i: Ion Digital Level Control (standard) W: Wide angle float V: Vertical float
Manual Operation	M: Manual
Materials of Construction	Cast iron
Impeller	Cast iron vortex
Power Cord	10' Standard
Discharge Size	1½" NPT
Solids Handling	¾"

Pump Dimensions

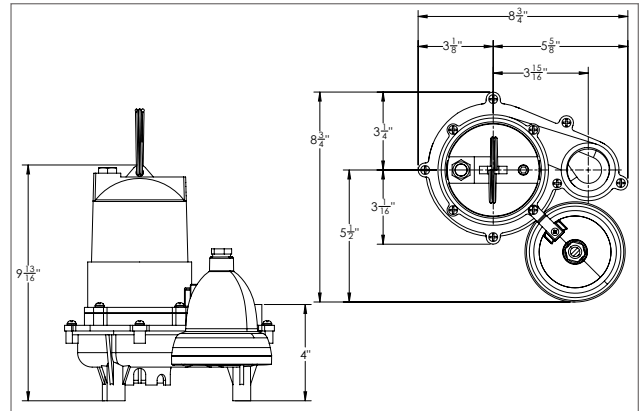

Pump Performance

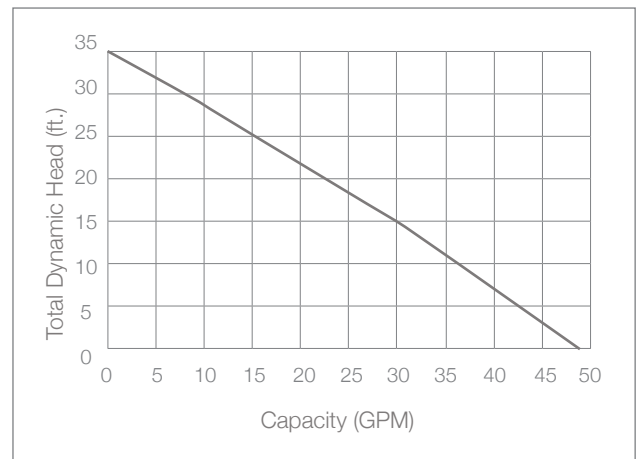

Features

- Carbon ceramic mechanical seal
- Oil-filled motor with automatic reset thermal overload
- Uses single-row ball bearing construction
- Piggy back Ion® digital level control switch has no moving parts (standard)
- 3 year warranty