



# RED LION®

**EN**

**ENGLISH**

## SPRINKLER PUMPS RL-SPRK Series

**Owner's Manual**

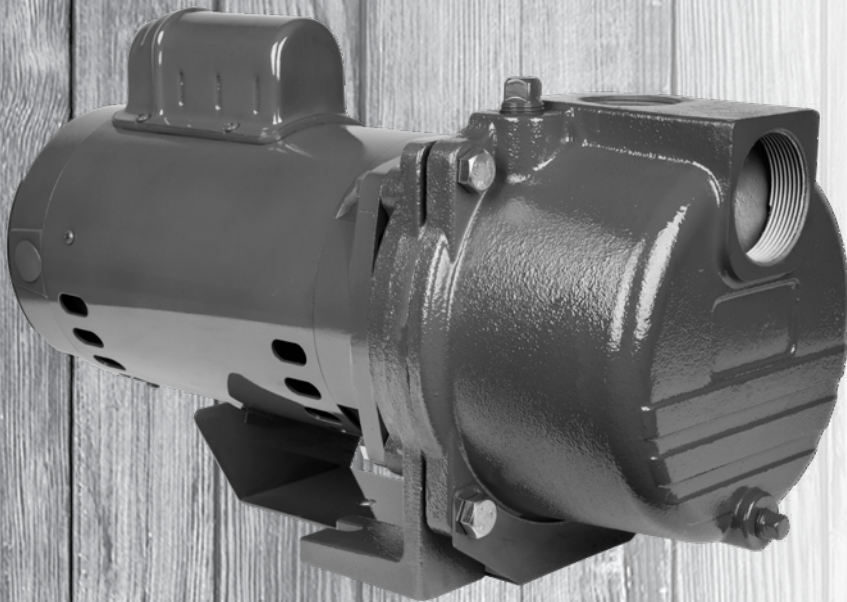

**1 HP AND 1-1/2 HP MODELS ARE DUAL VOLTAGE  
(115/230 VOLTS) AND FACTORY SET FOR 230 VOLTS.**

**SEE VOLTAGE SETTING INSTRUCTIONS TO SET FOR 115 VOLTS.**

### Table of Contents

Before Getting Started .....	2
Introduction.....	3
Plug Descriptions and Socket Sizes.....	3
Voltage Setting Instructions .....	3
Installation .....	4
Operation.....	6
Maintenance.....	7
Troubleshooting.....	8
Replacement Parts .....	9
Limited Warranty.....	10

# BEFORE GETTING STARTED

Read and follow safety instructions. Refer to product data plate(s) for additional operating instructions and specifications.

This is the safety alert symbol. When you see this  symbol on your pump or in this manual, look for one of the following signal words and be alert to the potential for personal injury or property damage if ignored:

 **DANGER** warns about hazards that will cause serious personal injury, death or major property damage if ignored.

 **WARNING** warns about hazards that can cause serious personal injury, death or major property damage if ignored.

 **CAUTION** warns about hazards that will or can cause minor personal injury or major property damage if ignored.

 **NOTICE** indicates special instructions which are important but not related to hazards. Carefully read and follow all safety instructions in this manual and on pump.



**BEFORE OPERATING OR INSTALLING THIS PUMP, READ THIS MANUAL AND FOLLOW ALL SAFETY RULES AND OPERATING INSTRUCTIONS.**

 **WARNING** READ AND FOLLOW ALL SAFETY INSTRUCTIONS.

 **WARNING ELECTRICAL PRECAUTIONS** - All wiring, electrical connections, and system grounding must comply with the National Electrical Code (NEC) and with any local codes and ordinances. Employ a licensed electrician.

 **WARNING FOR DUAL VOLTAGE MOTORS (115/230 V)** - Voltage change instructions are located in this manual.

 **NOTICE** The motor voltage is factory set at 230 V.

 **WARNING RISK OF ELECTRIC SHOCK**

- Have an electrician provide electrical power to motor.
- We recommend that a separate circuit be lead from the home electrical distribution panel, properly protected with a fuse or a circuit breaker.
- A ground fault interrupter (GFI) protected circuit is also recommended for use with any electrical device operating near water.
- For recommended cable size see Table 1.
- Motor must be grounded and terminal cover in place to reduce electrical shock hazard.
- Keep motor operating area as dry as possible.
- Always disconnect power before servicing.
- Not investigated for use in swimming pool areas.

 **WARNING 75 PSI PRESSURE RELIEF VALVE RECOMMENDED**

This pump is capable of producing high pressure. Installing a 75 psi pressure relief valve is highly recommended.

# INTRODUCTION

This pump is ideal for both residential and commercial lawn and turf sprinkler systems. This pump is suitable for installations where the vertical distance from the pump to the water level does not exceed 25 ft (7.6 m), including drawdown (less at high altitudes). In offset installation, friction losses in the suction pipe must be taken into consideration (refer to **Table 2, Friction Loss, page 8**).

This instruction sheet provides you with the information required to safely own and operate your product. Retain these instructions for future reference.

The product you have purchased is of the highest quality workmanship and material, and has been engineered to give you long and reliable service. This product has been carefully tested, inspected, and packaged to ensure safe delivery and operation. Please examine your item(s) carefully to ensure that no damage occurred during shipment. If damage has occurred, please contact the place of purchase. They will assist you in replacement or repair, if required.

**READ THESE INSTRUCTIONS CAREFULLY BEFORE ATTEMPTING TO INSTALL, OPERATE OR SERVICE YOUR PRODUCT. KNOW THE PRODUCT'S APPLICATION, LIMITATIONS, AND POTENTIAL HAZARDS. PROTECT YOURSELF AND OTHERS BY OBSERVING ALL SAFETY INFORMATION. FAILURE TO COMPLY WITH THESE INSTRUCTIONS COULD RESULT IN PERSONAL INJURY AND/OR PROPERTY DAMAGE!**

## PLUG DESCRIPTIONS AND SOCKET SIZES

**⚠ NOTICE** Do not use open style wrenches to loosen plugs. Plugs may become damaged and difficult to remove.

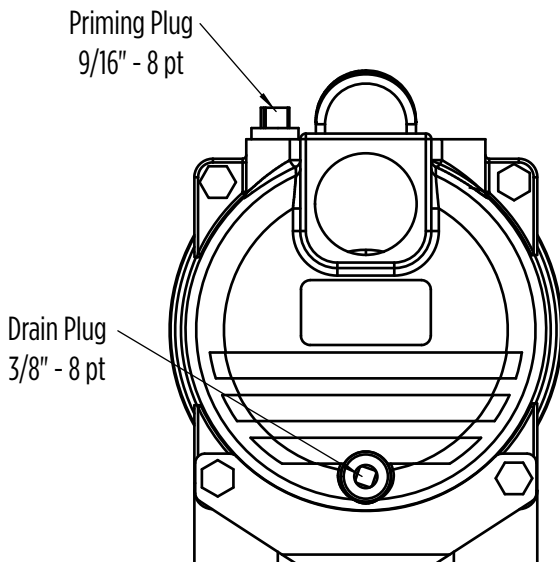

# VOLTAGE SETTING INSTRUCTIONS

To change the pump voltage from the factory setting of 230 volts, a qualified electrician should:

1. Disconnect the power supply to the pump.
2. Remove the cover from the motor terminal box.

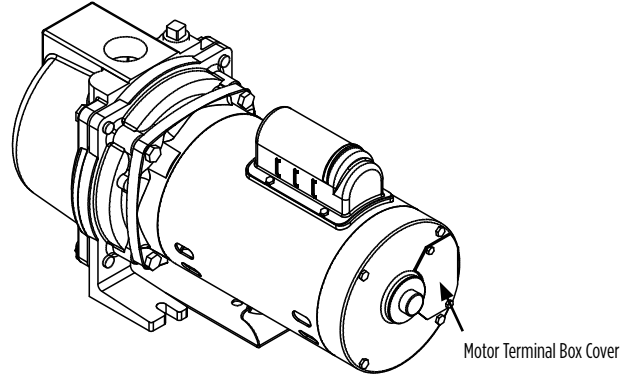

## FOR 1 HP MODELS

### Changing voltage from 230 Volts to 115 Volts:

The cutout in the voltage change indicator will display 230 prominently, as shown below. Insert a flat screwdriver into the black voltage change indicator. To change from 230 Volts to 115 Volts, rotate the voltage change indicator counterclockwise until 115 is displayed in the cutout.

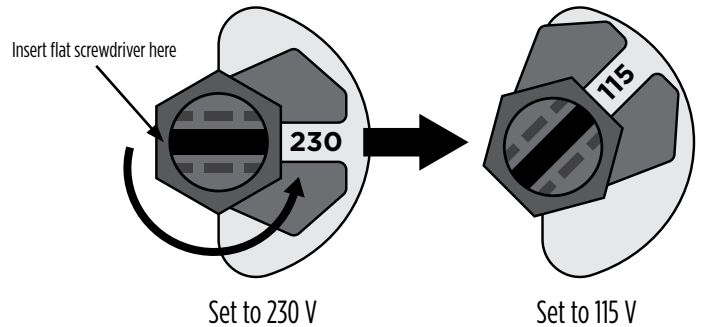

### Changing voltage from 115 Volts to 230 Volts:

The cutout in the voltage change indicator will display 115 prominently, as shown below. Insert a flat screwdriver into the black voltage change indicator. To change from 115 Volts to 230 Volts, rotate the voltage change indicator clockwise until 230 is displayed in the cutout.

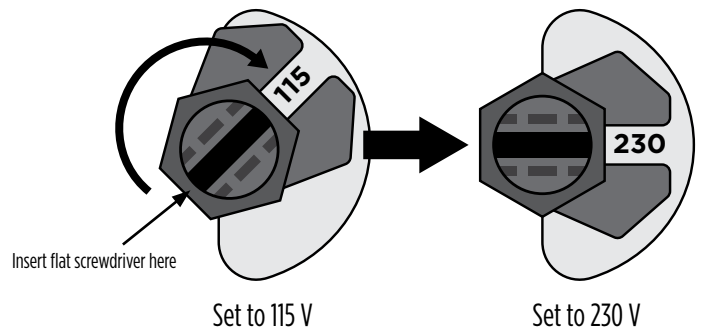

## FOR 1-1/2 HP MODELS

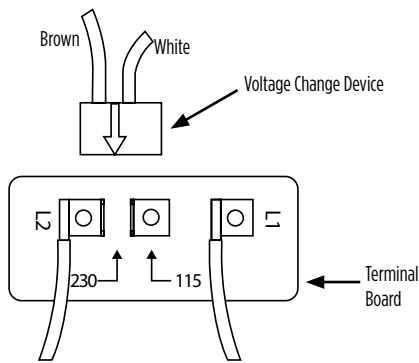

#1

In #1, the motor's switch is shown before the black voltage change device is pressed down onto the voltage terminals.

**NOTE:** DO NOT MOVE LEAD WIRES ON L1 & L2.

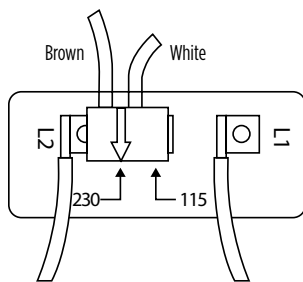

#2 (Set to 230 V)

In #2, the motor's switch is set for 230 V. The white arrow on the voltage change device points directly to the 230 V arrow on the terminal board.

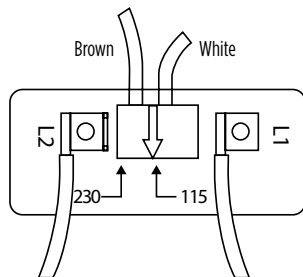

#3 (Set to 115 V)

In #3, the motor's switch is set for 115 V. The white arrow on the voltage change device points directly to the 115 V arrow on the terminal board.

## FOR 2 HP MODELS

2 HP models are available in 230 Volts only.

Table 1

Motor		Wire Gauge (AWG)				
HP	Volts	25 ft (8 m)	50 ft (15 m)	100 ft (30 m)	150 ft (46 m)	200 ft (61 m)
1	115	14	12	10	8	6
	230	14	14	14	14	12
1-1/2	115	12	12	8	6	6
	230	14	14	14	12	12
2	230	14	14	14	12	10

## INSTALLATION

### Pump Location

Install the pump in a clean, dry, and ventilated location that provides adequate drainage, room for servicing, and protection from freezing temperatures.

**CAUTION** The pump must be protected from the elements and freezing temperatures. The motor is not water-resistant.

Bolt down the pump evenly on a good foundation, preferably concrete, to prevent the development of unnecessary stress. Locate the pump as close as possible to the water supply to reduce friction losses in the suction pipe and to provide for maximum capacities. **A foot valve must be used.**

### Suction Pipe

Use only new, clean pipe or hose the same size as that of the pump suction tapping. If the pump is installed any appreciable distance away from the water supply, increase the suction pipe by one size. The suction pipe must always slope upwards from the water source to the pump to avoid air pockets in the line. It is advisable to use a 90° or 45° elbow on the suction line. This enables the pump to prime sooner and also prevents kinking of the hose. A check valve is recommended to ensure easier priming. In cases where a maximum volume of water is required over a prolonged period, the suction line should be led almost horizontally to the pump. Use non-toxic thread compound on all pipe joints, and tighten all connections thoroughly. Connect a strainer to the bottom end of the suction pipe and ensure that it is well submerged at all times.

### WARNING ELECTRICAL PRECAUTIONS

All wiring, electrical connections, and system grounding must comply with the National Electrical Code (NEC) and with any local codes and ordinances. Employ a licensed electrician.

### WARNING RISK OF ELECTRICAL SHOCK

#### Grounding the Motor

Wiring to this pump must be installed and maintained in accordance with the National Electrical Code or your local electric code. If more information is needed, call your local licensed electrician or your power company.

It is recommended that a permanent ground connection be made to the unit using a conductor of appropriate size from a metal underground water pipe or a grounded lead in the service panel. Do not ground to a gas supply line. Do not connect to electric power supply until unit is permanently grounded. Connect the ground wire to the approved ground and then connect to the terminal provided.

### WARNING RISK OF ELECTRICAL SHOCK

**Wiring:** Make sure the voltage and frequency of the power supply agrees with the voltage of the pump. If in doubt, check with the power company. Connect wiring to terminal board located inside motor terminal box cover.

## Single Shallow Well (Figure 4)

The single shallow well (Figure 4) is typically a drilled well with a 4" or 6" steel or plastic casing running vertically into the ground. The surface of the water should not exceed 25 feet in depth.

Connect the foot valve to the first length of suction pipe and lower into well. Add pipe sections as needed, securing them using one of the sealing methods previously mentioned. The foot valve should be AT LEAST 5 feet below the surface of the water to allow for water draw down. Seal the top of the 4" or 6" well casing with a well seal to prevent debris from falling into the well.

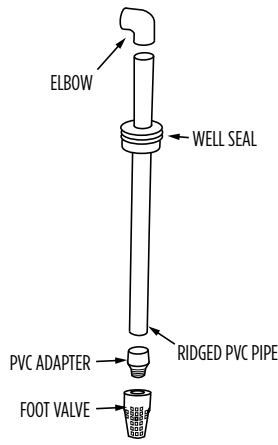

Figure 4

## A. Suction Port Connection (Figure 5)

1. Attach the foot valve or well point to pipe assembly and lower pipe and foot valve until it is at least five feet below the water level. If you are using a well, temporarily clamp the pipe to the well casing to prevent the pipe from sliding into the well. If well is in a 4" or 6" casing, use a well seal at the surface. Never use a suction pipe size smaller than the size of the suction port on the pump.

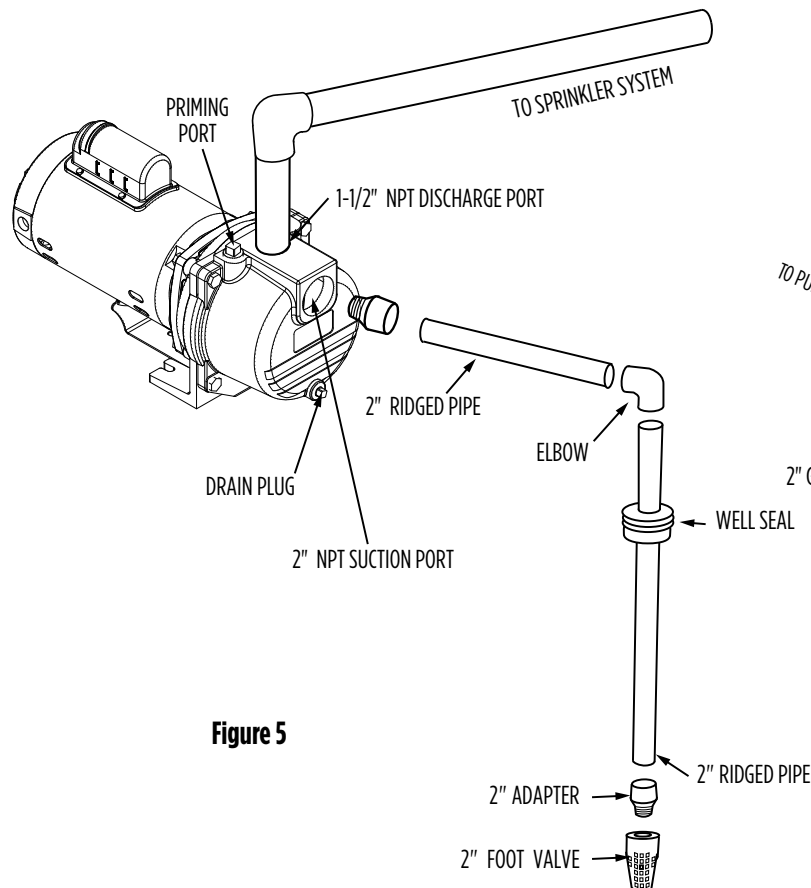

Figure 5

2. Connect the necessary elbows, fittings, check valves, and pipe from the water to the pump suction port on front of pump. When using PVC, pre-assemble pipe and fittings to the pump BEFORE applying PVC cement to ensure proper cuts and inventory. Use PTFE tape on all male threads, wrapping clockwise (when facing pipe) 1 to 2 layers thick. Tighten all threaded pipe fittings until snug. DO NOT OVER-TIGHTEN PIPE AND FITTINGS. Tighten joints hand-tight plus 1/2 turn with pipe wrench.

## B. Discharge Port Connections (Figure 6)

1. Thread male adapter or pipe nipple into discharge port on top of pump. (Use PTFE tape on thread.)
2. Connect pipe between the sprinkler manifold and the pump discharge. Discharge pipe size should increase with long pipe runs. Discharge pipe size may equal discharge port size for distances up to 100'. Increase discharge pipe size by one size for distances of 100' to 300'. For 300' to 600', increase pipe size by two sizes. This will reduce pressure loss caused by friction.
3. Tighten all threaded pipe connections with pipe wrench until snug. Do not over-tighten.

## WELL POINT INSTALLATION

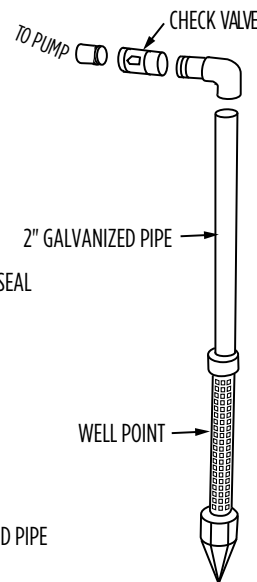

## MULTIPLE WELL POINT INSTALLATION

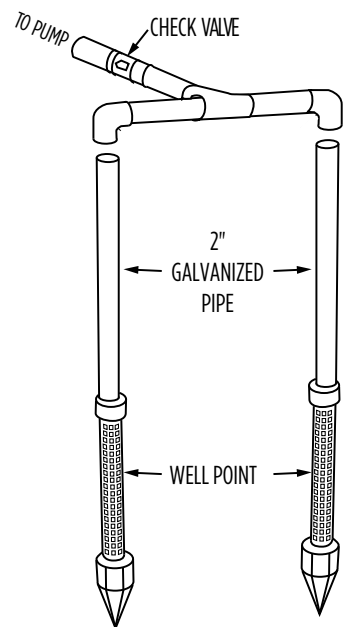

# OPERATION

**⚠ WARNING** DO NOT run pump against a closed discharge. This may cause hazardous pressure and risk of explosion.

**⚠ CAUTION** Do not run the pump before priming it. The seal and impeller could be permanently damaged.

**⚠ CAUTION** DO NOT run the pump before filling the pump case with liquid. Doing so may damage the seal.

**⚠ CAUTION** DO NOT run pump dry. Fill pump with water before starting pump. Operating pump dry may cause damage to pump and will void warranty.

A priming port plug is provided in the top of the casing to fill the pump with water. Once filled and the priming plug replaced, the pump will prime. The priming time depends upon the vertical and horizontal distance between the pump and the water level.

1. Remove priming port plug from pump (Figure 7).
2. Open discharge valves and any hoses on discharge side of pump.
3. Fill pump with water through the priming port on top of pump. Allow trapped air to escape for a few minutes, then add more water until full.
4. Replace priming port plug and tighten with wrench, using PTFE tape on pipe threads.
5. Start the pump. A properly primed pump should discharge water without air at a consistent pressure. If the pump does not produce water after five minutes, stop the pump, release all pressure, remove priming port plug, add more water, replace plug, and try again. Ensure that a foot valve is properly installed on the suction pipe (Figure 5). If an exceptionally long suction line is used, the water in the pump casing may become overheated or vapourlocked. Should this occur, replace the water in the casing with cold water and continue priming.

## **⚠ CAUTION**

Never operate the pump dry as this may damage the seal.

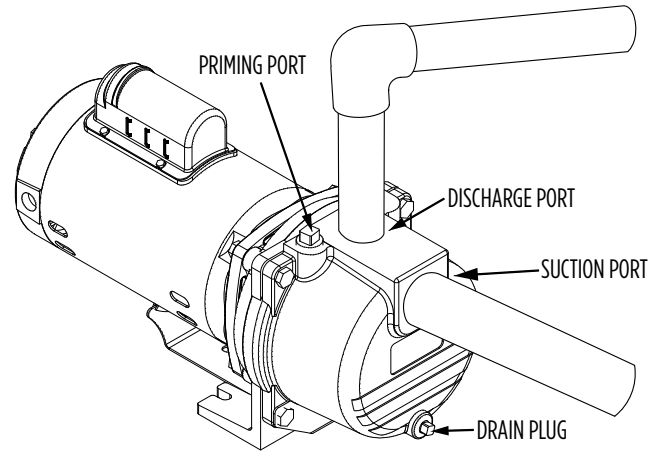

Figure 6

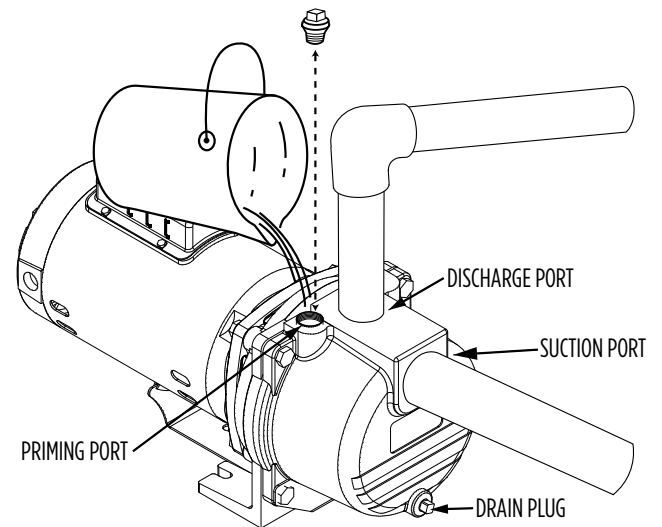

Figure 7

# MAINTENANCE

## **⚠ WARNING ELECTRICAL PRECAUTIONS**

All wiring, electrical connections, and system grounding must comply with the National Electrical Code (NEC) and with any local codes and ordinances. Employ a licensed electrician.

## **⚠ WARNING RISK OF ELECTRICAL SHOCK**

- Have an electrician provide electrical power to the motor.
- Motor must be grounded and terminal cover in place to reduce electrical shock hazard.
- Keep motor operating area as dry as possible.
- A ground fault circuit interrupter (GFCI) protected circuit is recommended for use with any electrical device operating near water.
- Always disconnect power before servicing.
- Not investigated for use in swimming pool areas.

**Lubrication:** The pump requires no lubrication.

## **Draining**

Should the pump be subject to freezing temperatures, it will be necessary to drain the pump completely. To drain, remove the drain plug located at the bottom of the front face of the pump casing and the priming plug and make sure that the drain hole is not restricted. After all the water has been drained, operating the pump for a few seconds will ensure that the impeller is devoid of water (make sure that the suction line is also devoid of water).

## **Pump Storage**

Drain liquid from pump to prevent freezing. It is recommended that a good rust inhibitor be put in the liquid end to prevent excessive corrosion. Be sure motor is kept dry and covered. When restoring the use of the pump, replace all plugs and make sure all connections are tightly sealed. After a complete check is made, make the initial prime according to the OPERATION section.

## **Disassembly**

(See figure 8 from the REPLACEMENT PARTS section.)

1. Shut off the power to the pump at the main service panel and disconnect the power supply from motor.
2. Open a tap in the water system to release the pressure.
3. Remove the drain and fill plugs (8, 10) to allow the pump to drain.
4. Remove the four bolts (9), the casing (11), the gasket (12) and O-ring (6).
5. Remove the screws on the diffuser (7) to separate the diffuser (13) from the motor adapter (3). Remove the cap (16) and insert a screwdriver to prevent the shaft from turning while unscrewing the impeller (5). If impeller cannot be turned by hand, insert a flat object into the impeller vane.

**NOTE:** Use a strap wrench on the impeller eye to remove the impeller.

6. Slip the rotating seal (4) off the impeller hub.
7. To replace the seal seat (4A) remove four bolts to remove the case adapter (3) to separate from the motor (2). Push the seal seat (4A) out of the case adapter from the motor side.

## **Reassembly**

1. Clean all the parts thoroughly before assembling.
2. Lightly lubricate (with soapy water) the rubber cap on the ceramic seal (4) and push it into the adapter (3) using your thumbs only. Make sure the smooth surface of the ceramic seat faces outwards

**NOTE:** If the pump will remain out of service for longer than one week, the seal components must be installed dry (no lubrication).

3. Put the adapter back on the motor with the four bolts removed previously.
4. Lubricate the rotating seal (4) (with soapy water) and slip it onto the impeller hub with the 'carbon' ring towards the ceramic seat. Apply thread locker to shaft threads prior to installing impeller.
5. Replace the impeller (5) and the diffuser (13).
6. Replace the casing (11) making sure that the gasket (12) and O-ring (6) are not damaged and is in place.
7. Reconnect the tubes to the casing and to the pressure switch.
8. Reconnect the power.
9. **Prime pump**, start the pump and check for leaks.

**Table 2 - FRICTION LOSS FOR PLASTIC PIPE\***

Loss of head in feet due to friction per 100 feet of pipe

Nominal Pipe Size U.S. GPM	3/4"	1"	1-1/4"	1-1/2"	2"
4	3.75	1.15	0.30	0.14	-
5	5.66	1.75	0.46	0.22	-
6	7.95	2.45	0.65	0.31	-
7	10.60	3.25	0.86	0.41	-
8	13.50	4.16	1.10	0.52	-
9	16.80	5.17	1.35	0.65	-
10	20.40	6.31	1.67	0.79	0.23
11	24.40	7.58	1.98	0.95	0.27
12	28.60	8.85	2.33	1.10	0.32
14	38.00	11.80	3.10	1.46	0.43
16	48.60	15.10	3.96	1.87	0.55
18	60.50	18.70	4.93	2.33	0.69
20	73.50	22.80	6.00	2.83	0.84

Loss of head in meters due to friction per 100 meters of pipe

Nominal Pipe Size L/Min.	20 mm	25 mm	32 mm	40 mm	50 mm
15	3.7	1.15	0.30	0.13	-
20	5.3	1.64	0.43	0.19	-
25	7.1	2.18	0.56	0.27	-
30	13.5	4.13	1.08	0.49	-
35	16.3	5.00	1.31	0.61	-
40	23.5	7.30	1.90	0.88	0.25
45	28.3	8.74	2.31	1.07	0.29
50	34.2	10.60	2.79	1.32	0.38
55	40.7	12.60	3.32	1.56	0.46
60	48.1	14.90	3.92	1.85	0.54
65	55.7	17.30	4.45	2.15	0.63
70	63.8	19.70	5.20	2.46	0.73
75	72.2	22.40	5.89	2.78	0.83

\*For galvanized pipe, double the figures.

## TROUBLESHOOTING

Problem	Possible Cause	Remedy
Failure to pump	Pump not properly primed.	Make sure pump casing and suction line are full of water. See priming instructions.
	Speed too low.	<b>⚠ WARNING ELECTRICAL PRECAUTIONS.</b> All wiring, electrical connections and system grounding must comply with the National Electrical Code (NEC) and with any local codes and ordinances. Employ a licensed electrician. Check voltage at motor terminals and at meter when pump is operating. If low, refer to wiring instructions or check with your power company. Check loose connections.
	Total head more than for which pump was intended.	A pump designed for higher head needed.
	Suction lift is too great.	Locate pump closer to source of water. Make sure suction piping is large enough.
Reduced capacity and/or head	Air pockets or leaks in suction line.	Check suction piping.
	Clogged impeller.	Remove and clean.
	Strainer too small or clogged.	Use larger strainer or clean.
	Insufficient submergence of suction line.	Add lengths of suction pipe to keep submerged end well below the water surface.
	Excessive suction lift.	If caused by suction pipe friction, enlarge piping.
	Total head more than that for which the pump was intended.	A pump designed for higher head is needed.
Pump loses prime	Excessively worn impeller.	Order replacement parts using Replacement Parts list.
	Air leaks in suction line.	Check suction piping.
	Excessive lift and operating too near shut-off point.	Move pump nearer water level.
Mechanical troubles and noise	Water level drops while pumping, uncovering suction piping.	Check water supply. Add length of pipe to suction to keep submerged end under water.
	Bent shaft and/or damaged bearings.	Take motor to authorized motor repair shop.
	Suction and/or discharge piping not properly supported and anchored.	See that all piping is supported to relieve strain on pump assembly.



# REPLACEMENT PARTS (Figure 8)

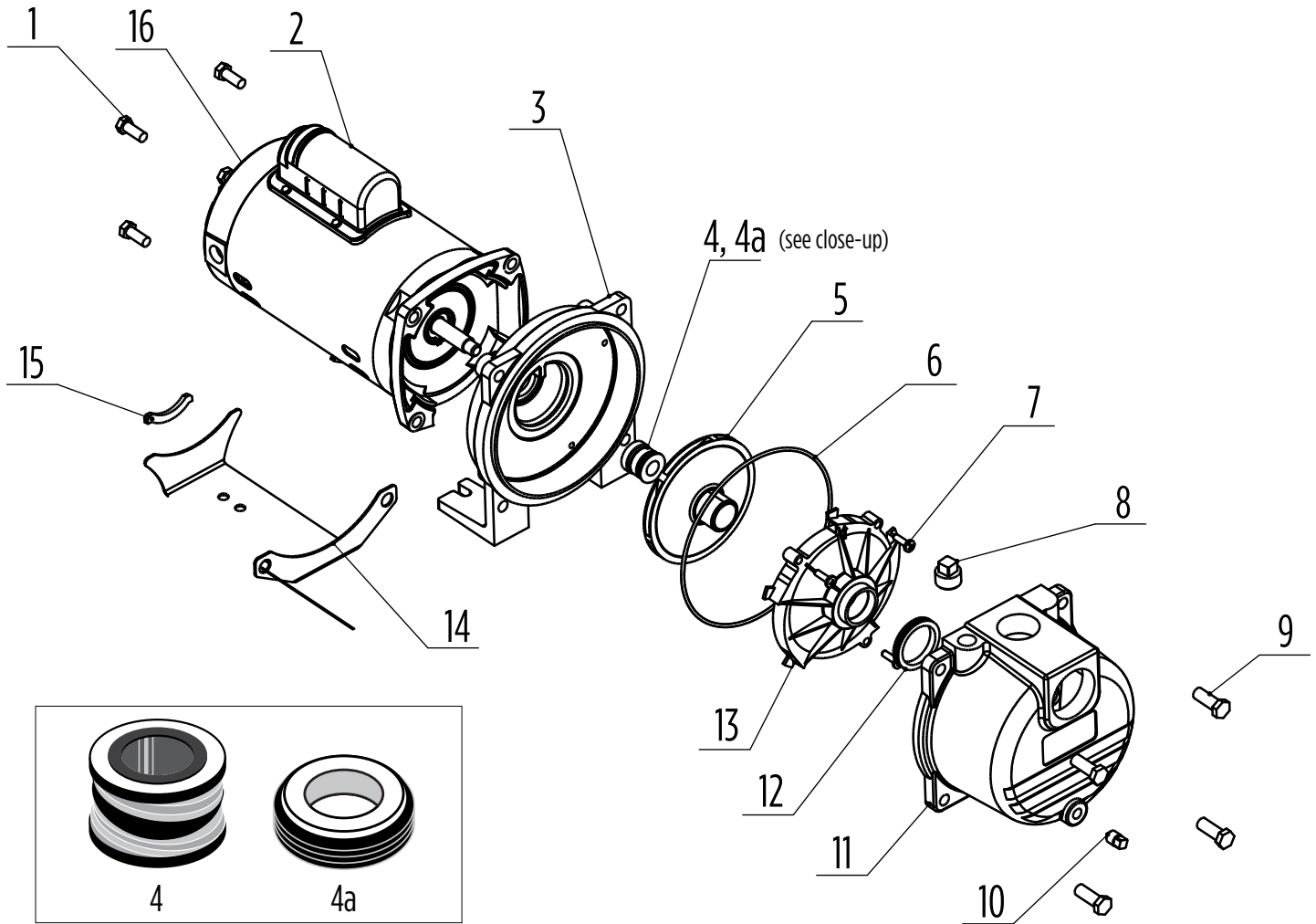

Item #	Description	Where Used	Contents
305606007	Overhaul Kit	RL-SPRK100	4, 4a, 5, 6, 7, 12
305606008	Overhaul Kit	RL-SPRK150	4, 4a, 5, 6, 7, 12
305606009	Overhaul Kit	RL-SPRK200	4, 4a, 5, 6, 7, 12
305606010	Overhaul Kit	RL-SPRK150-BR	4, 4a, 5, 6, 7, 12
305606011	Overhaul Kit	RL-SPRK200-BR	4, 4a, 5, 6, 7, 12
305606001	Casing Kit	All RL-SPRK	11
305606012	Seal Kit	All RL-SPRK	4, 4a, 6, 12
305606013	O-Ring, Gasket, Hardware Kit	All RL-SPRK	1, 6, 8, 9, 10, 15
305606002	Impeller/Diffuser Kit	RL-SPRK100	5, 6, 7
305606003	Impeller/Diffuser Kit	RL-SPRK150	5, 6, 7
305606004	Impeller/Diffuser Kit	RL-SPRK200	5, 6, 7
305606005	Impeller/Diffuser Kit	RL-SPRK150-BR	5, 6, 7
305606006	Impeller/Diffuser Kit	RL-SPRK200-BR	5, 6, 7

# LIMITED WARRANTY

For warranty consideration, the Red Lion® Brand (hereafter “the Brand”) warrants that the products specified in this warranty are free from defects in material or workmanship of the Brand. During the time periods and subject to the terms and conditions hereinafter set forth, the Brand will repair or replace to the original user or consumer any portion of this product which proves defective due to materials or workmanship of the Brand. At all times the Brand shall have and possess the sole right and option to determine whether to repair or replace defective equipment, parts, or components. The Brand has the option to inspect any product returned under warranty to confirm that the warranty applies before repair or replacement under warranty is approved. This warranty sets forth the Brand’s sole obligation and purchaser’s exclusive remedy for defective product. Return defective product to the place of purchase for warranty consideration.

**WARRANTY PERIOD – PRODUCTS:** 24 months from date of purchase by the user (No warranty on brushes, impeller or cam on models with brush-type motors and/or flex-vane impellers). In the absence of suitable proof of the purchase date, the effective period of this warranty will begin on the product’s date of manufacture.

**LABOR, ETC. COSTS:** The Brand shall IN NO EVENT be responsible or liable for the cost of field labor or other charges incurred by any customer in removing and/or affixing any product, part or component thereof.

**PRODUCT IMPROVEMENTS:** The Brand reserves the right to change or improve its products or any portions thereof without being obligated to provide such a change or improvement for units sold and/or shipped prior to such change or improvement.

**GENERAL TERMS AND CONDITIONS:** This warranty shall not apply to damage due to acts of God, normal wear and tear, normal maintenance services and the parts used in connection with such service, lightning or conditions beyond the control of the Brand, nor shall it apply to products which, in the sole judgment of the Brand, have been subject to negligence, abuse, accident, misapplication, tampering, alteration; nor due to improper installation, operation, maintenance or storage; nor to excess of recommended maximums as set forth in the instructions.

Warranty will be VOID if any of the following conditions are found:

1. Product is used for purposes other than those for which it was designed and manufactured
2. Product not installed in accordance with applicable codes, ordinances and good trade practices
3. Product connected to voltage other than indicated on nameplate
4. Pump used to circulate anything other than fresh water at approximately room temperature
5. Pump allowed to operate dry (fluid supply cut off)
6. Sealed motor housing opened or product dismantled by customer

**DISCLAIMER:** Any oral statements about the product made by the seller, the Brand, the representatives or any other parties, do not constitute warranties, shall not be relied upon by the user, and are not part of the contract for sale. Seller’s and the Brand’s only obligation, and buyer’s only remedy, shall be the replacement and/or repair by the Brand of the product as described above. NEITHER SELLER NOR THE BRAND SHALL BE LIABLE FOR ANY INJURY, LOSS OR DAMAGE, DIRECT, INCIDENTAL OR CONSEQUENTIAL (INCLUDING, BUT NOT LIMITED TO, INCIDENTAL OR CONSEQUENTIAL DAMAGES FOR LOST PROFITS, LOST SALES, INJURY TO PERSON OR PROPERTY, OR ANY OTHER INCIDENTAL OR CONSEQUENTIAL LOSS), ARISING OUT OF THE USE OR THE INABILITY TO USE THE PRODUCT, AND THE USER AGREES THAT NO OTHER REMEDY SHALL BE AVAILABLE TO IT. Before using, the user shall determine the suitability of the product for his intended use, and user assumes all risk and liability whatsoever in connection therewith. THE WARRANTY AND REMEDY DESCRIBED IN THIS LIMITED WARRANTY IS AN EXCLUSIVE WARRANTY AND REMEDY AND IS IN LIEU OF ANY OTHER WARRANTY OR REMEDY, EXPRESSED OR IMPLIED, WHICH OTHER WARRANTIES AND REMEDIES ARE HEREBY EXPRESSLY EXCLUDED, INCLUDING BUT NOT LIMITED TO ANY IMPLIED WARRANTY OF MERCHANTABILITY OR FITNESS FOR A PARTICULAR PURPOSE, TO THE EXTENT EITHER APPLIES TO A PRODUCT SHALL BE LIMITED IN DURATION TO THE PERIODS OF THE EXPRESSED WARRANTIES GIVEN ABOVE. Some states and countries do not allow the exclusion or limitations on how long an implied warranty lasts or the exclusion or limitation of incidental or consequential damages, so the above exclusion or limitations may not apply to you. This warranty gives you specific legal rights, and you may also have other rights which vary from state to state and country to country.

---

**For technical assistance, parts, or repair, please  
contact.... 888.885.9254 | [redlionproducts.com](http://redlionproducts.com)**

---



Form 106905105  
Rev. 000  
01/18



**RED LION**