

Product information presented here reflects conditions at time of publication. Consult factory regarding discrepancies or inconsistencies.

TECHNICAL DATA SHEET

Model 519 Multi-Purpose Condensate Pump Series

Automatically removes condensation from air conditioning and 90+ condensing furnaces as well as dehumidifiers, ice makers, water coolers and refrigeration systems.

PRODUCT SPECIFICATIONS

MOTOR	Horse Power	1/30
	Voltage	115
	Phase	1
PUMP	Operation	Automatic
	Discharge Size	3/8"
	Cord Length	6 ft (2m)
	Cord Type	Grounded plug
	Max. Head	20' (6.1 m)
	Max. Flow Rate	110 GPH (416 LPM)
	Max. Operating Temp.	140 °F (60 °C)

- Handles condensate up to 140 °F (60 °C)
- 20 ft (6.1 m) TDH
- Dimensions: 5.6" (14.2 cm) x 7.2" (18.3 cm) x 11.5" (29.1 cm)
- 1/2 gallon (2 liter) capacity
- Built-in safety switch and check valve
- Will automatically shut pump down in event of failure
- Safety switch leads
- Four inlet options

TOTAL DYNAMIC HEAD FLOW PER HOUR

MODEL		519	
Feet	Meters	Gal.	Liters
3	.9	110	416
6	1.8	93	352
9	2.7	77	291
12	3.7	59	223
15	4.6	38	144
18	5.5	16	61
Shut-off Head:		20 ft.(6.1m)	

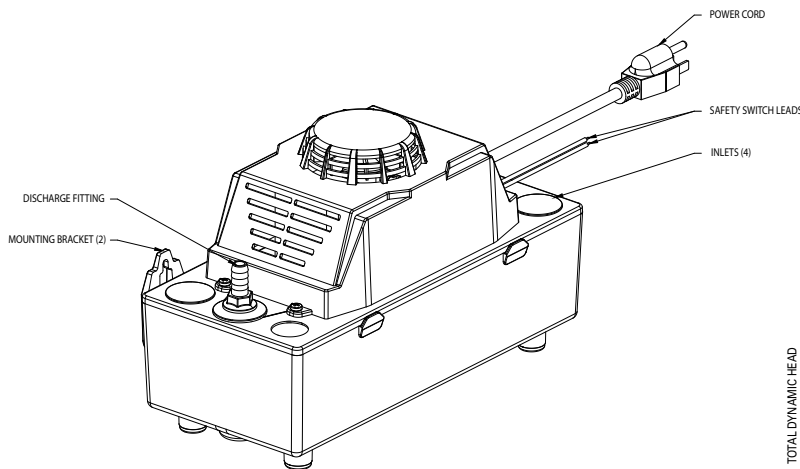

SK3173

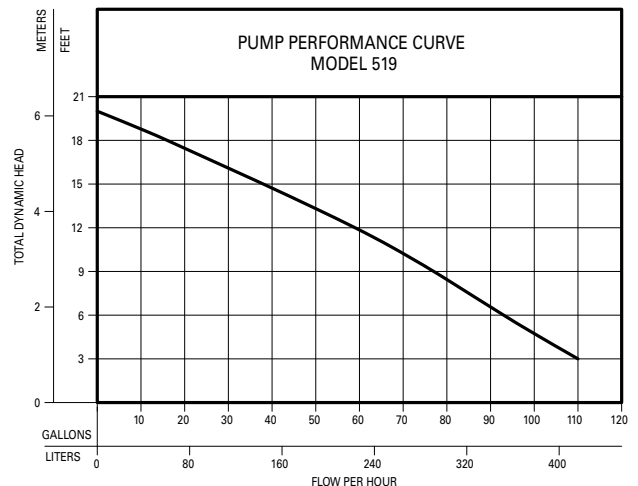

Tested to UL Standard UL778
& Certified to CSA
Standard C22.2 No. 108

155405