

Please read and save this Repair Parts Manual. Read this manual and the General Operating Instructions carefully before attempting to assemble, install, operate or maintain the product described. Protect yourself and others by observing all safety information. The Safety Instructions are contained in the General Operating Instructions. Failure to comply with the safety instructions accompanying this product could result in personal injury and/or property damage! Retain instructions for future reference. AMT reserves the right to discontinue any model or change specifications at any time without incurring any obligation.
©2025 AMT Pump Company, A Subsidiary of The Gorman-Rupp Company, All Rights Reserved.

Periodic maintenance and inspection is required on all pumps to insure proper operation. Unit must be clear of debris and sediment. Inspect for leaks and loose bolts. Failure to do so voids warranty.

Vertical Sealless Sprayer/Washer Pumps



Refer to pump manual 1808-634-00 for General Operating and Safety Instructions.

DESCRIPTION

Vertical sealless sprayer/washer pumps are heavy duty industrial units designed for OEM, automotive and industrial washing machines, parts cleaners, spray booths and cooling towers. Pumps are immersion type; pump end must be immersed in liquid, motor must remain above liquid surface.

All models feature 316 stainless steel semi-open clog resistant impeller, stainless steel shaft, steel shaft coupling, cast iron base and column, plated steel inlet screen, and a TEFC (Totally Enclosed Fan Cooled) electric motor. Motor has ball bearings. Heavy duty steel universal mounting brackets included. Pump design eliminates a bottom bearing and a shaft seal on all models. Pumps handle liquids up to a maximum temperature of 200° F. Maximum ambient temperature 104° F. Liquid viscosity cannot exceed 100 SSU. These are manual units; no controls are supplied. For use with nonflammable liquids compatible with pump component materials.

INSTALLATION

1. (5570 series pumps) Remove shipping fixture (Ref. No. 19) that holds the drive shaft to the base before installing pump.
2. Pump must be installed with its base supporting the entire weight of the pump.

▲ CAUTION

Mounting brackets are not designed to support the pump's weight. Brackets are designed to prevent tipping.

3. Position pump in tank or reservoir. Position mounting brackets, align pipe clearance hole with pump discharge outlet.
4. (4445 series pumps) Assemble one piece of sponge tape (Ref. No. 25) to each clamp bracket (Ref. No. 24). Attach clamp brackets to mounting brackets with fasteners provided (Ref. Nos. 26 and 27). This will fix the column (Ref. No. 3) in position.
5. (5570 series pumps) Adjust lower fasteners (Ref. No. 4) to bottom of mounting brackets. Secure pump to mounting brackets with upper fasteners (Ref. No. 4).
6. Secure mounting brackets to tank or reservoir. Install an appropriate fastener in each hole or slot provided.
7. Install the balance of the system.

MAINTENANCE

▲ WARNING

Make certain that unit is disconnected from power source before attempting to service or remove any component.

IMPELLER/MOTOR REPLACEMENT

Refer to Figure 2, and 3.

1. Remove unit from the tank or reservoir.
2. Remove fasteners (Ref No. 8) and washers if present (Ref. No. 7) that connect the volute base (Ref. No. 17) to the volute cover (Ref. No. 10).
3. Remove volute base, and gasket (Ref. No. 16).
4. Place an allen wrench through the slot in the top of the column and into one of the socket head screws of the shaft coupling. Rotate impeller counterclockwise until allen wrench stops against side of slot. Remove nut (Ref. No. 15) and then impeller from drive shaft by rotating each counterclockwise.

IMPORTANT: Care should be taken to insure that same number of shim washers (Ref. No. 9), if present, is replaced behind impeller as were removed. These shim washers are located directly behind the impeller. Shim washers may or may not be present depending on assembly clearances.

5. Remove allen wrench from slot and then remove the four fasteners (Ref. No. 5) and washers or nuts (Ref. No. 4) that connect the motor (Ref. No. 1) to the column (Ref. No. 3).
6. Remove the motor with shaft (Ref. No. 13) and coupling (Ref. No. 2) from the column.
7. Measure the distance from the shaft coupling to the motor mounting surface. Record this measurement.
8. Loosen the two socket head screws, towards the motor, in the coupling. Slide the coupling/shaft from the motor.
9. To reassemble, slide the coupling/shaft on the motor. Replace drive key (Ref. No. 7) if removed (557X Series only). Position the coupling at the recorded distance from the motor mounting surface. Securely tighten all four socket head screws in coupling.
10. Install motor/shaft assembly into column. Secure with four

Vertical Sealless Sprayer/Washer Pumps

fasteners and washers.

11. Install impeller, shim washers if any, and nut. Position gasket on volute cover and install volute base with fasteners and washers.

IMPORTANT: If impeller strikes volute spacer plate (Ref. No. 11) before bottoming on shaft shoulder, add two 0.020" shims behind impeller. Reinstall impeller.

12. Place pump in an upright position. Rotate shaft/impeller. Impeller cannot strike volute base or volute cover. If interference exists, install or remove shim washers behind the impeller. (See "SHIM ADJUSTMENT" section) If shimming does not correct interference, repositioning coupling/shaft/impeller assembly on motor shaft may be necessary.

VOLUTE SPACER PLATE REPLACEMENT

The volute spacer plate is subject to wear only by abrasive liquids. If badly worn this plate can be replaced easily.

1. Disassemble pump for access as described in IMPELLER/MOTOR REPLACEMENT, steps 1, 2, 3, and 4.
2. Remove two fasteners (Ref. No. 12) that connect the spacer plate to the volute cover.
3. Replace spacer plate.
4. Reassemble pump as described in steps 11 and 12.

SHIM ADJUSTMENT

1. When installing a replacement impeller (Ref. No. 14), motor (Ref. No. 1), volute spacer plate (Ref. No. 11) or volute base (Ref. No. 17), it may be necessary to adjust the number of shims (Ref. No. 9) to insure proper running clearance between impeller and volute base and spacer plate. Proceed as follows:

NOTE: A proper running clearance between impeller and volute base is 0.04" to 0.06".

- a. For impeller or motor replacement, add one 0.020" shim in addition to those removed, if any, originally.
- b. Reassemble pump as described in steps 9, 10, 11, and 12 as described in IMPELLER/MOTOR REPLACEMENT.

IMPORTANT: Insure that volute base is snugly in place and check shaft to make sure it is turning freely (rotate impeller by using impeller nut Ref. No. 15 and socket wrench). Tighten fasteners connecting motor to column and volute to base carefully. Rotate shaft while tightening so that motor bearings are not damaged in the event that too many shims were installed. If shaft seizes before fasteners are completely tight, disassemble pump and remove two shims and repeat assembly.

SHAFT SUPPORT REMOVAL

Models 4445-95 and 4446-95 only. These units are designed to operate without a bottom bearing. A shaft support (Ref. No. 20) is installed at the factory to protect the shaft from misalignment during shipping. If pump is noisy while operating, this support may be the cause. The shaft support can be removed to stop noisy operation. Shaft support should not be replaced.

1. Disassemble pump for access as described in IMPELLER/MOTOR REPLACEMENT, steps 1 through 6.
2. Press out shaft support. Do not remove support plate (Ref. No. 21).
3. Reassemble pump as described in steps 10, 11, and 12.

DEBRIS SCREEN CLEANING

Sprayer/Washer pumps are equipped with a debris screen (Ref. No. 18). This screen is supplied attached to volute base (Ref. No. 17) with 4 drive pins. This screen may be replaced if damaged.

If pump performance is reduced or severe vibration occurs during operation this screen may be clogged. Debris screen must be thoroughly cleaned to restore pump performance.

Vertical Sealless Sprayer/Washer Pumps

For Repair Parts contact dealer where pump was purchased.

Please provide following information:

-Model Number

-Serial Number (if any)

Part description and number as shown in parts list

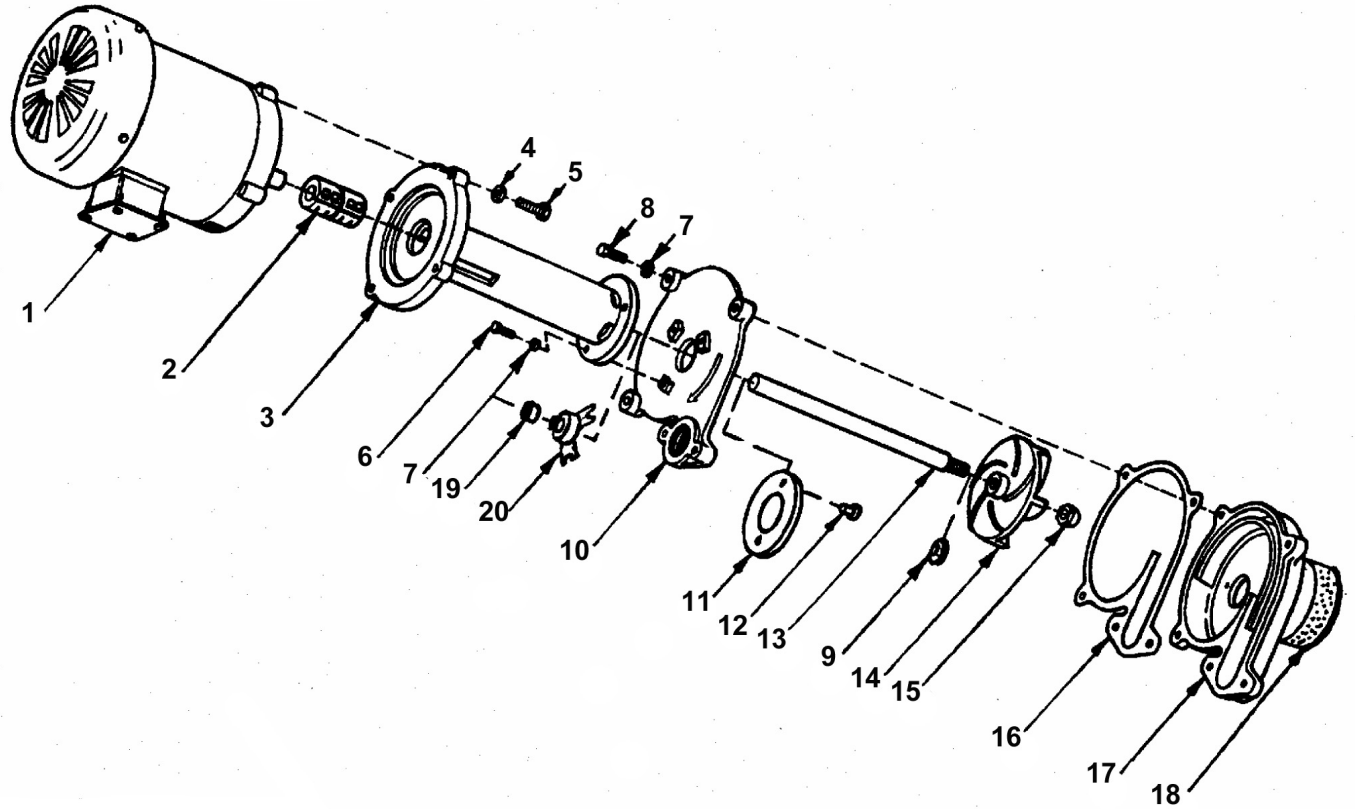

Figure 1 - Repair Parts Illustrations

Repair Parts List

Ref No.	Description	Part Number for Models		Qty
		4445-95	4446-95	
1	Motor	1626-325-00	1627-331-00	1
2	Coupling	4430-143-00	4430-143-00	1
3	Column	4430-032-09	4430-032-09	1
4	Washer	*	*	4
5	Fastener	*	*	4
6	Fastener	*	*	3
7	Washer	Incl. w/Ref. 17	Incl. w/Ref. 17	10
8	Fastener	Incl. w/Ref. 17	Incl. w/Ref. 17	7
9	Impeller Shim Kit	Incl. w/Ref. 14	Incl. w/Ref. 14	1
10	Volute	4440-020-01	4440-020-01	1
11	Volute Spacer Plate	4445-060-09	4445-060-09	1
12	Fastener	*	*	2
13	Shaft	4430-142-01	4430-142-01	1
14	Impeller Kit (includes Ref. Nos. 9, 14 and 15)	4445-010-98	4445-010-98	1
15	Impeller Nut	1784-001-00	1784-001-00	1
16	Gasket	4440-300-00	4440-300-00	1
17	Volute Base Kit (includes Ref. Nos. 7, 8, 17 and 18)	4445-001-95	4445-001-95	1
18	Debris Screen	Incl. w/Ref. 17	Incl. w/Ref. 17	1
19	Shaft Support	2196-004-00	2196-004-00	1
20	Support Plate	4445-090-09	4445-090-09	1
△	Mounting Bracket Kit	4420-90	4420-90	1

(△) Not Shown

(*) Standard hardware item, available locally.

Vertical Sealless Sprayer/Washer Pumps

For Repair Parts contact dealer where pump was purchased.

Please provide following information:

-Model Number

-Serial Number (if any)

Part description and number as shown in parts list

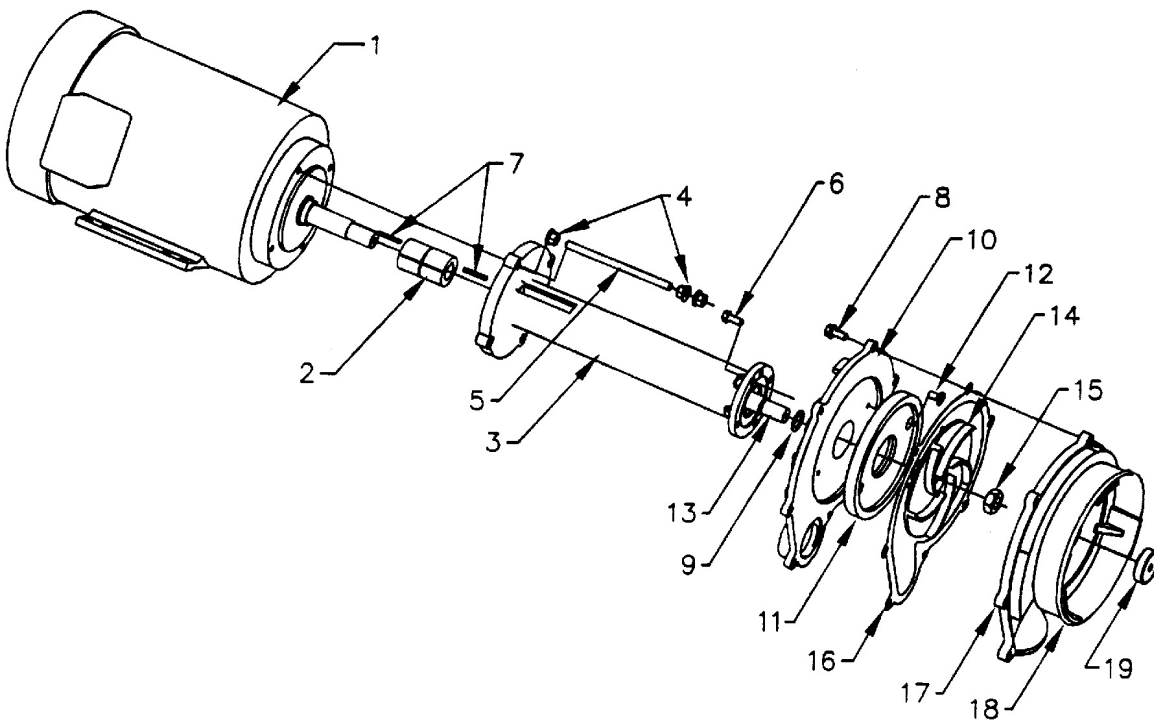

Figure 2 - Repair Parts Illustrations

Repair Parts List

Ref No.	Description	Part Number for Models		Qty
		5571-95	5572-95	
1	Motor	1627-353-00	1627-352-00	1
2	Coupling	5570-141-00	5570-141-00	1
3	Column	4430-032-09	4430-032-09	1
4	Fastener	*	*	12
5	Fastener	*	*	4
6	Fastener	*	*	3
7	Drive Key	1471-030-00	1471-030-00	2
8	Fastener	*	*	7
9	Impeller Shim Kit	1806-090-90	1806-090-90	1
10	Volute	5570-020-01	5570-020-01	1
11	Volute Spacer Plate	5570-060-02	5570-060-03	1
12	Fastener	*	*	2
13	Shaft	5570-140-00	5570-140-00	1
14	Impeller	5570-011-02	5570-011-03	1
15	Impeller Nut	1784-010-00	1784-010-00	1
16	Gasket	5570-300-00	5570-300-00	1
17	Volute Base	4970-001-01	4970-001-01	1
18	Debris Screen	5570-050-00	5570-050-00	1
19	Shipping Fixture	N/A	N/A	1
△	Drive Pin	1697-000-00	1697-000-00	4
△	Mounting Cover	5570-040-00	5570-040-00	2

(△) Not Shown

(*) Standard hardware item, available locally.

(N/A) Not Available

SALES POLICY: AMT Pump Company (herein "AMT") products are sold through our established Distributors. We do not sell direct to the consumer or to any organization not entitled to trade recognition. Therefore, possession of our catalogs and/or price list(s) does not constitute an offer to sell.

MINIMUM ORDER: We appreciate your order, however, all orders are subject to a minimum \$35.00 net invoice charge (excluding freight). This applies to all pump and parts purchase orders.

PRICES: Prices are subject to change without notice. All orders accepted are subject to prices in effect at time of shipment. Price adjustments may be made by Seller to reflect any substantial increases in raw material costs directly attributable to new or increased tariffs imposed by government authorities.

PAYMENT TERMS: Terms, upon establishment of credit, are Net 30 days. Past due accounts are subject to a service charge of 1.5% per month.

PAST DUE ACCOUNTS: AMT reserves the right to withhold open account shipments on any past due account. Invoices are considered past due after thirty (30) days. In the interest of sound business, all orders are subject to approval of the AMT Credit Department.

SHIPPING INSTRUCTIONS: All shipments will be made F.O.B. AMT factory or warehouse. Where instructions for shipment do not appear on the order, the shipment will be made according to our best judgment. Full risk of loss (including transportation delays and losses) shall pass to the customer upon delivery of the products to the carrier at the F.O.B. point. When loss or delay occurs, primary responsibility for tracing rests with the customer. When there is LOSS or APPARENT VISIBLE DAMAGE to a shipment, when tendered for delivery, *DO NOT* give the carrier a clear receipt. Note such damage on the carrier's delivery receipt and *HAVE THE DRIVER SIGN THE RECEIPT*.

PRODUCT REVISIONS: AMT reserves the right to discontinue, change or improve its products or any portions thereof without being obligated to provide such a change or improvement for units sold and/or shipped prior to such a change or improvement.

LEAD TIME: Products designated "Quick Ship Product", also referred to as "QSP" will normally be shipped within 24 hours of receipt of a noncancellable purchase order. Only limited quantities of "QSP" pumps are available.

STANDARD LEAD TIME: Lead time is two weeks for all non "QSP" product. AMT reserves the right to revise lead times as determined by AMT due to availability of materials and all other causes beyond AMT's control.

VIP SHIPMENT: Select AMT and IPT branded pumps are available for rush shipment and subjected to a specific model surcharge per unit noted in the respective price book. This requires calling for availability, confirmation and a non-cancellable purchase order or credit card payment prior to shipment. The expedited shipping charges are an additional cost added separately from the VIP charges per item. AMT reserves the right to revise lead times as determined by AMT due to availability of materials and all other causes beyond AMT's control. QSP quantities are limited as determined by AMT.

ALL purchase orders must be submitted via hard copy sent to AMT customer service department by fax, EDI or e-mail.

RETURN GOODS POLICY: Goods shall not be returned without a return goods authorization number (RGA) issued by AMT customer service. The RGA number must be listed on the packing list. Only current model and part numbers with a valid date code may be

returned (within one year from date of purchase). **A 20% restocking and packaging charge will apply to all returns. All shipping charges must be pre-paid. No exceptions.**

ORDER CHANGES BY CUSTOMER: Orders in process may not be changed except with written consent and may be subject to special charges.

DAMAGES; LIMITATION OF LIABILITY: The aggregate total liability of AMT and all of its assigns, affiliates, employees, insurers and underwriters (the "AMT Parties" in connection with the performance of this order, whether for breach of contract or the Limited Warranty, negligence or otherwise, shall not exceed the amount of the purchase price of the product or part(s) in respect to which such damages are claimed. Buyer agrees to indemnify and hold harmless the AMT Parties from all claims by third parties in excess of these limitations and from all claims resulting from any act or omission of Buyer. IN NO EVENT SHALL AMT OR THE AMT PARTIES BE LIABLE WHETHER BY WAY OF INDEMNITY OR BREACH OF CONTRACT OR STATUTORY DUTY OR REASON OF TORT, FOR ANY LIQUIDATED, DIRECT, INDIRECT, SPECIAL, CONSEQUENTIAL, INCIDENTAL, PUNITIVE, OR EXEMPLARY DAMAGES OR LOSS OF PROFIT, SAVINGS, REVENUE, INCOME, BUSINESS, PRODUCTION, OPPORTUNITY OR REPUTATION ARISING OUT OF OR RELATED TO THE ORDER OR THE GOODS WHETHER FORESEEABLE OR UNFORESEEABLE OR KNOWN OR UNKNOWN.

The right of subrogation against the AMT Parties, to the extent permitted by law, is waived.

WAIVER OF JURY TRIAL. BUYER IRREVOCABLY WAIVES ANY AND ALL RIGHT TO TRIAL BY JURY IN ANY LEGAL PROCEEDING ARISING OUT OF OR RELATED TO THESE TERMS, THE LIMITED WARRANTY OR ANY ORDER HEREUNDER.

GENERAL: These Terms and the Limited Warranty together with any acknowledgement or invoice from AMT, constitute the complete and exclusive statement of the terms of the agreement governing the sale by AMT to Buyer, unless otherwise agreed by AMT in writing. These Terms supersede all other communications, negotiations, and all prior oral or written statements, regarding the subject matter hereof.

SECURITY INTEREST: Buyer grants AMT a security interest in and a lien upon all goods sold to Buyer by AMT and the proceeds therefor (including any insurance proceeds), which security interest shall continue until all such goods are fully paid for in immediately available funds.

GOVERNING LAW: These Terms and any order hereunder shall be construed in accordance with the laws of the State of Delaware, without regard to conflicts of law principles. Any dispute arising hereunder shall be resolved in the federal or state courts of the State of Delaware, as applicable.

MISCELLANEOUS: These Terms may be amended only as agreed to by AMT in writing. The section titles in these Terms are for reference only and shall not limit or restrict the interpretation or construction of the Terms. AMT's failure to insist, in any one or more instances, upon Buyer's performance of any of the Terms, or to exercise any rights conferred by the Terms, shall not constitute a waiver of any such right to insist upon such performance or exercise such rights in the future. The partial or complete invalidity of any one or more provisions of these Terms shall not affect the validity or continuing force and effect of any other provision.

EXTENT AND DURATION OF LIMITED WARRANTY

Coverage: AMT Pump Company (herein "AMT") or IPT Pumps by Gorman-Rupp (herein "IPT") each individually warrants that its products and parts shall be free from defects in material and workmanship for twelve (12) months from the date of purchase by the original end user when installation is made and maintenance is performed in accordance with AMT's recommendations. Wear and tear resulting from use and items normally consumed in use are not covered.

EXCEPTIONS

(A) This Limited Warranty shall not apply to mechanical seals in AMT or IPT pumps and the following products and parts: engines, motors, trade accessories and all other products, components, parts and materials not manufactured by AMT or one of the AMT Parties. These items may, however, be covered by the warranties of their respective manufacturers.

(B) This warranty does not extend to or apply to any unit which has been repaired or altered at any place other than by AMT, or by persons not expressly approved by AMT to make repairs or alterations, nor to any unit the serial number, model number or identification of which has been removed, defaced or altered.

(C) This warranty does not extend to any product manufactured by AMT, which has been subjected to mis-use, neglect, accident, improper installation, or use in violation of instructions furnished by AMT.

(D) Pump Kits: This warranty does not extend to any product sold by AMT unassembled as a Pump Kit. Pump Kits are warranted against defects in material and workmanship for 60 days from the date of shipment from AMT. Any Pump Kit parts deemed defective by AMT will be replaced free of charge within 60 days of shipment. Pump Kits are not returnable for credit.

LIMITATIONS

AMT'S SOLE AND EXCLUSIVE WARRANTY WITH RESPECT TO THEIR PRODUCTS AND PARTS IS THIS LIMITED WARRANTY. THIS LIMITED WARRANTY IS IN LIEU OF ALL OTHER EXPRESS AND/OR IMPLIED WARRANTIES, INCLUDING BUT NOT LIMITED TO IMPLIED WARRANTIES OF MERCHANTABILITY AND FITNESS FOR PARTICULAR PURPOSE.

EXCLUSIVE REMEDY AND DAMAGES

The sole and exclusive remedy for breach of this Warranty by AMT and the entire extent of its liability for such breach or for damages arising from the use of the products and parts covered under this Limited Warranty, shall be as follows:

1. Repair or Replacement: If inspection shows that any AMT product or part covered under this Limited Warranty is defective in materials or workmanship, AMT shall repair or replace the defective or nonconforming product or part without charge, whichever AMT chooses.
2. To obtain the above remedy:
 - a. Immediately notify AMT upon discovery of the claimed defect in materials or workmanship and provide the serial number or date code of the product and/or part(s) or provide AMT with the invoice or bill of sale referencing the product by no later than the expiration date of the warranty period.
 - b. AMT will advise whether inspection will be necessary and how whether repair or replacement will be made. If inspection AMT is necessary, the pump or defective part must be sent freight pre-paid to AMT. Return shipment will be F.O.B. AMT's plant.
 - c. Return Goods Authorization Requirement: No product will be accepted for return or replacement without the prior written authorization of AMT. Upon such authorization, and in accordance with instructions from AMT, the product will be returned to AMT, shipping charges prepaid by the Buyer.