

# BARNES®

## INSTALLATION and OPERATION MANUAL Submersible Sewage Ejector

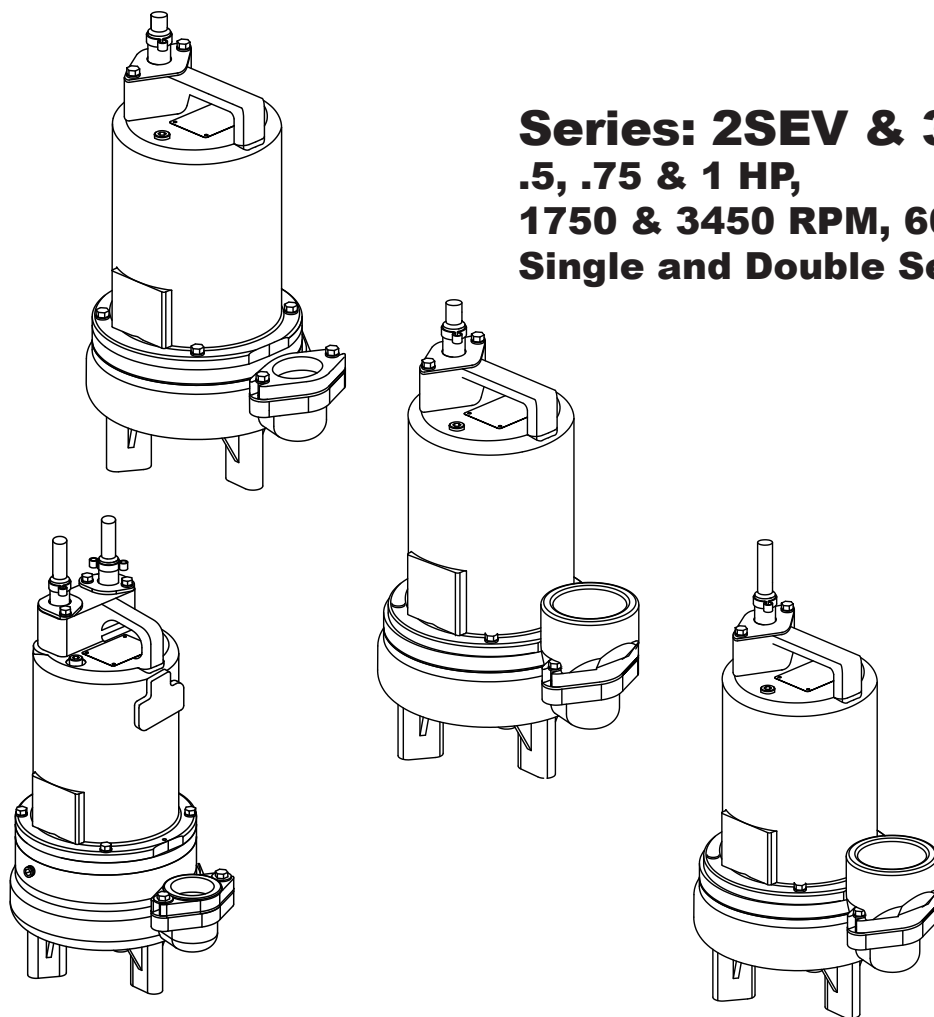

**Series: 2SEV & 3SEV, L & DS**  
**.5, .75 & 1 HP,**  
**1750 & 3450 RPM, 60 Hz.**  
**Single and Double Seal**

**IMPORTANT!**

*Read all instructions in this manual before operating pump.  
As a result of Crane Pumps & Systems, Inc., constant product improvement program,  
product changes may occur. As such Crane Pumps & Systems reserves the right to  
change product without prior written notification.*

**CRANE**

A Crane Co. Company

**PUMPS & SYSTEMS**

420 Third Street  
Piqua, Ohio 45356  
Phone: (937) 778-8947  
Fax: (937) 773-7157  
www.cranepumps.com

83 West Drive, Bramton  
Ontario, Canada L6T 2J6  
Phone: (905) 457-6223  
Fax: (905) 457-2650



Form No. 105241-Rev. AG

# TABLE OF CONTENTS

SAFETY FIRST .....	3
A. PUMP SPECIFICATIONS .....	4 - 5
B. GENERAL INFORMATION .....	6
C. INSTALLATION .....	6 - 10
ELECTRICAL DATA .....	8 - 9
D. START-UP OPERATION .....	10
E. PREVENTATIVE MAINTENANCE .....	10
F. SERVICE and REPAIR .....	11 - 16
G. REPLACEMENT PARTS.....	15
TROUBLE SHOOTING .....	17
SINGLE SEAL - CROSS-SECTION (Fig. 16) .....	18
SINGLE SEAL - EXPLODED VIEW (Fig. 17) .....	19
DOUBLE SEAL - CROSS-SECTION (Fig. 18).....	20
DOUBLE SEAL - EXPLODED VIEW (Fig. 19).....	21
PARTS LIST .....	22 - 24
RETURNED GOODS POLICY.....	28
WARRANTY .....	27
WARRANTY REGISTRATION	
SPECIAL TOOLS AND EQUIPMENT	
INSULATION TESTER (MEGGER)	
DIELECTRIC TESTER	
SEAL TOOL KIT ( see parts list)	
PRESSURE GAUGE KIT (see parts list)	

# SAFETY FIRST!

Please Read This Before Installing Or Operating Pump.  
This information is provided for **SAFETY and to PREVENT EQUIPMENT PROBLEMS**. To help recognize this information, observe the following symbols:



**IMPORTANT!** Warns about hazards that can result in personal injury or Indicates factors concerned with assembly, installation, operation, or maintenance which could result in damage to the machine or equipment if ignored.

**CAUTION !** Warns about hazards that can or will cause minor personal injury or property damage if ignored. Used with symbols below.

**WARNING !** Warns about hazards that can or will cause serious personal injury, death, or major property damage if ignored. Used with symbols below.



Hazardous fluids can cause fire or explosions, burnes or death could result.



Extremely hot - Severe burnes can occur on contact.



Biohazard can cause serious personal injury.



Hazardous fluids can Hazardous pressure, eruptions or explosions could cause personal injury or property damage.



Rotating machinery Amputation or severe laceration can result.



Hazardous voltage can shock, burn or cause death.

Only qualified personnel should install, operate and repair pump. Any wiring of pumps should be performed by a qualified electrician.

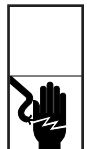

**WARNING ! -** To reduce risk of electrical shock, pumps and control panels must be properly grounded in accordance with the National Electric Code (NEC) or the Canadian Electrical Code (CEC) and all applicable state, province, local codes and ordinances.



**WARNING! -** To reduce risk of electrical shock, always disconnect the pump from the power source before handling or servicing. Lock out power and tag.



**WARNING!** Operation against a closed discharge valve will cause premature bearing and seal failure on any pump, and on end suction and self priming pump the heat build may cause the generation of steam with resulting dangerous pressures. It is recommended that a high case temperature switch or pressure relief valve be installed on the pump body.



**CAUTION !** Never operate a pump with a plug-in type power cord without a ground fault circuit interrupter.



**CAUTION!** Pumps build up heat and pressure during operation-allow time for pumps to cool before handling or servicing.



**WARNING! - DO NOT** pump hazardous materials (flammable, caustic, etc.) unless the pump is specifically designed and designated to handle them.



Do not block or restrict discharge hose, as discharge hose may whip under pressure.



**WARNING! - DO NOT** wear loose clothing that may become entangled in the impeller or other moving parts.



**WARNING! -** Keep clear of suction and discharge openings. **DO NOT** insert fingers in pump with power connected.



Always wear eye protection when working on pumps.



Make sure lifting handles are securely fastened each time before lifting. **DO NOT** operate pump without safety devices in place. Always replace safety devices that have been removed during service or repair. Secure the pump in its operating position so it can not tip over, fall or slide.



**DO NOT** exceed manufacturers recommendation for maximum performance, as this could cause the motor to overheat.



**DO NOT** remove cord and strain relief. Do not connect conduit to pump.



**WARNING!** Cable should be protected at all times to avoid punctures, cut, bruises and abrasions - inspect frequently. Never handle connected power cords with wet hands.



**WARNING!** To reduce risk of electrical shock, all wiring and junction connections should be made per the NEC or CEC and applicable state or province and local codes. Requirements may vary depending on usage and location.



**WARNING!** Submersible Pumps are not approved for use in swimming pools, recreational water installations, decorative fountains or any installation where human contact with the pumped fluid is common.



**WARNING!** Products Returned Must Be Cleaned, Sanitized, Or Decontaminated As Necessary Prior To Shipment, To Insure That Employees Will Not Be Exposed To Health Hazards In Handling Said Material. All Applicable Laws And Regulations Shall Apply.



Bronze/brass and bronze/brass fitted pumps may contain lead levels higher than considered safe for potable water systems. Lead is known to cause cancer and birth defects or other reproductive harm. Various government agencies have determined that leaded copper alloys should not be used in potable water applications. For non-leaded copper alloy materials of construction, please contact factory.



**IMPORTANT! -** Crane Pumps & Systems, Inc. is not responsible for losses, injury, or death resulting from a failure to observe these safety precautions, misuse or abuse of pumps or equipment.

**SECTION: A - PUMP SPECIFICATIONS:**

**DISCHARGE** ..... 2" NPT, Vertical, Bolt-on Flange  
 3" NPT, Vertical, Bolt-on Flange

**LIQUID TEMPERATURE** 104°F (40°C) Continuous

**MOTOR HOUSING** ..... Cast Iron ASTM A-48, Class 30

**VOLUTE** ..... Cast Iron ASTM A-48, Class 30

**SEAL PLATE** ..... Cast Iron ASTM A-48, Class 30

**IMPELLER** *Design* ..... Vortex, Open with Pump out vanes on Back side. Dynamically balanced, ISO G6.3  
*Material* ..... Cast Iron ASTM A-48, Class 30

**SHAFT** ..... 416 Stainless Steel

**SQUARE RINGS** ..... Buna-N

**HARDWARE** ..... 300 Series Stainless Steel

**PAINT** ..... Air dry enamel, top coat

**SEAL** *Design* ..... Single Mechanical, or Tandem Mechanical with oil filled reservoir  
*Material* ..... Rotating Faces - Carbon  
 Stationary Faces - Ceramic  
 Elastomer - Buna-N  
 Hardware - 300 series stainless steel

**CORD ENTRY** ..... 2" NPT, 20 ft. (6.1m)  
 3" NPT, 30 ft. (9.1m)  
 Cord. Plug on 120 volt & .5Hp, 240 volt 1 Phase. Quick connect. Custom molded for sealing and strain relief

**SPEED** ..... 1750 & 3450 RPM, 60Hz (nominal)

**UPPER BEARING:**  
*Design* ..... Single Row, Ball, Oil Lubricated  
*Load* ..... Radial

**LOWER BEARING:**  
*Design* ..... Single Row, Ball, Oil Lubricated  
*Load* ..... Radial & Thrust

**MOTOR:** *Design* ..... NEMA L, Single phase,  
 NEMA B, Three Phase Torque Curve,  
 Oil Filled, Squirrel Cage Induction  
*Insulation* ..... Class B  
 Class F on selected models

**SINGLE PHASE** ..... Permanent Split Capacitor (PSC)  
 Includes overload protection in motor

**THREE PHASE** ..... 200-240/480 is Tri voltage motor.  
 600V. Requires overload protection to be included in control panel

**OPTIONAL EQUIPMENT:**  
 Seal Material, Impeller Trims, Additional Cord, N/C Temperature Sensors with cord for 3 Phase pumps (Requires relay in Control Panel). N/O Moisture Sensor with cord for DS pumps (Requires relay in Control Panel), 3" NPT Discharge Adapter

**2SEV-L Series**

inches  
(mm)

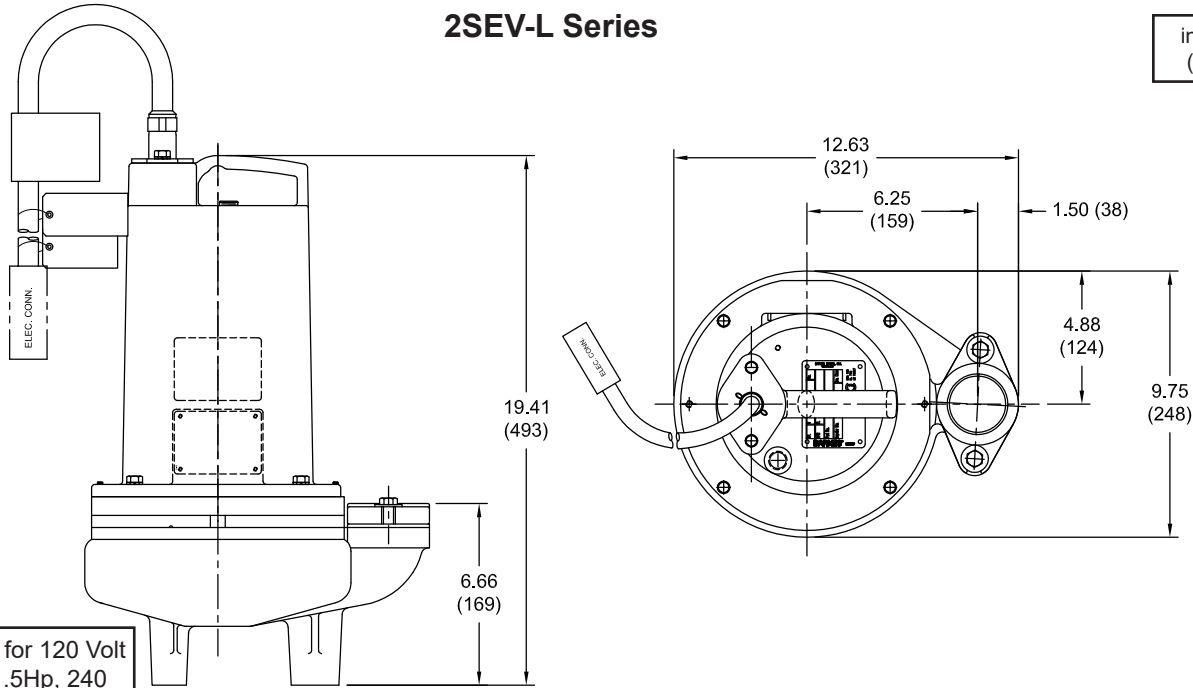

Plugs for 120 Volt and .5Hp, 240 Volt Single Phase Models.

**IMPORTANT !**

- 1.) PUMP MAY BE OPERATED "DRY" FOR EXTENDED PERIODS WITHOUT DAMAGE TO MOTOR AND/OR SEALS.
- 2.) THIS PUMP IS APPROPRIATE FOR THOSE APPLICATIONS SPECIFIED AS CLASS I DIVISION II HAZARDOUS LOCATIONS.
- 3.) THIS PUMP IS NOT APPROPRIATE FOR THOSE APPLICATIONS SPECIFIED AS CLASS I DIVISION I HAZARDOUS LOCATIONS.
- 4.) INSTALLATIONS SUCH AS DECORATIVE FOUNTAINS OR WATER FEATURES PROVIDED FOR VISUAL ENJOYMENT MUST BE INSTALLED IN ACCORDANCE WITH THE NATIONAL ELECTRIC CODE ANSI/NFPA 70 AND/OR THE AUTHORITY HAVING JURISDICTION. THIS PUMP IS NOT INTENDED FOR USE IN SWIMMING POOLS, RECREATIONAL WATER PARKS, OR INSTALLATIONS IN WHICH HUMAN CONTACT WITH PUMPED MEDIA IS A COMMON OCCURRENCE.

## 2SEV-DS Series

inches  
(mm)

Plugs for 120 Volt  
and .5Hp, 240  
Volt Single Phase  
Models.

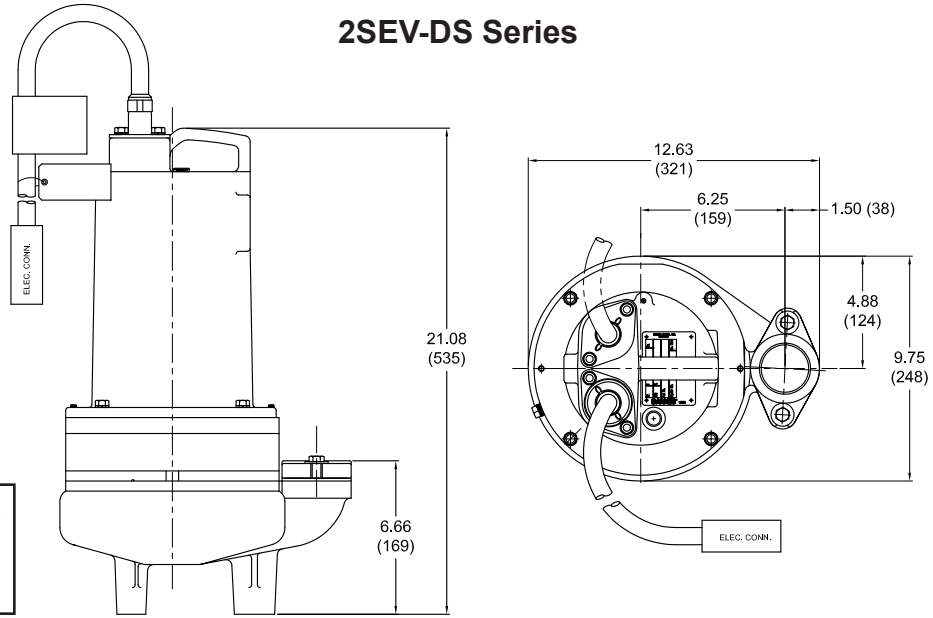

## 3SEV-L Series

Plugs for 120  
Volt and .5Hp,  
240 Volt Single  
Phase Models.

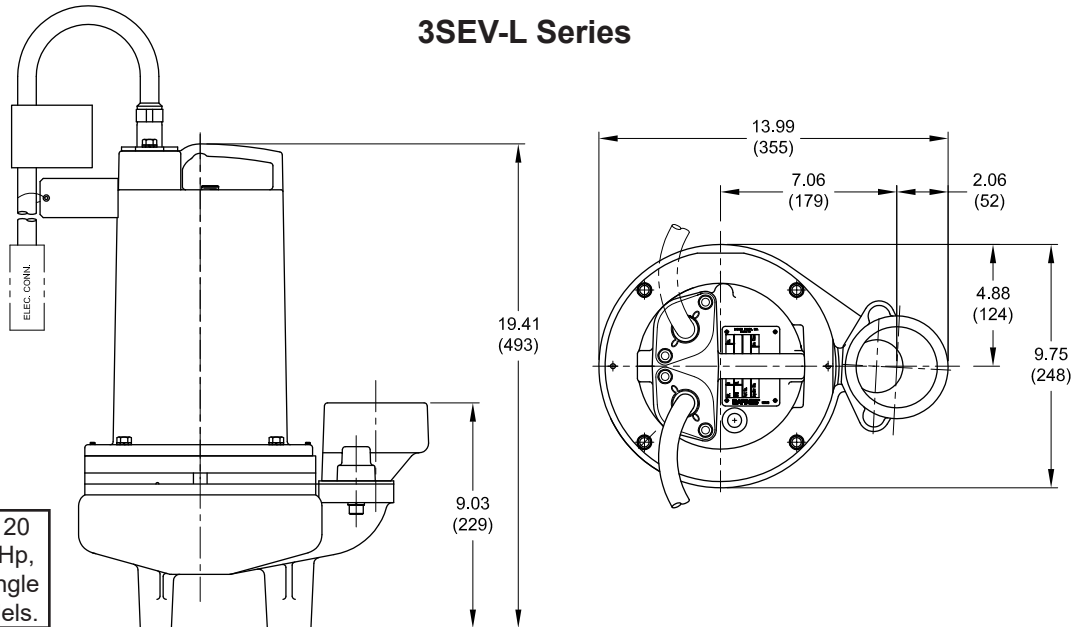

## 3SEV-DS Series

Plugs for 120  
Volt and .5Hp,  
240 Volt Single  
Phase Models.

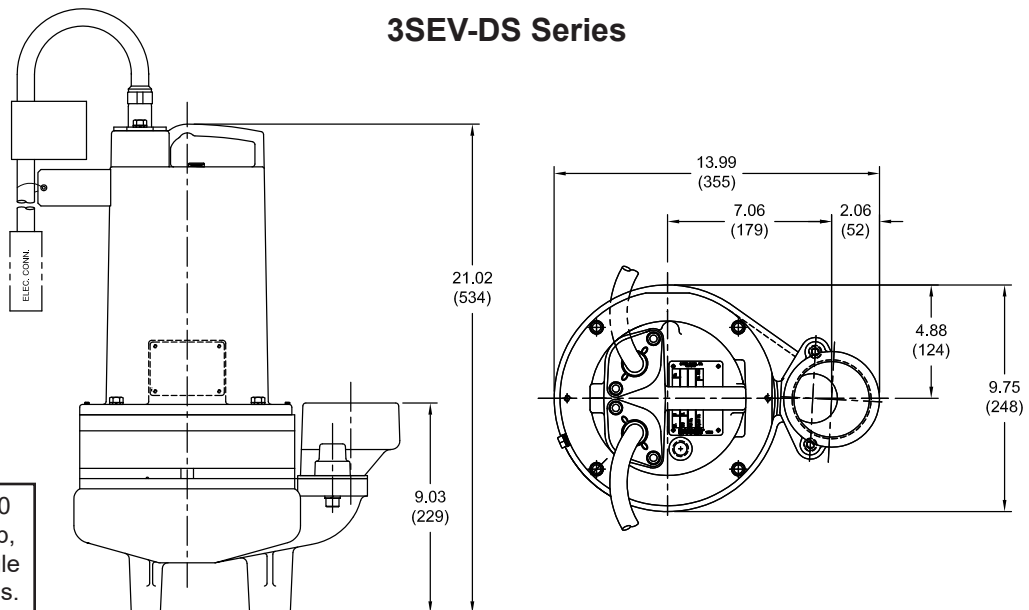

## SECTION B: GENERAL INFORMATION

### B-1) To the Purchaser:

Congratulations! You are the owner of one of the finest pumps on the market today. CP&S pumps are products engineered and manufactured of high quality components. Over one hundred years of pump building experience along with a continuing quality assurance program combine to produce a pump which will stand up to the toughest applications. This manual will provide helpful information concerning installation, maintenance, and proper service guidelines.

### B-2) Receiving:

Upon receiving the pump, it should be inspected for damage or shortages. If damage has occurred, file a claim immediately with the company that delivered the pump. If the manual is removed from the packaging, do not lose or misplace.

### B-3) Storage:

**Short Term-** CP&S Pumps are manufactured for efficient performance following short inoperative periods in storage. For best results, pumps can be retained in storage, as factory assembled, in a dry atmosphere with constant temperatures for up to six (6) months. **Long Term-** Any length of time exceeding six (6) months, but not more than twenty-four (24) months. The unit should be stored in a temperature controlled area, a roofed over walled enclosure that provides protection from the elements (rain, snow, wind-blown dust, etc.), and whose temperature can be maintained between +40 deg. F and +120 deg. F. (4.4 - 49°C). Pump should be stored in its original shipping container. On initial start up, rotate impeller by hand to assure seal and impeller rotate freely. If it is required that the pump be installed and tested before the long term storage begins, such installation will be allowed provided:

- 1.) The pump is not installed under water for more than one (1) month.
- 2.) Immediately upon satisfactory completion of the test, the pump is removed, thoroughly dried, repacked in the original shipping container, and placed in a temperature controlled storage area.

### B-4) Service Centers:

For the location of the nearest Barnes Service Center, check your Barnes representative or Crane Pumps & Systems, Inc., Service Department in Piqua, Ohio, telephone (937) 778-8947 or Crane Pumps & Systems Canada, in Brampton, Ontario, (905) 457-6223.

## SECTION C: INSTALLATION

### C-1) Location:

These pumping units are self-contained and are recommended for use in a sump, lift station or basin that is free of hard debris, like gravel, stones, sand, or earth. The sump, lift station or basin shall be vented in accordance with local plumbing codes. This pump is designed to pump sewage, effluent, or other nonexplosive or noncorrosive wastewater. and shall **NOT** be installed in locations classified as hazardous in accordance with the National Electrical Code (NEC), ANSI/NFPA 70 or the Canadian Electrical Code (CEC). Never install the pump in a trench, ditch or hole with gravel, stones, sand, or earth bottom; the legs will sink into the dirt and the suction will become plugged, or the pump impeller will be damaged.

### C-1.1) Submergence:

It is recommended that the pump be operated in the submerged condition and the sump liquid level should never be lower than the top of the pump (see Fig 2).

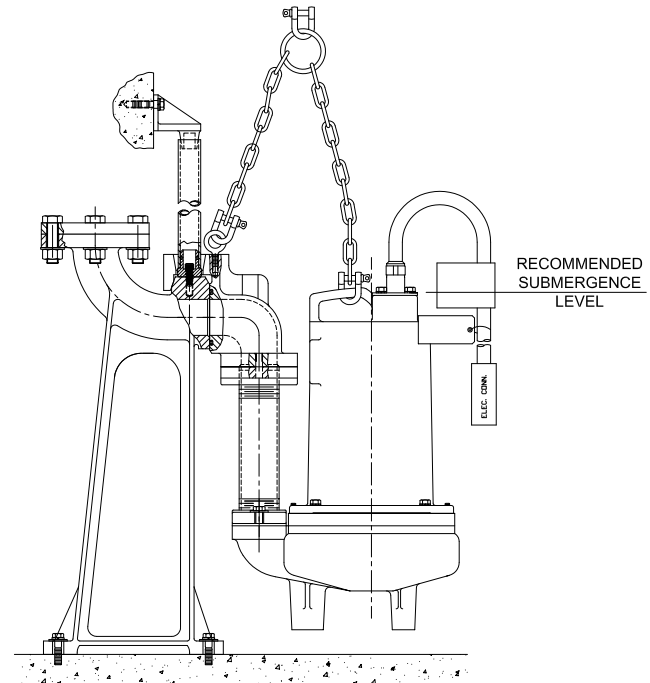

FIGURE 1

### C-2) Discharge:

Discharge piping should be as short as possible. Both a check valve and a shut-off valve are recommended for each pump being used. The check valve is used to prevent backflow into the sump. Excessive backflow can cause flooding and/or damage to the pump. The shut-off valve is used to stop system flow during pump or check valve servicing.

Barnes Pumps supplies a Stainless Rail Package for the 2" models and also a variety of 2" and 3" break away fitting discharge systems (see Fig. 1) designed to allow the submersible wastewater pump to be installed or removed without requiring personnel to enter the wet well. Contact your local Barnes Pumps distributor for complete details.

**Stainless Rail Package (Not Shown)** - The package system comes complete and ready to place into the ground as outlined in the project specifications. The moveable portion of the Break Away Fitting (BAF), check valve, piping and guide bracket comes assembled on the pump along with the lifting cord. Insert pump bracket and moveable portion of BAF into the guide channel and lower pump into basin (**DO NOT DROP**). Now connect power and control cords to the junction box or control panel depending on system design.

### C-3) Liquid Level Controls:

The level controls are to be supported by a mounting bracket that is attached to the sump wall, cover or junction box. Cord grips are used to hold the cords in place on the mounting bracket. The control level can be changed by loosening the grip and adjusting the cord length as per the plans and specifications. Be certain that the level controls cannot hang up or foul in it's swing and that the pump is completely submerged when the level control is in the "Off" mode.

## TYPICAL INSTALLATION WITH WIDE ANGLE LEVEL CONTROL

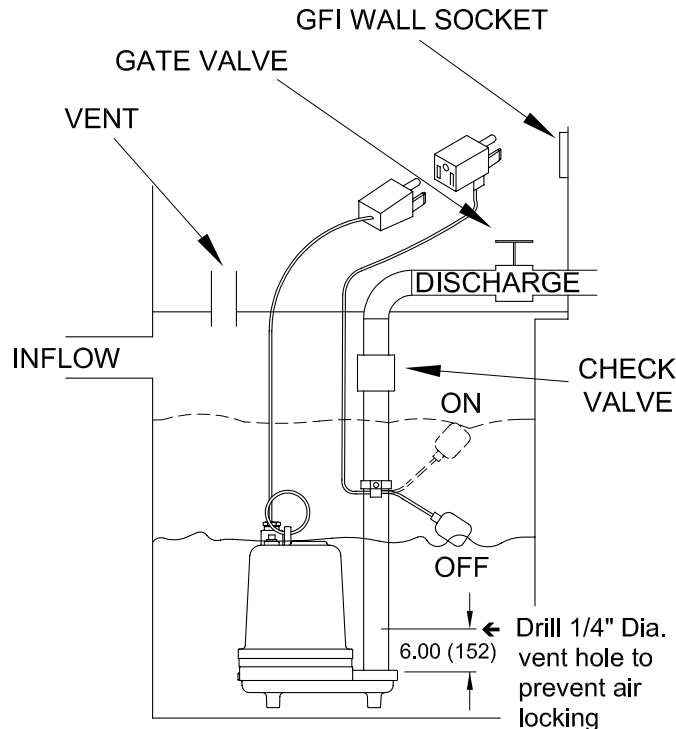

FIGURE 2

Figure 2 shows a typical installation for 1 phase 120 and 240 volt pump with piggy-back plug for manual and automatic operation.

### General Comments:

- 1) Never work in the sump with the power on.
- 2) Level controls are factory set for a pumping differential of 9 inches. If that is the cycle desired, simply circle the discharge pipe with the pipe mounting strap, feed the end through the worm drive, and tighten with a screwdriver. Be certain that the level control cannot hang up or foul in it's swing. Also, make certain the top of the pump is still submerged when the level control is in the 'off' mode.
- 3) If a higher pump differential is needed, grip the cord near the neck of the float, then using the other hand, exert a steady force on the lower edge of the cable clamp. The cable clamp should slide up to the new pivot point. Attach the level control to the discharge hose in the manner described above.
- 4) Plug the level control plug into the receptacle, then plug the pump into the piggyback plug. One cycle of operation should be observed, so that any potential problems can be corrected.
- 5) It is recommended that the float should be set to insure that the sump well liquid level never drops below the top of the motor housing.
- 6.) Figure 3 shows a typical connection for pumps with the wide angle float and piggy-back plug. For manual and automatic operations.

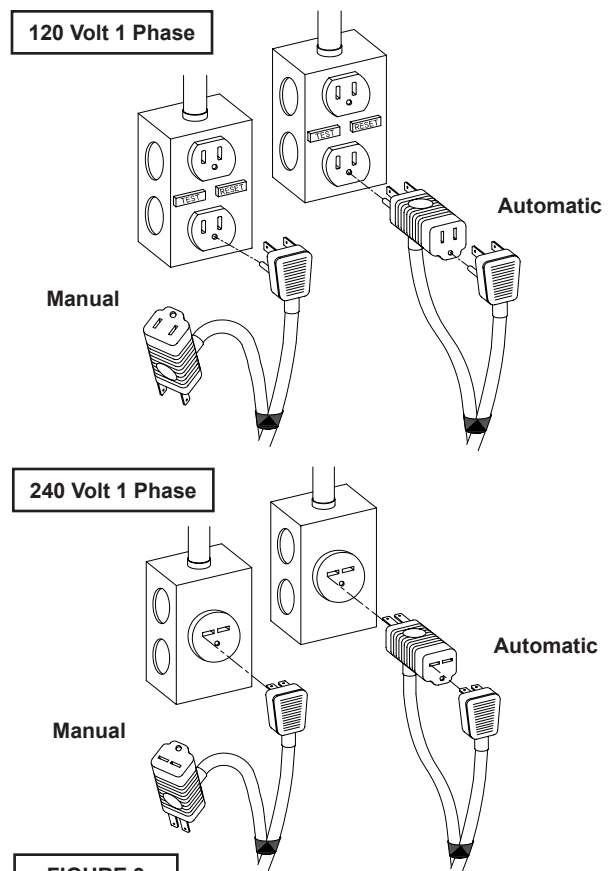

FIGURE 3

- Automatic -** Plug float cord into outlet, then plug pump cord into float cord.
- Manual -** Plug pump cord directly into outlet.

### C-4) Electrical Connections:

#### C-4.1) Power and Control Cords:

The cord assembly mounted to the pump must not be modified in any way except for shortening to a specific application. Any splice between the pump and the control panel must be made in accordance with all applicable electric codes. It is recommended that a junction box, if used, be mounted outside the sump or be of at least Nema 4 (EEMAC-4) construction if located within the wet well. **DO NOT USE THE POWER OR CONTROL CORD TO LIFT PUMP. NOTE: THE WHITE WIRE IS NOT A NEUTRAL OR GROUND LEAD, BUT A POWER CARRYING CONDUCTOR.**

#### C-4.2) Overload Protection:

**C-4.2-1) Three Phase (Optional)** - The normally closed (N/C) thermal sensor is embedded in the motor windings and will detect excessive heat in the event an overload condition occurs. The thermal sensor will trip when the windings become too hot and will automatically reset itself when the pump motor cools to a safe temperature. It is recommended that the thermal sensor be connected in series to an alarm device to alert the operator of an overload condition, and/or the motor starter coil to stop the pump. In the event of an overload, the source of this condition should be determined and rectified immediately. **DO NOT LET THE PUMP CYCLE OR RUN IF AN OVERLOAD CONDITION OCCURS !**

MODEL NO	PART NO	HP	VOLT/PH	Hz	RPM (Nom)	NEMA START CODE	INSUL. CLASS	FULL LOAD AMPS	LOCKED ROTOR AMPS	CORD SIZE	CORD TYPE	CORD O.D inch (mm)	WINDING RESISTANCE		
													Emerson Main-Start	Franklin Main-Start	G.E. Main-Start
2SEV514L	104918	0.5	120/1	60	1750	F	B	12.0	21.3	14/3	SJTOW	0.375 (9.5)			1.51-16.10
2SEV524L	104919	0.5	240/1	60	1750	J	B	6.3	14.9	14/3	SOW	0.530 (13.5)	3.38-9.30		5.69-18.74
2SEV594L	104920	0.5	200-240/3	60	1750	H/L	B	3.7/3.8	9.8/11.0	14/4	SOW	0.570 (14.5)	10.20	13.00	
2SEV544L	104921	0.5	480/3	60	1750	K	B	1.9	5.3	14/4	SOW	0.570 (14.5)	40.80	52.00	
2SEV554L	104922	0.5	600/3	60	1750	H	B	1.4	3.4	14/4	SOW	0.570 (14.5)		77.60	89.76
2SEV724L	104928	0.75	240/1	60	1750	K	F	7.1	25.8	14/3	SOW	0.530 (13.5)	1.86-10.20		2.74-10.56
2SEV794L	104929	0.75	200-240/3	60	1750	H/K	F	4.8/4.6	13.7/15.4	14/4	SOW	0.570 (14.5)		5.49	6.28
2SEV744L	104930	0.75	480/3	60	1750	K	F	2.3	7.7	14/4	SOW	0.570 (14.5)		21.96	24.51
2SEV754L	104931	0.75	600/3	60	1750	L	B	1.6	7.2	14/4	SOW	0.570 (14.5)		34.36	36.60
2SEV1024L	104936	1.0	240/1	60	1750	G	F	8.5	25.8	14/3	SOW	0.530 (13.5)	1.86-10.20		2.74-10.56
2SEV1094L	104937	1.0	200-240/3	60	1750	E/H	F	5.3/5.1	13.7/15.4	14/3	SOW	0.570 (14.5)		5.49	6.28
2SEV1044L	104938	1.0	480/3	60	1750	H	F	2.5	7.7	14/4	SOW	0.570 (14.5)		21.96	24.51
2SEV1054L	104939	1.0	600/3	60	1750	J	B	2.2	7.2	14/4	SOW	0.570 (14.5)		34.36	36.60
2SEV512L*	104970	0.5	120/1	60	3450	G	B	12.6	24.6	14/3	SJTOW	0.375 (9.5)	1.04-7.20	1.47-9.59	
2SEV522L	104971	0.5	240/1	60	3450	E	B	6.0	10.2	14/3	SOW	0.530 (13.5)		5.08-9.00	10.10-10.16
2SEV592L	104972	0.5	200-240/3	60	3450	P/R	B	5.8/5.3	19.9/18.4	14/4	SOW	0.570 (14.5)		5.50	6.30
2SEV542L	104974	0.5	480/3	60	3450	R	B	2.6	9.1	14/4	SOW	0.570 (14.5)		22.00	25.18
2SEV552L	104975	0.5	600/3	60	3450	T	B	2.1	8.7	14/4	SOW	0.570 (14.5)	21.20		34.57
2SEV1022L	104982	1.0	240/1	60	3450	F	B	10.7	21.8	14/3	SOW	0.530 (13.5)		2.37-6.44	3.04-15.49
2SEV1092L	104983	1.0	200-240/3	60	3450	H/J	B	7.9/7.5	19.9/18.4	14/3	SOW	0.570 (14.5)		5.50	6.30
2SEV1042L	104985	1.0	480/3	60	3450	J	B	3.7	9.1	14/4	SOW	0.570 (14.5)		22.00	25.18
2SEV1052L	104986	1.0	600/3	60	3450	L	B	2.9	8.7	14/4	SOW	0.570 (14.5)	21.20		34.57
2SEV514DS	104923	0.5	120/1	60	1750	F	B	12.0	21.3	14/3	SJTOW	0.375 (9.5)			1.51-16.10
2SEV524DS	104924	0.5	240/1	60	1750	J	B	6.3	14.9	14/3	SOW	0.530 (13.5)	3.38-9.30		5.69-18.74
2SEV594DS	104925	0.5	200-240/3	60	1750	H/L	B	3.7/3.8	9.8/11.0	14/4	SOW	0.570 (14.5)	10.20	13.00	
2SEV544DS	104926	0.5	480/3	60	1750	K	B	1.9	5.3	14/4	SOW	0.570 (14.5)	40.80	52.00	
2SEV554DS	104927	0.5	600/3	60	1750	H	B	1.4	3.4	14/4	SOW	0.570 (14.5)		77.60	89.76
2SEV724DS	104932	0.75	240/1	60	1750	K	F	7.1	25.8	14/3	SOW	0.530 (13.5)	1.86-10.20		2.74-10.56
2SEV794DS	104933	0.75	200-240/3	60	1750	H/K	F	4.8/4.6	13.7/15.4	14/4	SOW	0.570 (14.5)		5.49	6.28
2SEV744DS	104934	0.75	480/3	60	1750	K	F	2.3	7.7	14/4	SOW	0.570 (14.5)		21.96	24.51
2SEV754DS	104935	0.75	600/3	60	1750	L	F	1.6	7.2	14/4	SOW	0.570 (14.5)		34.36	36.60
2SEV1024DS	104940	1.0	240/1	60	1750	G	F	8.5	25.8	14/3	SOW	0.530 (13.5)	1.86-10.20		2.74-10.56
2SEV1094DS	104941	1.0	200-240/3	60	1750	E/H	B	5.3/5.1	13.7/15.4	14/3	SOW	0.570 (14.5)		5.49	6.28
2SEV1044DS	104942	1.0	480/3	60	1750	H	B	2.5	7.7	14/4	SOW	0.570 (14.5)		21.96	24.51
2SEV1054DS	104943	1.0	600/3	60	1750	J	B	2.2	7.2	14/4	SOW	0.570 (14.5)		34.36	36.60
2SEV512DS*	104976	0.5	120/1	60	3450	G	B	12.6	24.6	14/3	SJTOW	0.375 (9.5)	1.04-7.20	1.47-9.59	
2SEV522DS	104977	0.5	240/1	60	3450	E	B	6.0	10.2	14/3	SOW	0.530 (13.5)		5.08-9.00	10.10-10.16
2SEV592DS	104978	0.5	200/240/3	60	3450	P/R	B	5.8/5.3	19.9/18.4	14/3	SOW	0.570 (14.5)		5.50	6.30
2SEV542DS	104980	0.5	480/3	60	3450	R	B	2.6	9.1	14/3	SOW	0.570 (14.5)		22.00	25.18
2SEV552DS	104981	0.5	600/3	60	3450	T	B	2.1	8.7	14/3	SOW	0.570 (14.5)	21.20		34.57
2SEV1022DS	104987	1.0	240/1	60	3450	F	B	10.7	21.8	14/3	SOW	0.530 (13.5)		2.37-6.44	3.04-15.49
2SEV1092DS	104988	1.0	200-240/3	60	3450	H/J	B	7.9/7.5	19.9/18.4	14/4	SOW	0.570 (14.5)		5.50	6.30
2SEV1042DS	104990	1.0	480/3	60	3450	J	B	3.7	9.1	14/4	SOW	0.570 (14.5)		22.00	25.18
2SEV1052DS	104991	1.0	600/3	60	3450	L	B	2.9	8.7	14/4	SOW	0.570 (14.5)	21.20		34.57

OPTIONAL - Temperature sensor cord for 3 phase models is 14/3 SOW, 0.530 (13.5mm) O.D.

OPTIONAL - Moisture sensor cord is 18/5 SOW, 0.470 (11.9mm) O.D.

OPTIONAL - Moisture & Temperature sensor cord for 3 phase models is 18/5 SOW, 0.470 (11.9mm) O.D.

(\*) Pump is CSA listed **ONLY**.

MODEL NO	PART NO	HP	VOLT/PH	Hz	RPM (Nom)	NEMA START CODE	INSUL. CLASS	FULL LOAD AMPS	LOCKED ROTOR AMPS	CORD SIZE	CORD TYPE	CORD O.D inch (mm)	WINDING RESISTANCE		
													Emerson Main-Start	Franklin Main-Start	G.E. Main-Start
3SEV514L	104944	0.5	120/1	60	1750	F	B	12.0	21.3	14/3	SJTOW	0.375 (9.5)			1.51-16.10
3SEV524L	104945	0.5	240/1	60	1750	J	B	6.3	14.9	14/3	SOW	0.530 (13.5)	3.38-9.30		5.69-18.74
3SEV594L	104946	0.5	200-240/3	60	1750	H/L	B	3.7/3.8	9.8/11.0	14/4	SOW	0.570 (14.5)	10.20	13.00	
3SEV544L	104947	0.5	480/3	60	1750	K	B	1.9	5.3	14/4	SOW	0.570 (14.5)	40.80	52.00	
3SEV554L	104948	0.5	600/3	60	1750	H	B	1.4	3.4	14/4	SOW	0.570 (14.5)		77.60	89.76
3SEV724L	104954	0.75	240/1	60	1750	K	F	7.1	25.8	14/3	SOW	0.530 (13.5)	1.86-10.20		2.74-10.56
3SEV794L	104955	0.75	200-240/3	60	1750	H/K	F	4.8/4.6	13.7/15.4	14/4	SOW	0.570 (14.5)		5.49	6.28
3SEV744L	104956	0.75	480/3	60	1750	K	F	2.3	7.7	14/4	SOW	0.570 (14.5)		21.96	24.51
3SEV754L	104957	0.75	600/3	60	1750	L	B	1.6	7.2	14/4	SOW	0.570 (14.5)		34.36	36.60
3SEV1024L	104962	1.0	240/1	60	1750	G	F	8.5	25.8	14/3	SOW	0.530 (13.5)	1.86-10.20		2.74-10.56
3SEV1094L	104963	1.0	200-240/3	60	1750	E/H	F	5.3/5.1	13.7/15.4	14/3	SOW	0.570 (14.5)		5.49	6.28
3SEV1044L	104964	1.0	480/3	60	1750	H	F	2.5	7.7	14/4	SOW	0.570 (14.5)		21.96	24.51
3SEV1054L	104965	1.0	600/3	60	1750	J	B	2.2	7.2	14/4	SOW	0.570 (14.5)		34.36	36.60
3SEV512L*	104992	0.5	120/1	60	3450	G	B	12.6	24.6	14/3	SJTOW	0.375 (9.5)	1.04-7.20	1.47-9.59	
3SEV522L	104993	0.5	240/1	60	3450	E	B	6.0	10.2	14/3	SOW	0.530 (13.5)		5.08-9.00	10.10-10.16
3SEV592L	104994	0.5	200-240/3	60	3450	P/R	B	5.8/5.3	19.9/18.4	14/4	SOW	0.570 (14.5)		5.50	6.30
3SEV542L	104996	0.5	480/3	60	3450	R	B	2.6	9.1	14/4	SOW	0.570 (14.5)		22.00	25.18
3SEV552L	104997	0.5	600/3	60	3450	T	B	2.1	8.7	14/4	SOW	0.570 (14.5)	21.20		34.57
3SEV1022L	105004	1.0	240/1	60	3450	F	B	10.7	21.8	14/3	SOW	0.530 (13.5)		2.37-6.44	3.04-15.49
3SEV1092L	105005	1.0	200-240/3	60	3450	H/J	B	7.9/7.5	19.9/18.4	14/3	SOW	0.570 (14.5)		5.50	6.30
3SEV1042L	105007	1.0	480/3	60	3450	J	B	3.7	9.1	14/4	SOW	0.570 (14.5)		22.00	25.18
3SEV1052L	105008	1.0	600/3	60	3450	L	B	2.9	8.7	14/4	SOW	0.570 (14.5)	21.20		34.57
3SEV514DS	104949	0.5	120/1	60	1750	F	B	12.0	21.3	14/3	SJTOW	0.375 (9.5)			1.51-16.10
3SEV524DS	104950	0.5	240/1	60	1750	J	B	6.3	14.9	14/3	SOW	0.530 (13.5)	3.38-9.30		5.69-18.74
3SEV594DS	104951	0.5	200-240/3	60	1750	H/L	B	3.7/3.8	9.8/11.0	14/4	SOW	0.570 (14.5)	10.20	13.00	
3SEV544DS	104952	0.5	480/3	60	1750	K	B	1.9	5.3	14/4	SOW	0.570 (14.5)	40.80	52.00	
3SEV554DS	104953	0.5	600/3	60	1750	H	B	1.4	3.4	14/4	SOW	0.570 (14.5)		77.60	89.76
3SEV724DS	104958	0.75	240/1	60	1750	K	F	7.1	25.8	14/3	SOW	0.530 (13.5)	1.86-10.20		2.74-10.56
3SEV794DS	104959	0.75	200-240/3	60	1750	H/K	F	4.8/4.6	13.7/15.4	14/4	SOW	0.570 (14.5)		5.49	6.28
3SEV744DS	104960	0.75	480/3	60	1750	K	F	2.3	7.7	14/4	SOW	0.570 (14.5)		21.96	24.51
3SEV754DS	104961	0.75	600/3	60	1750	L	B	1.6	7.2	14/4	SOW	0.570 (14.5)		34.36	36.60
3SEV1024DS	104966	1.0	240/1	60	1750	G	F	8.5	25.8	14/3	SOW	0.530 (13.5)	1.86-10.20		2.74-10.56
3SEV1094DS	104967	1.0	200-240/3	60	1750	E/H	F	5.3/5.1	13.7/15.4	14/3	SOW	0.570 (14.5)		5.49	6.28
3SEV1044DS	104968	1.0	480/3	60	1750	H	F	2.5	7.7	14/4	SOW	0.570 (14.5)		21.96	24.51
3SEV1054DS	104969	1.0	600/3	60	1750	J	B	2.2	7.2	14/4	SOW	0.570 (14.5)		34.36	36.60
3SEV512DS*	104998	0.5	120/1	60	3450	G	B	12.6	24.6	14/3	SJTOW	0.375 (9.5)	1.04-7.20	1.47-9.59	
3SEV522DS	104999	0.5	240/1	60	3450	E	B	6.0	10.2	14/3	SOW	0.530 (13.5)		5.08-9.00	10.10-10.16
3SEV592DS	105000	0.5	200/240/3	60	3450	P/R	B	5.8/5.3	19.9/18.4	14/3	SOW	0.570 (14.5)		5.50	6.30
3SEV542DS	105002	0.5	480/3	60	3450	R	B	2.6	9.1	14/3	SOW	0.570 (14.5)		22.00	25.18
3SEV552DS	105003	0.5	600/3	60	3450	T	B	2.1	8.7	14/3	SOW	0.570 (14.5)	21.20		34.57
3SEV1022DS	105009	1.0	240/1	60	3450	F	B	10.7	21.8	14/3	SOW	0.530 (13.5)		2.37-6.44	3.04-15.49
3SEV1092DS	105010	1.0	200-240/3	60	3450	H/J	B	7.9/7.5	19.9/18.4	14/4	SOW	0.570 (14.5)		5.50	6.30
3SEV1042DS	105012	1.0	480/3	60	3450	J	B	3.7	9.1	14/4	SOW	0.570 (14.5)		22.00	25.18
3SEV1052DS	105013	1.0	600/3	60	3450	L	B	2.9	8.7	14/4	SOW	0.570 (14.5)	21.20		34.57

OPTIONAL - Temperature sensor cord for 3 phase models is 14/3 SOW, 0.530 (13.5mm) O.D.

OPTIONAL - Moisture sensor cord is 18/5 SOW, 0.470 (11.9mm) O.D.

OPTIONAL - Moisture & Temperature sensor cord for 3 phase models is 18/5 SOW, 0.470 (11.9mm) O.D.

(\*) Pump is CSA listed **ONLY**.

If current through the temperature sensor exceeds the values listed, an intermediate control circuit relay must be used to reduce the current or the sensor will not work properly.

TEMPERATURE SENSOR ELECTRICAL RATINGS		
Volts	Continuous Amperes	Inrush Amperes
110-120	3.00	30.0
220-240	1.50	15.0
440-480	0.75	7.5
600	0.60	6.0

**C-4.2-2) Single Phase (Standard)** - The type of in-winding overload protector used is referred to as an inherent overheating protector and operates on the combined effect of temperature and current. This means that the overload protector will trip out and shut the pump off if the windings become too hot, or the load current passing through them becomes too high. It will then automatically reset and start the pump up after the motor cools to a safe temperature. In the event of an overload, the source of this condition should be determined and rectified immediately. **DO NOT LET THE PUMP CYCLE OR RUN IF AN OVERLOAD CONDITION OCCURS !**

**C-4.3) Moisture Sensors- DS Models: (Optional)**  
 A normally open (N/O) detector is installed in the pump seal chamber which will detect any moisture present. It is recommended that this detector be connected in series to an alarm device or the motor started coil to alert the operator that a moisture detect has occurred. In the event of a moisture detect, check the individual moisture sensor probe leads for continuity, ( $\infty$  resistance = no moisture) and the junction box/control box for moisture content. The above situations may induce a false signal in the moisture detecting circuit. If none of the above tests prove conclusive, the pump(s) should be pulled and the source of the failure identified and repaired. **IF A MOISTURE DETECT HAS OCCURRED SCHEDULE MAINTENANCE AS SOON AS POSSIBLE.**

**C-4.4) Wire Size:**  
 Consult a qualified electrician for proper wire size if additional power cord length is required. See table on pages 8 and 9 for electrical information.

## SECTION: D START-UP OPERATION

**D-1) Check Voltage and Phase:**  
 Before operating pump, compare the voltage and phase information stamped on the pump identification plate to the available power.

**D-2) Check Pump Rotation:**  
 Before putting pump into service for the first time, the motor rotation must be checked. Improper motor rotation can result in poor pump performance and can damage the motor and/or pump. To check the rotation, suspend the pump freely, momentarily apply power and observe the “kickback”. “Kickback” should always be in a counter-clockwise direction as viewed from the top of the pump motor housing.

**D-2.1) Incorrect Rotation for Three-Phase Pumps:**  
 In the event that the rotation is incorrect for a three-phase installation, interchange any two power cord leads at the control box. **DO NOT** change leads in the cord housing in the motor. Recheck the “kickback” rotation again by momentarily applying power.

**D-2.2) Incorrect Rotation for Single-Phase Pumps:**  
 In the unlikely event that the rotation is incorrect for a single phase pump, contact a Barnes Pumps Service Center.

**D-3) Identification Plate:**  
 Record future serial plate information in the “NOTES” section.

**D-3.1) Insulation Test:**  
 Before the pump is put into service, an insulation (megger) test should be performed on the motor. The resistance values (ohms) as well as the voltage (volts) and current (amps) should be recorded on the start-up report.

**D-3.1) Pump-Down Test:**  
 After the pump has been properly wired and lowered into the basin, sump or lift station, it is advisable to check the system by filling with liquid and allowing the pump to operate through its pumping cycle. The time needed to empty the system, or pump-down time along with the volume of water, should be recorded on the start-up report.

## SECTION E: PREVENTATIVE MAINTENANCE

As the motor is oil filled, no lubrication or other maintenance is required, and generally Barnes Pumps will give very reliable service and can be expected to operate for years on normal sewage pumping without failing. In our experience attempts at preventative maintenance are more likely to reduce, rather than extend the life of our pumps. However, if you are inclined to perform preventative maintenance, the following are the steps that should be performed.

- 1) Inspect motor chamber for oil level and contamination and repair as required per section F-1.
- 2) Inspect impeller and body for excessive build-up or clogging and repair as required per section F-2.
- 3) Inspect motor and bearings and replace as required per section F-3.
- 4) Inspect seal for wear or leakage and repair as required per section F-4.

## SECTION F: SERVICE AND REPAIR

**NOTE:** All item numbers in ( ) refer to Figures 16 thru 19.



**CAUTION ! - Operating pump builds up heat and pressure; allow time for pump to cool to room temperature before handling or servicing. Slowly remove pipe plug prior to servicing as housing may be pressurized.**

### F-1) Lubrication:

Anytime the pump is removed from operation, the cooling oil in the motor housing (6) should be checked visually for oil level and contamination.

#### F-1.1) Checking Oil:

**Motor Housing** - To check oil, set unit upright. Remove pipe plug (39) from motor housing (6). With a flashlight, visually inspect the oil in the motor housing (6) to make sure it is clean and clear, light amber in color and free from suspended particles. Milky white oil indicates the presence of water. Oil level should be just above the motor when pump is in vertical position.

#### F-1.2) Testing Oil:

- 1.) Place pump on it's side, remove pipe plug (39), from motor housing (6) and drain oil into a clean, dry container.
- 2.) Check oil for contamination using an oil tester with a range to 30 Kilovolts breakdown.
- 3.) If oil is found to be clean and uncontaminated (measuring above 15 KV. breakdown), refill the motor housing as per section F-1.4.
- 4.) If oil is found to be dirty or contaminated (or measures below 15 KV. breakdown), the pump must be carefully inspected for leaks at the shaft seal (28), cord assemblies (16) and (56 if used), square ring (27) and pipe plug (39), before refilling with oil. To locate the leak, perform a pressure test as per section F-1.3. After leak is repaired, dispose of old oil properly, and refill with new oil as per section F-1.4.

#### F-1.3) Pressure Test:

PRESSURE GAUGE ASSY  
(SEE PARTS LIST)

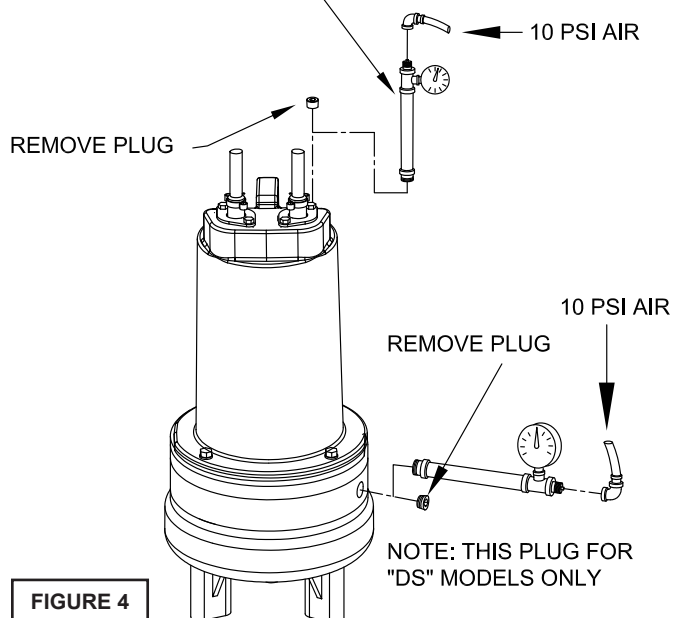

FIGURE 4

**Pumps that have had the oil drained from the Motor Housing** - Apply pipe sealant to pressure gauge assembly and tighten into pipe plug hole (See Figure 3). Pressurize motor housing to 10 P.S.I. Use soap solution around the sealed areas and inspect joints for "air bubbles". If, after five minutes, the pressure is still holding constant, and no "bubbles" are observed, slowly bleed the pressure and remove the gauge assembly. Replace oil as described in section F-1.4. If the pressure does not hold, then the leak must be located and repaired.

**Pumps that have NOT had the oil drained from the Motor Housing** - The pressure test may be done with the oil at its normal level. Remove pipe plug (39) from motor housing (6). Apply pipe sealant to pressure gauge assembly and tighten into hole (See Figure 3). Pressurize motor housing to 10 P.S.I. Use soap solution around the sealed areas above the oil level and inspect joints for "air bubbles".

For sealed areas below the oil level, leaks will seep oil. If, after five minutes, the pressure is still holding constant, and no "bubbles"/oil seepage is observed, slowly bleed the pressure and remove the gauge assembly. If the pressure does not hold, then the leak must be located and repaired.

**Seal Chamber (DS Units Only)**- Set unit on its side with fill plug (44) downward, remove plug (44) and drain all oil from seal chamber. Apply pipe sealant to pressure gauge assembly and tighten into hole in outer seal plate (29). Pressurize seal chamber to 10 P.S.I. and check for leaks as outlined above.



**CAUTION ! Pressure builds up extremely fast, increase pressure by "tapping" air nozzle. Too much pressure will damage seal. DO NOT exceed 10 P.S.I.**

#### F-1.4) Replacing Oil:

**Motor Housing**- Set unit upright and refill with new cooling oil as per Table 1 (see parts list for amount). Fill to just above motor as an air space must remain in the top of the motor housing to compensate for oil expansion (see Fig. 15 or 17). Apply pipe thread compound to threads of pipe plug (39) then assemble to motor housing (6).



**Important ! - For single phase units, oil level should be below capacitor**

**Seal Chamber (DS Units Only)**- Set unit on its side, with plug (44) upward, and refill with new oil as per Table 1 (see parts list for amount). Apply pipe thread compound to threads of pipe plug (44) and assemble to outer seal plate (29).



**Warning ! - Do not overfill oil. Overfilling of motor housing with oil can create excessive and dangerous hydraulic pressure which can destroy the pump and create a hazard. Overfilling oil voids warranty.**

TABLE 1 - COOLING OIL - Dielectric	
SUPPLIER	GRADE
BP	Enerpar SE100
Conoco	Pale Paraffin 22
Mobile	D.T.E. Oil Light
G & G Oil	Circulating 22
Imperial Oil	Voltesso-35
Shell Canada	Transformer-10
Texaco	Diala-Oil-AX
Woco	Premium 100

**F-2) Impeller and Volute Service:**

**F-2.1) Disassembly and Inspection:**

To clean out volute (1) or replace impeller (33), disconnect power, remove hex bolts (26), and lockwasher (12), vertically lift motor and seal plate assembly from volute (1) and spacer ring (31), see Figure 4. Clean out body if necessary. Clean and examine impeller (33), for pitting or wear and replace if required, inspect gasket (36) and replace if cut or damaged. If the impeller (33) needs replacing, place a flat screwdriver in the slot of the end of the shaft to hold the shaft stationary while unscrewing the jam nut (66) and impeller (33).

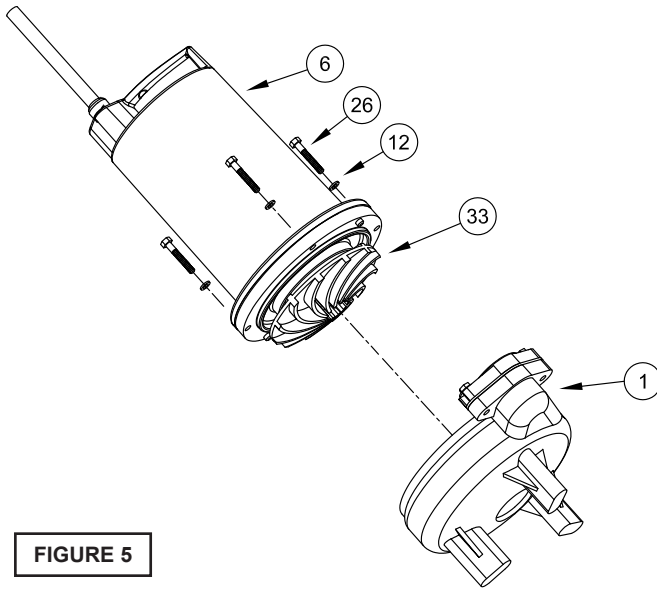

**FIGURE 5**

**F-2.2) Reassembly:**

To install impeller (33), clean the threads with thread locking compound cleaner. Apply removable Loctite® 603 or equivalent to shaft threads. Screw impeller onto the shaft hand tight while using a screwdriver in the slot at the end of the shaft to hold it stationary. Apply thread locking compound (57) to shaft threads then install jam nut (66) and torque to 40 ft. lbs. It is important that the spring of the lower shaft seal (28) seats in the hub of the impeller (33). Rotate impeller to check for binding. Position gasket (36) on volute flange and place spacer ring (31) over it. Place another gasket (36) on spacer ring and position impeller and motor housing on spacer ring (31). Position lockwasher (12) on cap screw (26) and screw into volute (1). Torque to 100 in-lbs. Check for free rotation of motor and impeller.

**F-3) Shaft Seal Service:**

**Important ! - Handle seal parts with extreme care. DO NOT scratch or mar lapped surfaces.**

**F-3.1) Disassembly and Inspection:**

**Outer Seal (All Units) -** To expose shaft seal (28) for examination, disassemble volute and impeller as outlined in paragraph F-2.1. If further repair is required, remove retaining ring (28d), spring (28c) and rotating member (28b) from shaft (see Figures 5 & 6). Examine all seal parts and especially contact faces. Inspect seal for signs of wear such as uneven wear pattern on stationary members, chips and scratches on either seal face. **DO NOT** interchange seal components, replace the entire shaft seal (28). If replacing seal, remove stationary (28a) by prying out with flat screwdriver.

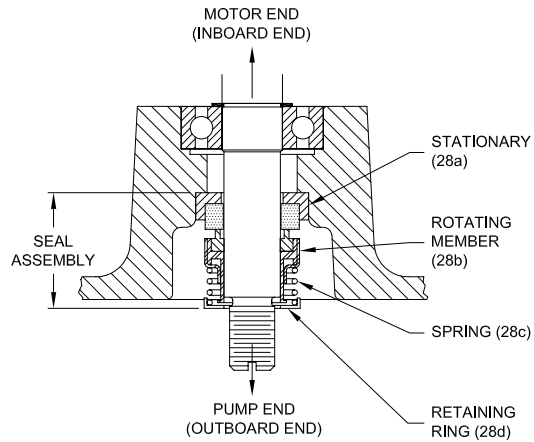

**FIGURE 6 - SINGLE SEAL**

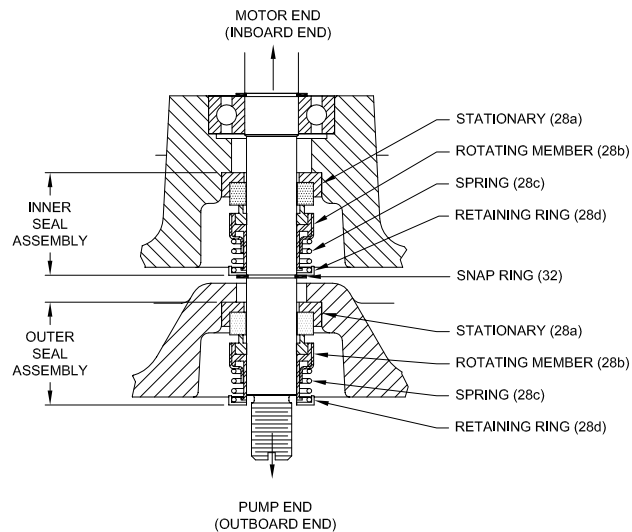

**FIGURE 6 - DOUBLE SEAL**

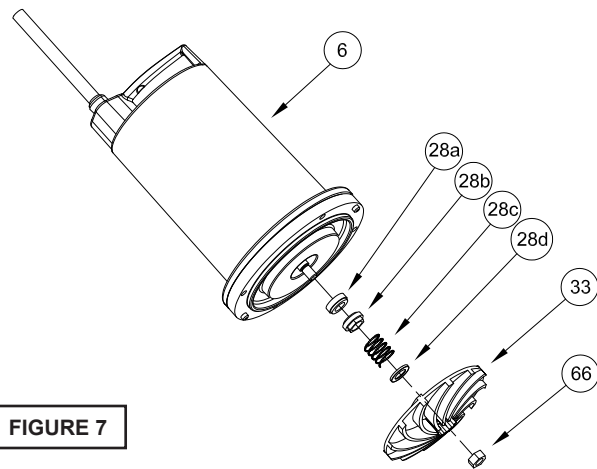

**FIGURE 7**

**Inner Seal (DS Units Only)** - To expose inner shaft seal (28) for examination, remove outer seal as outlined above. Remove socket head cap screws (64). Lift outer seal plate (29) and square-ring (27) from inner seal plate (5). See Figure 7. If further repair is required, remove snap ring (32), retaining ring (28d), spring (28c) and rotating member (28b) from shaft. Examine as outlined in outer seal paragraph. If replacing seal, remove stationary (28a) by prying out with flat screwdriver.

**F-3.2) Reassembly**

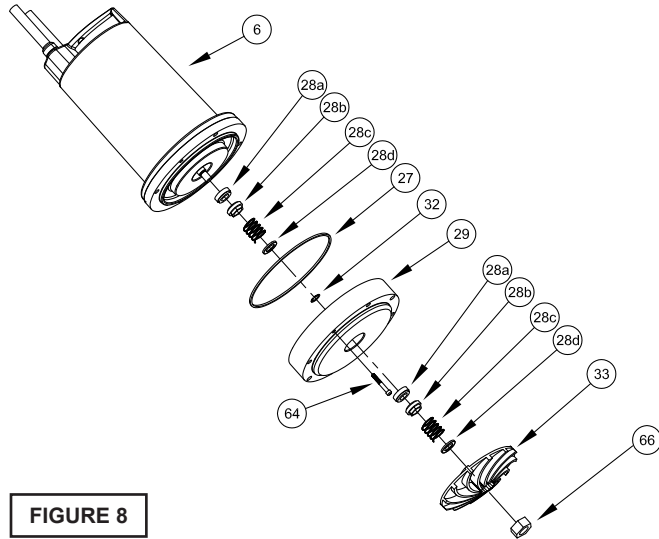
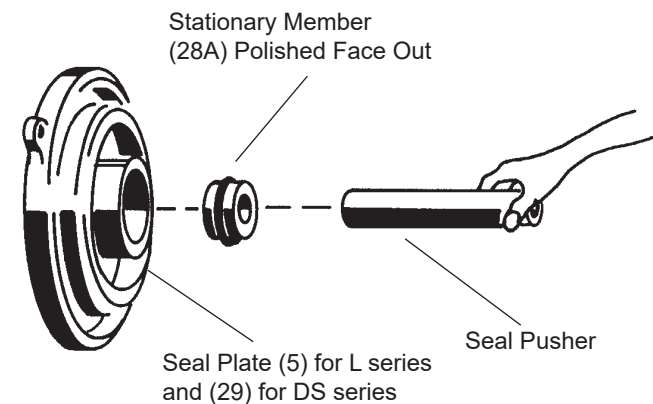

**FIGURE 8**

**Inner Seal (DS Units Only)**- Clean and oil seal cavities in seal plates (5, 29). Lightly oil (**DO NOT** use grease) outer surface of stationary member (28a). Press stationary member (28a) firmly into inner seal plate (5), using a seal pusher (see parts list - seal tool kit). Nothing but the seal pusher is to come in contact with seal face (see Figure 8).

**Important ! - DO NOT hammer on the seal pusher - it will damage the seal face.**

Make sure the stationary member is in straight. Slide a bullet (see parts list - seal tool kit) over motor shaft. Lightly oil (**DO NOT** use grease) shaft, bullet and inner surface of bellows on rotating member (28b), see Figure 9. With lapped surface of rotating member (28b) facing inward toward stationary member, slide rotating member over bullet and onto shaft, using seal pusher, until lapped faces of (28a) and (28b) are together (see Figure 8).



**FIGURE 9**

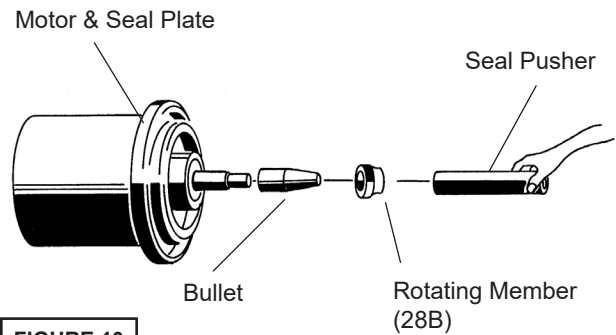

**FIGURE 10**

It is extremely important to keep seal faces clean during assembly. Dirt particles lodged between these faces will cause the seal to leak. Place spring (28c) over shaft and in place on rotating member (28b), making sure it is seated on retainer and not cocked or resting on bellows tail. Slide retaining ring (28d) over shaft and let rest on spring (28c). Replace snap ring (32) in groove of shaft. Set square-ring (27) in groove on outer seal plate (29) and place outer seal plate (29) onto inner seal plate (5). Replace socket head cap screws (64) and torque to 60 in-lbs.

**Outer Seal (All Units)** - Press stationary member (28a) firmly into outer seal plate (5, or 29 on DS Units) as described above. Slide rotating member (28b) onto stationary member using seal pusher as described above. Place spring (28c) and retaining ring (28d) onto rotating member (28b). Assemble impeller and volute as outlined in paragraph F-2.2. Replace oil as outlined in paragraph F-1.4.

**F-4) Motor and Bearing Service:**

**F-4.1) Disassembly and Inspection:**

To examine or replace the motor (7), capacitor (9, single phase units), controls (56, optional), and bearing (25), drain oil from motor as outlined in paragraph F-1.1. Disassemble volute and impeller as outlined in paragraph F-2.1 and disassemble shaft seal as outlined in paragraph F-3.1

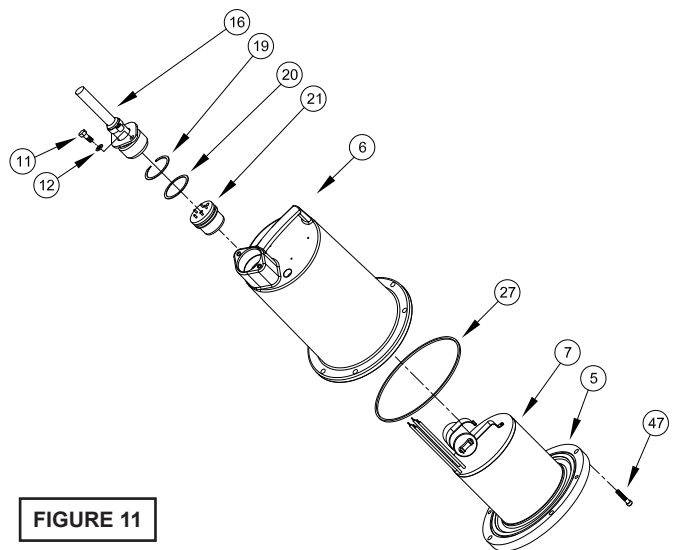

**FIGURE 11**

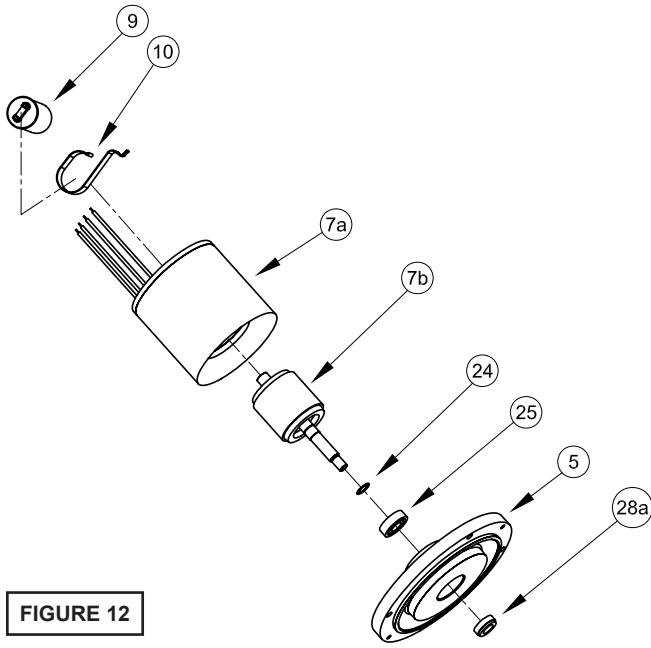

**FIGURE 12**

Position unit upright, using blocks to avoid resting unit on shaft. Unscrew cord hex bolts (11) and remove compression flange (16a) and power cord (16). Remove snap ring (19) with a flat head screwdriver. Pull the terminal block (21) out of the housing (6) using a T-bolt or a pair of pliers and a .25-20 screw in the threads of the terminal block (21). Be sure to leave slack on the motor leads connected underneath. Use needle nose pliers to pull each female connector off of the pins on the underside of the terminal block (21), see Figure 10. The unit voltage should be noted.

Repeat cord and terminal block removal procedure for any control cords (56) if equipped. Remove socket head screws (47). Vertically lift the motor housing (6) from seal plate (5) by lifting handle (13). Inspect square ring (27) for damage or cuts. Remove the motor bolts and lift motor stator from seal plate (5). Disconnect capacitor leads from capacitor (9, single phase units). Examine bearing (25) and replace if required. If replacement is required, remove bearing (25) from motor shaft using a wheel puller or arbor press, see Figure 11.

Check motor capacitor (9, single phase units) with an Ohm meter by first grounding the capacitor by placing a screwdriver across both terminals and then removing screwdriver. Connect Ohm meter (set on high scale) to terminals. If needle moves to infinity (∞) then drifts back, the capacitor is good. If needle does not move or moves to infinity (∞) and does not drift back, replace capacitor (9).

If moisture sensors (4, optional) are damaged, disconnect leads by removing machine screws (45) and washers (46) from probes (4). Remove probes (4) from seal plate (5). To test the temperature sensor (50, optional), check for continuity between the black and white wires. If found to be defective, contact a motor service station or Barnes Pumps Service department. Inspect motor winding for shorts and check resistance values. Check rotor for wear. If rotor or the stator windings are defective, the complete motor must be replaced.



**Important ! - All parts must be clean before reassembly.**

**F-4.2) Reassembly:**

**Moisture Sensors, DS Models** - If pump is equipped with optional moisture sensors, reassemble by applying thread compound to threads on probes (4) and install in upper seal plate (5), see Figures 17 and 18. Connect wire assemblies (53) to probes (4) with washers (46) and machine screws (45).

**Thermal Sensors**- If pump is equipped with optional thermal sensors use terminal connectors (52) to connect wire assemblies (51) to sensor leads. If found to be defective, contact a motor service station or Barnes Pumps Service department.

**Bearings**- When replacing bearing, be careful not to damage the rotor or shaft threads. Clean the shaft thoroughly. Press bearing (25) on the motor shaft, position squarely onto the shaft applying force to the inner race of the bearing only, until bearing seats against the retaining ring (24) (Included with motor).

**Motor**- Slide lower bearing (25) and motor shaft squarely into the seal plate (5) until bearing seats on the bottom. Place stator over rotor, lining up motor bolts with holes in seal plate (5). Position capacitor (9, single phase units) so that it will lay on the opposite side of the cord entry bosses of the motor housing (6). Reconnect capacitor leads. Torque motor tie bolts to 17 in-lbs. Set square ring (27) in groove on seal plate (5).

**F-4.3) Wiring Connections:**

Check power cords (16) and control cord (56, if used), for cracks or damage and replace if required (see Figure 12). Make internal wiring connections which are independent of the terminal block as shown, using connectors (48) and wire assemblies (49) as required. **Do not** use wire nuts. Slip motor leads and ground wire into fiberglass sleeve. Lower motor housing (6) down onto seal plate (5) while aligning holes and stringing motor leads through the cord entry bore(s). (Slipping cords inside a 1 ft. length of .5" conduit makes this easier). Place socket head cap screws (47) through seal plate (5) into motor housing (6) and torque to 60 in-lbs.

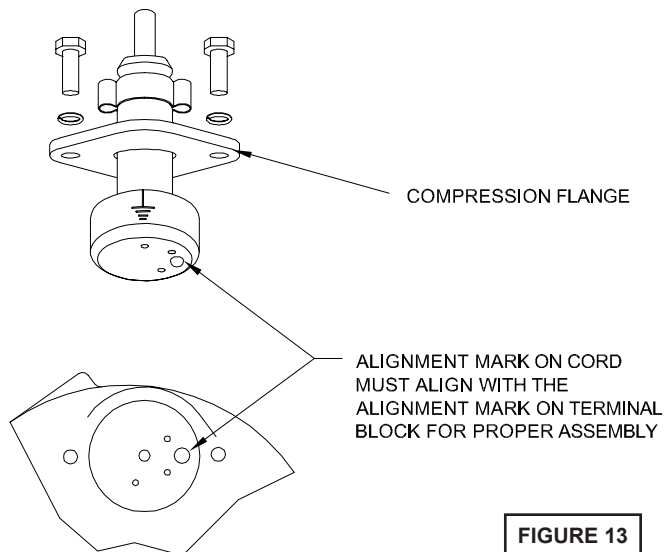

**FIGURE 13**

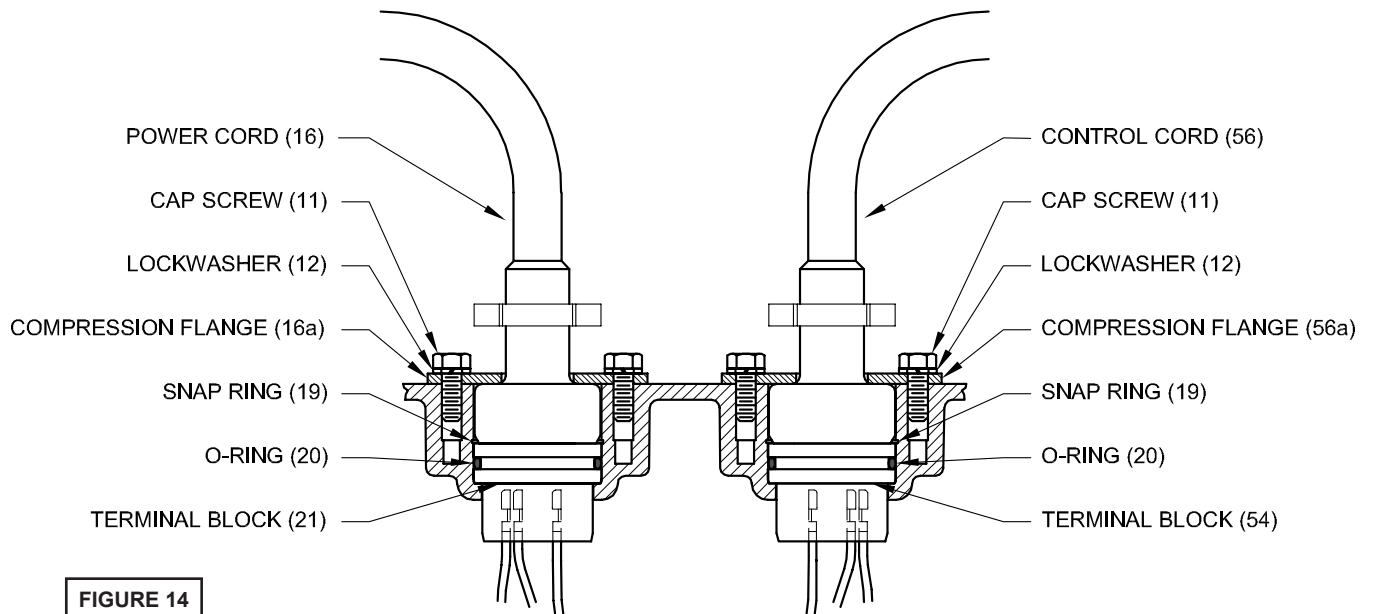

**FIGURE 14**

Reconnect motor and optional control leads to the underside of the terminal block(s) (21), (54 optional) as shown in Figure 14. Note that the pins are numbered underneath the terminal block. Place o-ring (20) into groove in terminal block and lubricate with dielectric oil. Press the terminal block (21) into the housing so it seats completely below the snap ring groove. Place snap ring (19) into groove in cord entry bore of housing. Repeat terminal block installation for control cord, if equipped.

**F-4.4) Cord Assemblies:**

Power/Control Cord - Refill the cooling oil as outlined in paragraph F-1.3. Make wire connections as outlined in paragraph F-4.3. Insert female end of cord plug into housing bore aligning timing mark with hole in terminal block (21), see Figure 13. Compress cord plug with compression flange (16a) by tightening hex bolts (11) into the housing (6). Torque to 132 in-lbs.

**SECTION: G REPLACEMENT PARTS**

**G-1 ORDERING REPLACEMENT PARTS:**

When ordering replacement parts, ALWAYS furnish the following information:

1. Pump serial number and date code. (Paragraph G-4)
2. Pump model number. (Paragraph G-3)
3. Pump part number. (Paragraph G-2)
4. Part description.
5. Item part number.
6. Quantity required.
7. Shipping instructions.
8. Billing Instructions.

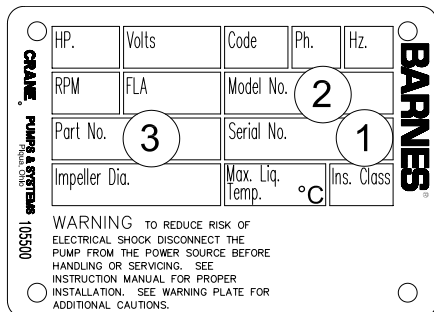

**G-2 PART NUMBER:**

The part number consists of a six (6) digit number, which appears in the catalog. A one or two letter suffix may follow this number to designate the design configuration. This number is used for ordering and obtaining information.

**G-3 MODEL NUMBER:**

This designation consists of numbers and letters which represent the discharge size, series, horsepower, motor phase and voltage, speed and pump design. This number is used for ordering and obtaining information.

**G-4 SERIAL NUMBER:**

The serial number block will consist of a six digit number, which is specific to each pump and may be preceded by a alpha character, which indicates the plant location. This number will also be suffixed with a four digit number, which indicates the date the unit was built (Date Code).

**EXAMPLE: A012345 0490.**

Reference the six digit portion (Serial Number) of this number when referring to the product.

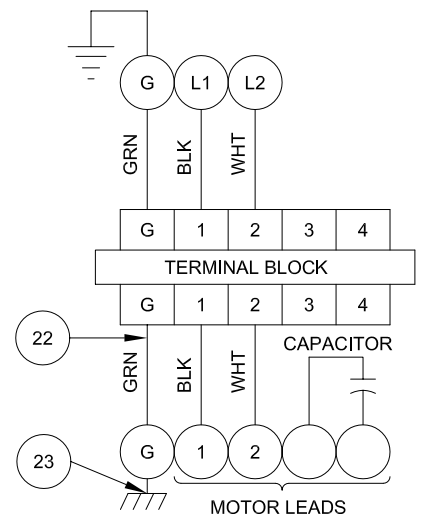

**SINGLE PHASE - 240 VOLT AC (PSC)**

**FIGURE 15**

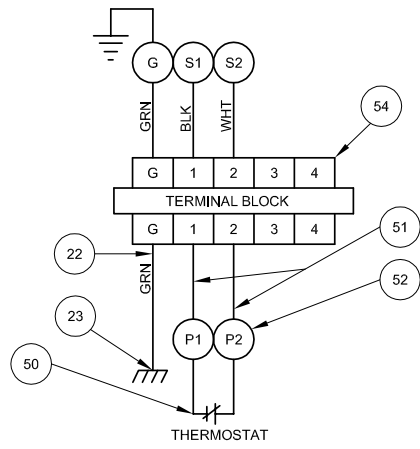
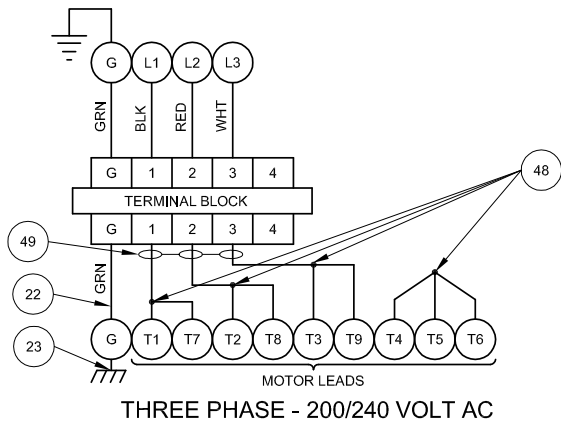

TEMPERATURE SENSORS:  
Three Phase (Optional)

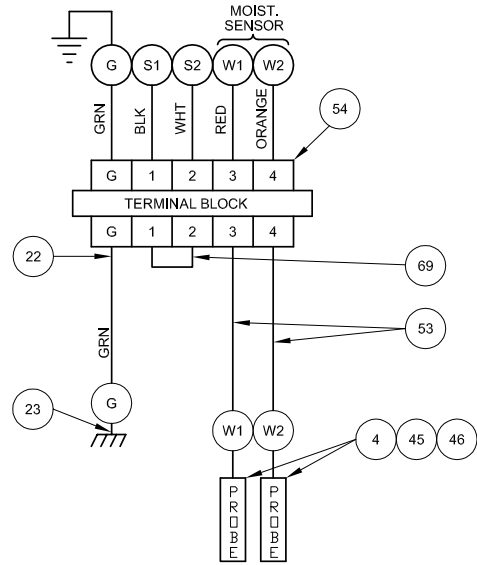
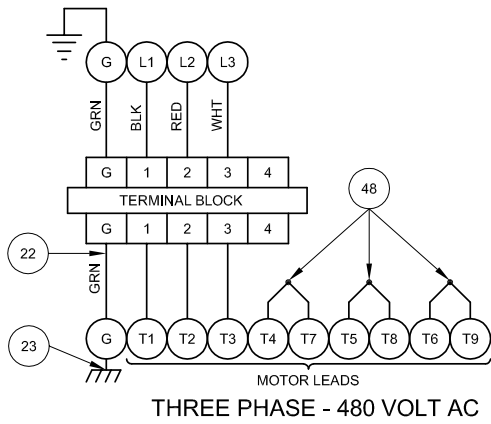

MOISTURE SENSORS  
SINGLE PHASE DS MODELS (Standard)

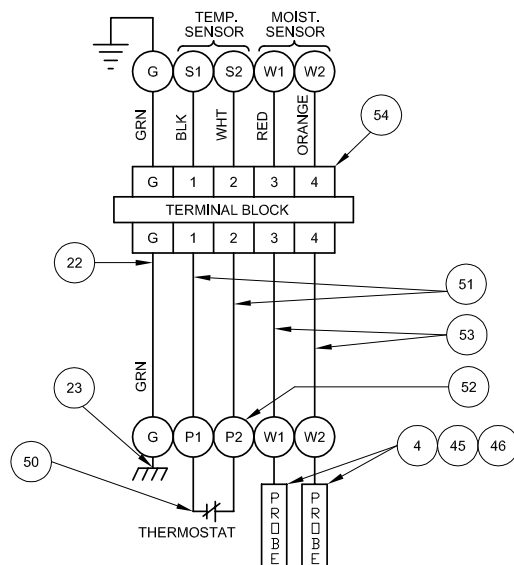
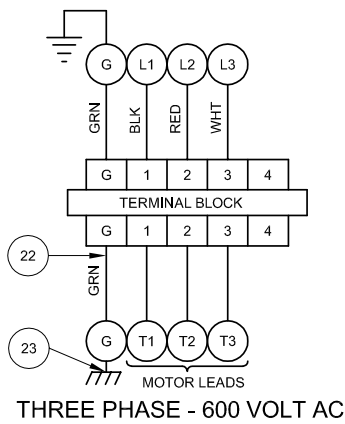

MOISTURE AND TEMPERATURE SENSORS:  
Three Phase DS Models (Standard)

FIGURE 15 - CONTIUED

## TROUBLE SHOOTING

**CAUTION !** Always disconnect the pump from the electrical power source before handling.  
 If the system fails to operate properly, carefully read instructions and perform maintenance recommendations.  
 If operating problems persist, the following chart may be of assistance in identifying and correcting them:  
**MATCH “CAUSE” NUMBER WITH CORRELATING “CORRECTION” NUMBER.**

**NOTE:** Not all problems and corrections will apply to each pump model.

PROBLEM	CAUSE	CORRECTION
Pump will not run	1. Poor electrical connection, blown fuse, tripped breaker or other interruption of power, improper power supply. 2. Motor or switch inoperative (to isolate cause, go to manual operation of pump). 2a. Float movement restricted. 2b. Switch will not activate pump or is defective. 3. Insufficient liquid level.	1. Check all electrical connections for security. Have electrician measure current in motor leads, if current is within $\pm 20\%$ of locked rotor Amps, impeller is probably locked. If current is 0, overload may be tripped. Remove power, allow pump to cool, then recheck current. 2a. Reposition pump or clean basin as required to provide adequate clearance for float. 2b. Disconnect level control. Set ohmmeter for a low range, such as 100 ohms full scale and connect to level control leads. Actuate level control manually and check to see that ohmmeter shows zero ohms for closed switch and full scale for open switch. (Float Switch). 3. Make sure liquid level is at least equal to suggested turn-on point.
Pump will not turn off	2a. Float movement restricted. 2b. Switch will not activate pump or is defective. 4. Excessive inflow or pump not properly sized for application. 9. Pump may be airlocked. 14. H-O-A switch on panel is in “HAND” position	4. Recheck all sizing calculations to determine proper pump size. 5. Check discharge line for restrictions, including ice if line passes through or into cold areas. 6. Remove and examine check valve for proper installation and freedom of operation. 7. Open valve. 8. Check cutter for freedom of operation, security and condition. Clean cutter and inlet of any obstruction. 9. Loosen union slightly to allow trapped air to escape. Verify that turn-off level of switch is set so that the suction is always flooded. Clean vent hole.
Pump hums but does not run	1. Incorrect voltage 8. Cutter jammed or loose on shaft, worn or damaged, inlet plugged.	10. Remove & examine for damage. Replace pump stator if required. 11. Repair fixtures as required to eliminate leakage.
Pump delivers insufficient capacity	1. Incorrect voltage. 4. Excessive inflow or pump not properly sized for application. 5. Discharge restricted. 6. Check valve stuck closed or installed backwards. 7. Shut-off valve closed. 8. Cutter jammed or loose on shaft, worn or damaged, inlet plugged. 9. Pump may be airlocked. 10. Pump stator damaged/torn.	12. Check pump temperature limits & fluid temperature. 13. Replace portion of discharge pipe with flexible connector. 14. Turn to automatic position. 15. Check for leaks around basin inlet and outlets.
Pump cycles too frequently or runs periodically when fixtures are not in use	6. Check valve stuck closed or installed backwards. 11. Fixtures are leaking. 15. Ground water entering basin.	
Pump shuts off and turns on independent of switch, (trips thermal overload protector). <b>CAUTION!</b> Pump may start unexpectedly. Disconnect power supply.	1. Incorrect voltage. 4. Excessive inflow or pump not properly sized for application. 8. Cutter jammed, loose on shaft, worn or damaged, inlet plugged. 12. Excessive water temperature.	
Pump operates noisily or vibrates excessively	4. Operating at too high a pressure. 5. Discharge restricted. 8. Cutter broken. 13. Piping attachments to building structure too rigid or too loose.	

# 2SEV- L & 3SEV- L Series, Single Seal

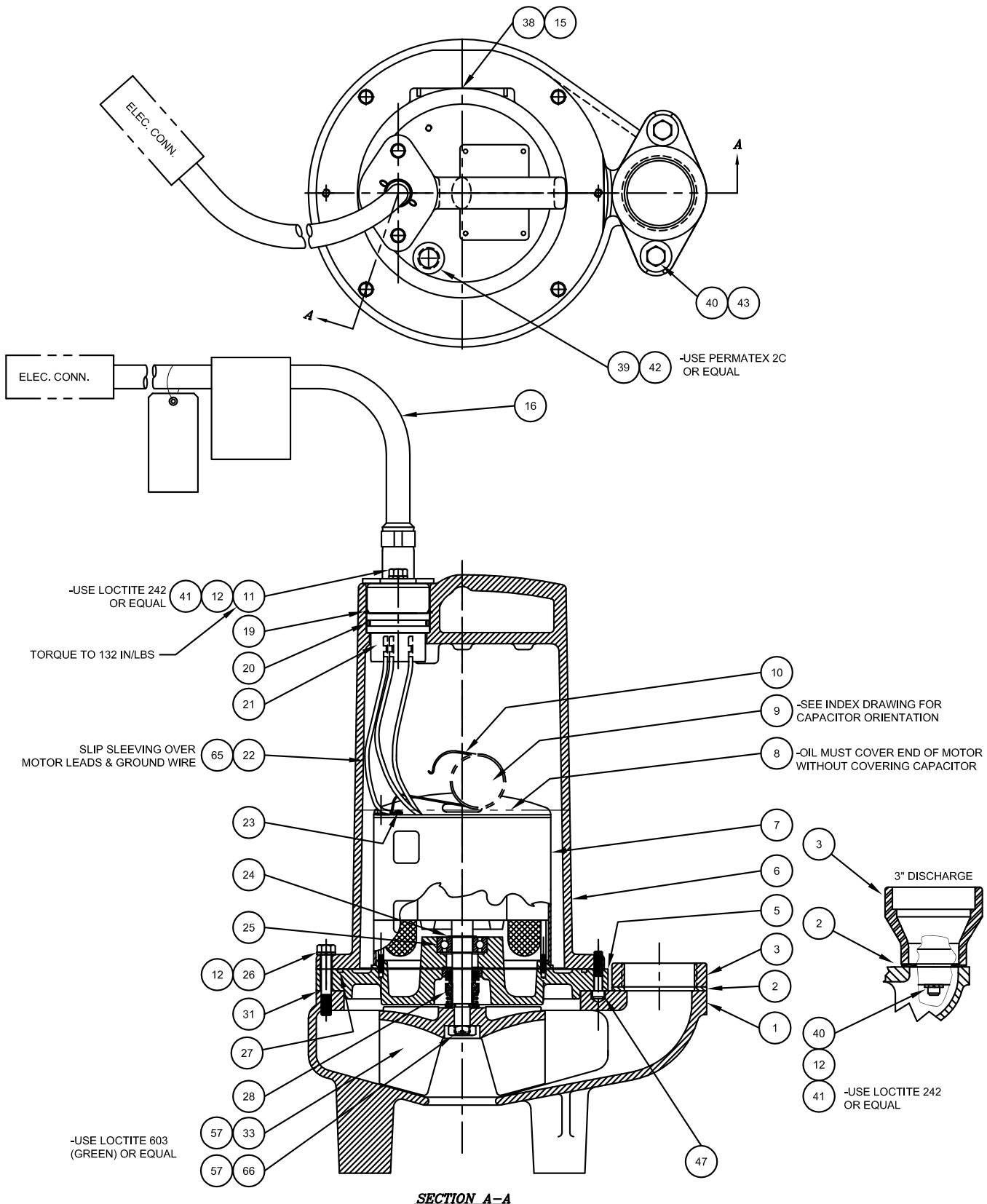

**FIGURE 16**

# 2SEV- L & 3SEV- L Series, Single Seal

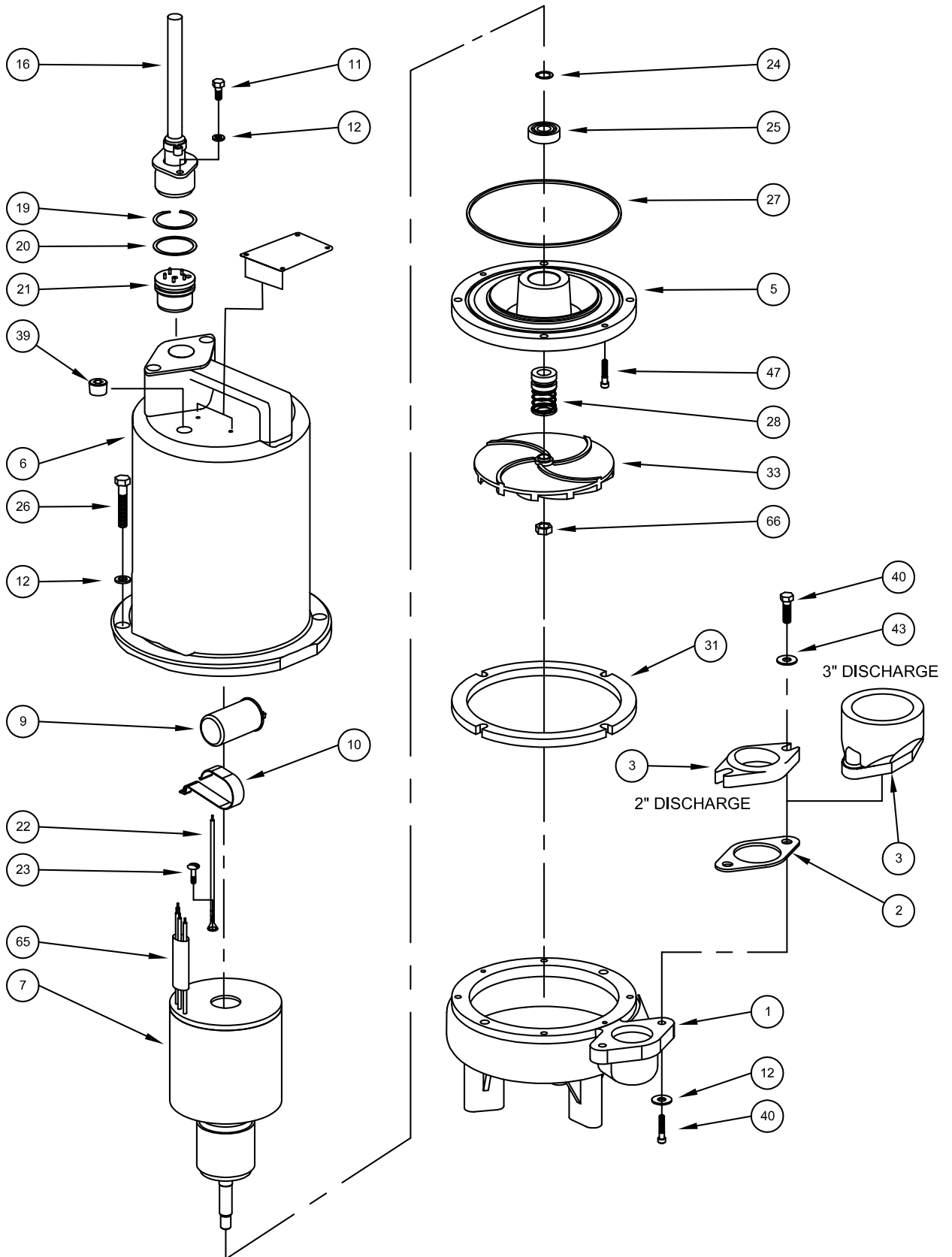
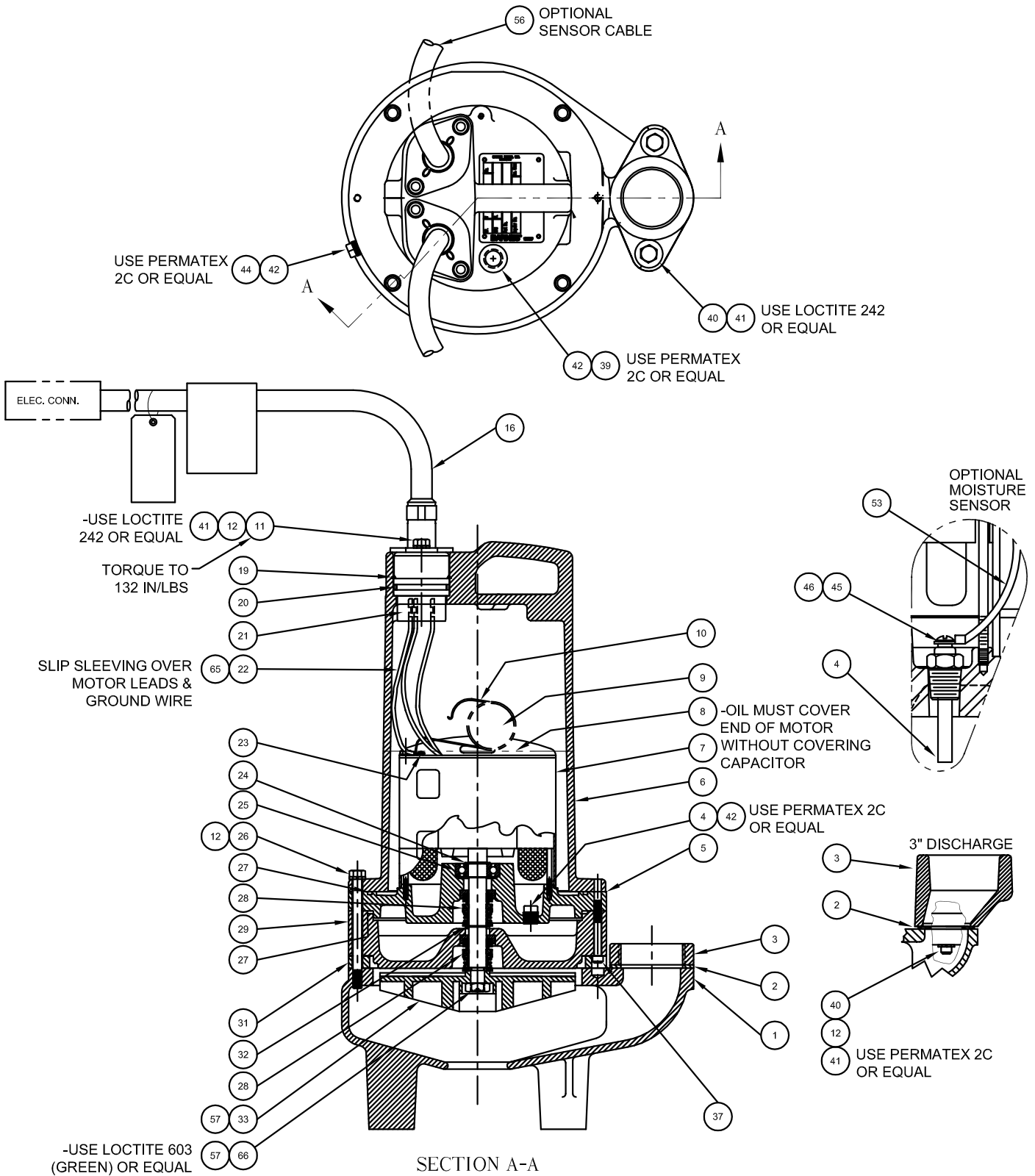

FIGURE 17

# 2SEV- DS & 3SEV- DS Series, Double Seal



**FIGURE 18**

# 2SEV- DS & 3SEV- DS Series, Double Seal

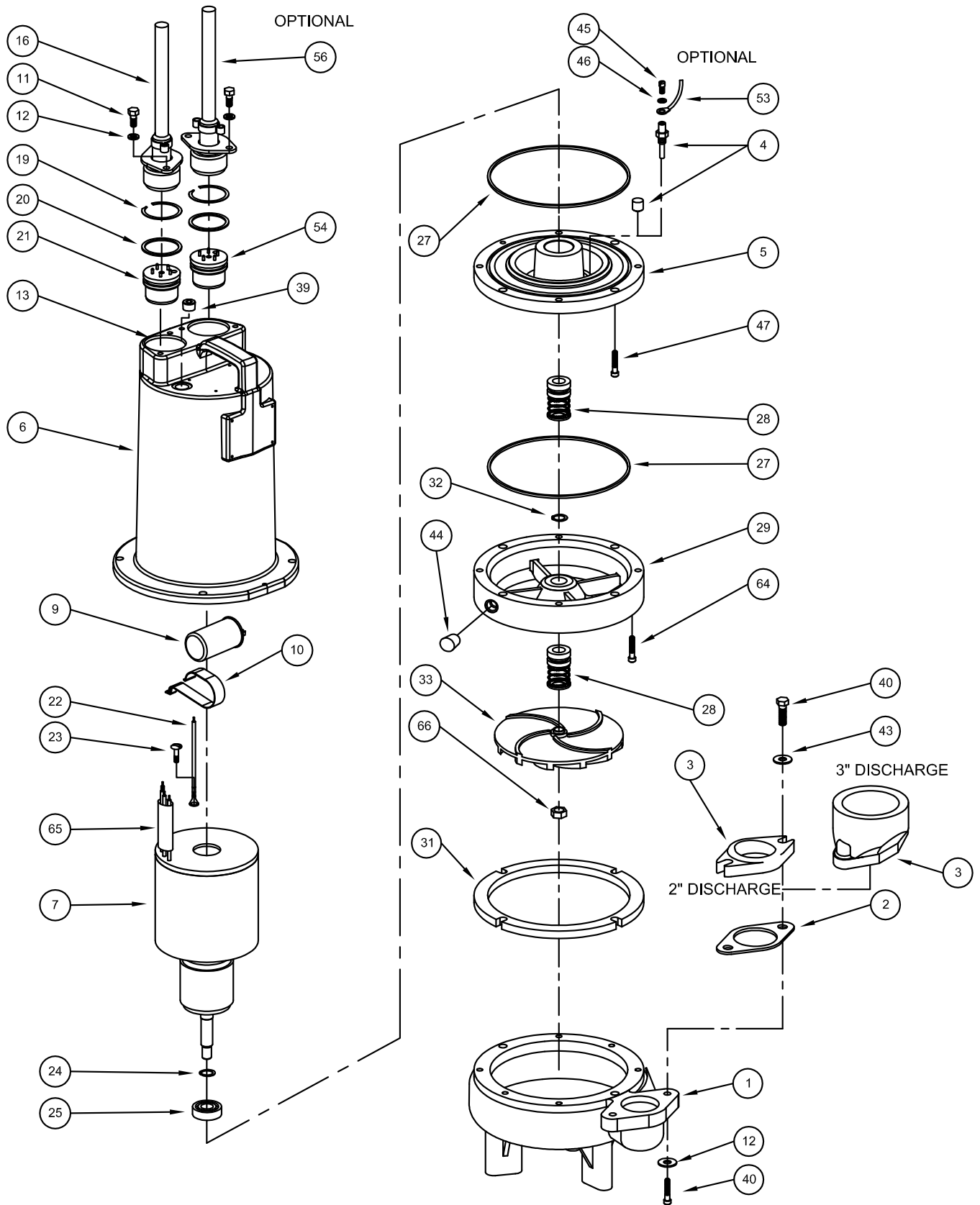

**FIGURE 19**

## PARTS KITS

### Seal Repair Kits:

**Single Seal** .....P/N - **130180** (+) 2, 20, 27, 28, 36

**Double Seal** .....P/N - **130176** (†) 2, 20, 27, 28, 32, 36

### Service Kits:

**Single Seal**.....P/N - **130207** (◇) 2, 19, 20, 22, 24, 25, 27, 28, 36, 49, 65, 66

**Double Seal** .....P/N - **130172** (◆) 2, 19, 20, 22, 24, 25, 27, 28, 32, 36, 44, 49, 65, 66

**Seal Tool Kit** .....P/N - **107271**

**Pressure Gauge Kit** .....P/N - **085343**

## PARTS LIST

ITEM	QTY.	PART NO.	DESCRIPTION	
1	1	055400	Volute	
2	1	069140	+†◇ Gasket	
3	1	026210	Flange, 2" Discharge	
		105153	Flange, 3" Discharge	
4	2	003217	Pipe Plug	All double seal (Std), .25" NPT, ZP
	2	039383	Moisture Sensor Probes	(Optional) for moisture sensor
5	1	084532	Seal Plate	All single seal
		084906		All double seal
6	1	108342A	Motor Housing	(Std)
		110328B		(Optional) for moisture and temp. sensors
7	1		<b>Motor:</b>	
		030369BS	2SEV514L, 3SEV514L	
		030369BD	2SEV514DS, 3SEV514DS	
		030370BS	2SEV524L, 3SEV524L	
		030370BD	2SEV524DS, 3SEV524DS	
		071352BS	2SEV594L, 3SEV594L, 2SEV544L, 3SEV544L	
		071352BD	2SEV594DS, 3SEV594DS, 2SEV544DS, 3SEV544DS	
		092854BS	2SEV554L, 3SEV554L	
		092854BD	2SEV554DS, 3SEV554DS	
		029792BS	2SEV724L, 3SEV724L, 2SEV1024L, 3SEV1024L	
		029792BD	2SEV724DS, 3SEV724DS, 2SEV1024DS, 3SEV1024DS	
		071354BS	2SEV794L, 2SEV744L, 3SEV794L, 3SEV744L, 2SEV1094L, 2SEV1044L, 3SEV1094L, 3SEV1044L	
		071354BD	2SEV794DS, 2SEV744DS, 3SEV794DS, 3SEV744DS, 2SEV1094DS, 2SEV1044DS	
		071354BD	3SEV1094DS, 3SEV1044DS	
		092855BS	2SEV754L, 3SEV754L, 2SEV1054L, 3SEV1054L	
		092855BD	2SEV754DS, 3SEV754DS, 2SEV1054DS, 3SEV1054DS	
		068926BS	2SEV512L, 3SEV512L	
		068926BD	2SEV512DS, 3SEV512DS	
		068927BS	2SEV522L, 3SEV522L	
		068927BD	2SEV522DS, 3SEV522DS	
		068928BS	2SEV1022L, 3SEV1022L	
		068928BD	2SEV1022DS, 3SEV1022DS	
		071355BS	2SEV532L, 2SEV542L, 2SEV562L, 3SEV532L, 3SEV542L, 3SEV562L, 2SEV1032L	
		071355BS	2SEV1042L, 2SEV1062L, 3SEV1032L, 3SEV1042L, 3SEV1062L	
		071355BD	2SEV532DS, 2SEV542DS, 2SEV562DS, 3SEV532DS, 3SEV542DS, 3SEV562DS	
		071355BD	2SEV1032DS, 2SEV1042DS, 2SEV1062DS, 3SEV1032DS, 3SEV1042DS, 3SEV1062DS	
		067463FBS	2SEV552L, 3SEV552L, 2SEV1052L, 3SEV1052L	
		067463FBD	2SEV552DS, 3SEV552DS, 2SEV1052DS, 3SEV1052DS	
8	96oz	029034	Oil	All single seal
	120oz	029034	Oil	All double seal (Includes 24oz. in Seal Chamber)
9	1	034964*	Capacitor	1750RPM, 1 Phase, (30mfd)
		070965	Capacitor	3450 RPM, 1 Phase
10	1	039858	Capacitor Bracket	1 Phase
11	2	1-156-1	Hex. Hd. Cap Screw	(Std), 5/16-18 x 1.00" Lg., Stainless
	6	1-156-1	Hex. Hd. Cap Screw	(Optional) for moisture and temp. sensors
12	8	026322	Lockwasher	(Std), 5/16, Stainless
	12	026322	Lockwasher	(Optional) for moisture and temp. sensors
16	1	See Table 2	Power Cord Set	
19	1	105197	◇ Snap Ring	(Std)
	2	105197	◆ Snap Ring	(Optional) for moisture and temp. sensors

\* Units with build code date (see section G-4) before -0901 may use capacitor part number, 070963 or the 034964 part number.

20	1	2-31051-224	+◇	O-ring	(Std)
	2	2-31051-224	†◆	O-ring	(Optional) for moisture and temp. sensors
21	1	103584		Terminal Block	1 Phase
		103583			3 Phase
22	1	105111	◇◆	Ground Wire Assembly	Std
	2	105111		Ground Wire Assembly	(Optional) for moisture and temp. sensors
23	1	016660		Screw, Self Tapping	#8-32 x .375" Lg., Stainless
24	1	085326	◇◆	Retaining Ring	(Included with motor)
25	1	017414	◇◆	Bearing	
26	4	1-158-1		Cap Screw	All single seal, 5/16-18 x 2.50" Lg., Stainless
		0116491			All double seal
27	1	027269	+†◇◆	Square Ring	All single seal
	2	027269		Square Ring	All double seal
28	1		+†◇◆	<b>Shaft Seal:</b> (Qty 2 for DS)	
		005080		Carbon/Ceramic/Buna-N (STD)	
		005080SB		Tungsten/Tungsten/Buna-N	
		005080SD		Silicon Carbide/Silicon Carbide/Buna-N	
		005080SF		Carbon/Ceramic/Viton	
		005080SH		Tungsten/Tungsten/Viton	
		005080SK		Silicon Carbide/Silicon Carbide/Viton	
		005080SM		Silicon Carbide/Tungsten/Buna-N	
		005080SN		Carbon/Ni-Resistant/Buna-N	
		005080SP		Carbon/Ni-Resistant/Neoprene	
		082850		Carbon/Ni-Resistant/Viton	
29	1	103587		Seal Housing	All double seal
31	1	105145		Spacer Ring	
32	1	2-27008-62	†◆	Retaining Ring	All double seal
33	1			<b>Impeller, Cast Iron, 3450RPM</b>	
		105144TH		4.25 Dia. (STD for a 1.0 HP)	
		105144TJ		4.13 Dia.	
		105144TK		4.00 Dia.	
		105144TL		3.88 Dia.	
		105144TM		3.75 Dia.	
		105144TN		3.63 Dia.	
		105144TP		3.50 Dia. (STD for a .5 HP)	
		105144TQ		3.38 Dia.	
		105144TR		3.25 Dia.	
				<b>Impeller, Cast Iron, 1750RPM</b>	
		105152TB		6.75 Dia. (STD for a 1.0 HP)	
		105152TC		6.63 Dia.	
		105152TD		6.50 Dia.	
		105152TE		6.38 Dia.	
		105152TF		6.25 Dia.	
		105152TG		6.13 Dia.	
		105152TH		6.00 Dia. (STD for a .75 HP)	
		105152TJ		5.88 Dia.	
		105152TK		5.75 Dia.	
		105152TL		5.63 Dia.	
		105152TM		5.50 Dia.	
		105152TN		5.38 Dia. (STD for a .5 HP)	
		105152TP		5.25 Dia.	
		105152TQ		5.13 Dia.	
		105152TR		5.00 Dia.	
39	1	014270		Pipe Plug	.375" NPT, ZP
40	2	1-36-1		Hex. Hd. Cap Screw	2" Discharge, 3/8-16 x 1.25" Lg., Stainless
		2-23030-59		Soc. Hd. Cap Screw	3" Discharge, 5/16-18 x 1.50" Lg., Stainless
41	A/R	-----		Loctite 242	
42	A/R	-----		Permatex 2C	
43	2	082727		Washer	2" Discharge, 3/8" Stainless
44	1	003217	◆	Pipe Plug	All double seal, .25" NPT, ZP
45	2	5-32-6		Screw	(Optional) for moisture sensor, #6-32 x .25" Lg., ZP
46	2	052563		Lockwasher	(Optional) for moisture sensor #6 Stl.
47	2	084948		Socket Head Screw	1/4-20 x 1.25" Lg., Stainless
48	1	See BOM		Terminal Connector	200-240V, 3Ph
	3	See BOM		Terminal Connector	480V, 3PH
49	3	105149	◇◆	Wire Assembly	200-240V, 3Ph

50	1	051621	Thermal Sensor	(Optional) for temperature sensor, (Not Shown)
51	2	105155	Wire Assembly	(Optional) for temperature sensor, (Not Shown)
52	2	134013	Terminal Connector	(Optional) for temperature sensor, (Not Shown)
53	2	105106	Wire Assembly	(Optional) for moisture sensor
54	1	103584	Terminal Block	Temperature sensor options
		113272		Moisture and temp. sensor options
56	1	See Table 2	Control Cord	(Optional) for moisture and/or temp. sensors
56a	1	103582	Compression Flange	Included with Cord Set
57	A/R		Loctite 603	
64	2	030337	Socket Head Cap Screw	Double seal Only, 1/4-20 x 2" Lg., Stainless
65	1	625-02117	◇◆ Sleeve, Fiberglass	
66	1	030068	◇◆ Jam Nut	1/2-20, SS
69	1	111909	Jumper Wire	

**TABLE 2 - POWER & SENSOR CORD SETS**

<b>CABLE LENGTH</b>	<b>ITEM #16 120 VOLT 1 PHASE  (plug included)</b>	<b>ITEM #16 240 VOLT 1 PHASE 0.5HP (plug included)</b>	<b>ITEM #16 240 VOLT 1 PHASE 0.75 &amp; 1HP  (no plug)</b>	<b>ITEM #16 3 PHASE  (no plug)</b>	<b>ITEM #56 (OPTIONAL) Temperature 3 Phase</b>	<b>ITEM #56 (OPTIONAL) Moisture and Temperature Sensor 3 Phase or Moisture Sensor</b>
8 FT	103756A	-----	103741A	103742A	103741A	113288A
15 FT	103756	110949	103741	103742	103741	113288
20 FT <b>(Std)</b>	103756XA	110949XA	103741XA	103742XA	103741XA	113288XA
30 FT <b>(Std)</b>	103756XC	110949XC	103741XC	103742XC	103741XC	113288XC
50 FT	103756XF	110949XF	103741XF	103742XF	103741XF	113288XF
75 FT	103756XJ	110949XJ	103741XJ	103742XJ	103741XJ	113288XJ
100 FT	103756XL	110949XL	103741XL	103742XL	103741XL	113288XL





**IMPORTANT!  
WARRANTY REGISTRATION**

Your product is covered by a warranty:  
[www.cranepumps.com/downloadables/CATALOGS\\_OIPMs/Warranty/24MonthWarranty.pdf](http://www.cranepumps.com/downloadables/CATALOGS_OIPMs/Warranty/24MonthWarranty.pdf)

If you have a claim under the provisions of the warranty, contact your local  
Crane Pumps & Systems, Inc. Distributor.

**RETURNED GOODS**

**RETURN OF MERCHANDISE REQUIRES A "RETURNED GOODS AUTHORIZATION".  
CONTACT YOUR LOCAL CRANE PUMPS & SYSTEMS, INC. DISTRIBUTOR.**



**Products Returned Must Be Cleaned, Sanitized,  
Or Decontaminated As Necessary Prior To Shipment,  
To Insure That Employees Will Not Be Exposed To Health  
Hazards In Handling Said Material. All Applicable Laws  
And Regulations Shall Apply.**