

PRODUCT INFORMATION PACKET



Model No: C145T48FB59D

Catalog No: 120946.00

..2/.5HP..1725/850RPM.145.TEFC.208/230V.3PH.60HZ.CONT.40C.1.0SF.RIGID.C145T48FB59D.....TWO-SPEED.NOT.....

2 Speed



Regal and Leeson are trademarks of Regal Beloit Corporation or one of its affiliated companies.

©2018 Regal Beloit Corporation, All Rights Reserved. MC017097E





Nameplate Specifications

Output HP	2 Hp	Output KW	1.5 kW
Frequency	60 Hz	Voltage	208-230 V
Current	6.4 A	Speed	1725 rpm
Service Factor	1	Phase	3
Efficiency	64 %	Duty	Continuous
Insulation Class	B	Design Code	B
KVA Code	J	Frame	145T
Enclosure	Totally Enclosed Fan Cooled	Overload Protector	No
Ambient Temperature	40 °C	Drive End Bearing Size	6205
Opp Drive End Bearing Size	6203	UL	Recognized
CSA	Y	CE	N
IP Code	43		

Technical Specifications

Electrical Type	Squirrel Cage Induction Run	Starting Method	Across The Line
Poles	4	Rotation	Reversible
Mounting	Rigid base	Motor Orientation	HORIZONTAL
Drive End Bearing	BALL	Opp Drive End Bearing	BALL
Frame Material	Rolled Steel	Shaft Type	T
Overall Length	12.43 in	Frame Length	6.50 in
Shaft Diameter	0.875 in	Shaft Extension	2.25 in
Assembly/Box Mounting	F1 ONLY		
Outline Drawing	028877-650	Connection Diagram	005200.01

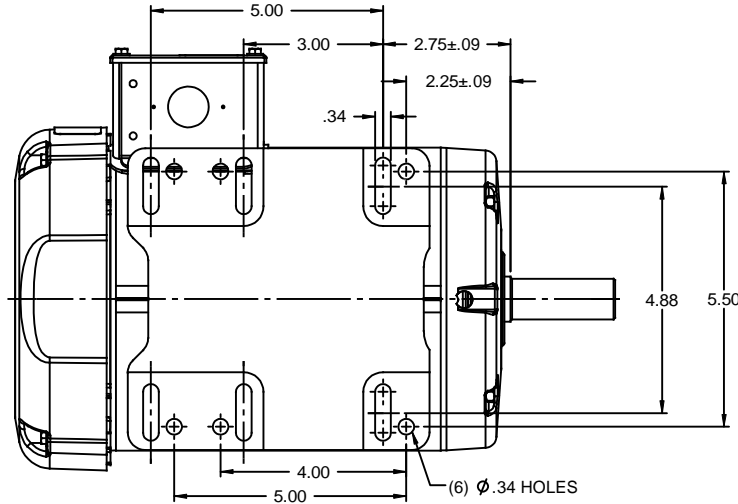
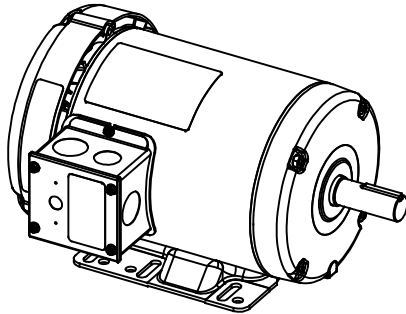
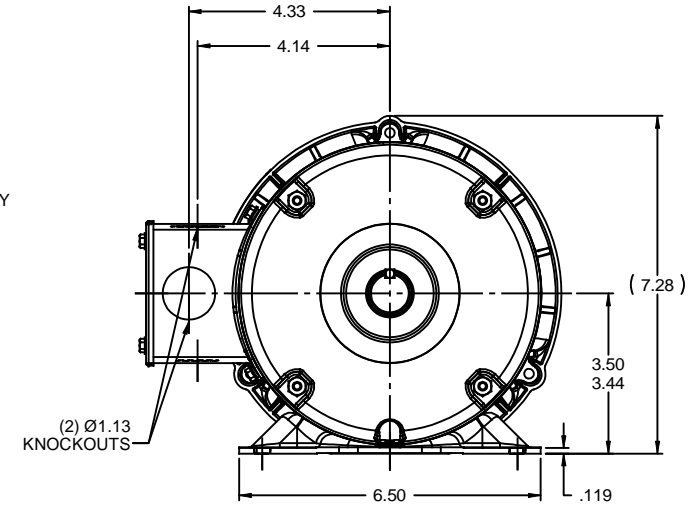
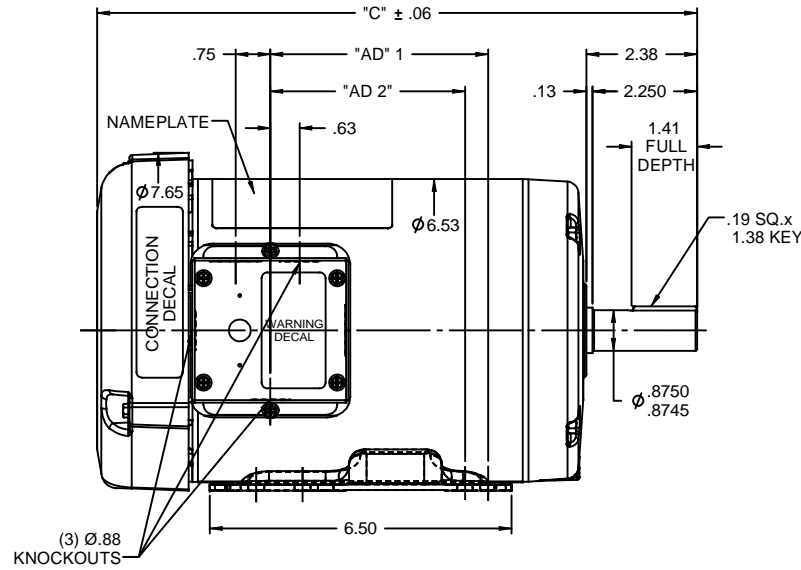
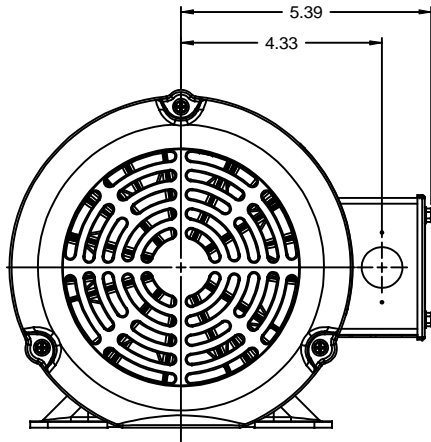

NOTE:
1) GASKETS THROUGHOUT

DASH NO.	"C"	"AD 1"	"AD 2"
600	11.93	3.69	3.19
650	12.43	4.19	3.69
675	12.68	4.44	3.94
700	12.93	4.69	4.19
750	13.43	5.19	4.69
800	13.93	5.69	5.19
850	14.43	6.19	5.69

RBC PROPRIETARY AND CONFIDENTIAL INFORMATION
This document is the property of REGAL BELOIT CORPORATION ("RBC") including its subsidiaries and divisions and contains proprietary information of RBC. This document is loaned on the express condition that neither it nor the information contained therein shall be disclosed to others without the express written consent of RBC and that the information shall be used by the recipient only as approved expressly by RBC. This document shall be returned to RBC upon its request. This document may be subject to certain restrictions under U.S. export control laws and regulations.

		TOLERANCES UNLESS SPECIFIED:		LEESON	ELECTRIC MOTORS GEARMOTORS AND DRIVES	DRAWN	KA 09/02/2008	
		DEC INCHES				CHK	RVD 09/02/2008	
		X ±.1				APPR		
		.XX ±.03				SCALE	3:8	
		.XXX ±.005		TITLE	OUTLINE - 140T/56HZ FRAME	REF	028765	
		.XXX ±.005		TEFC - RIGID		FMF	120946	
		MATL		FINISH	GENERAL PURPOSE	PAGE	OF	
NO	REVISION	BY & DATE	CHK ANG ±1/2"	RFP	PREV	SIZE	DRAWING NO	REV
	THIRD ANGLE PROJECTION			NETWORK FILE NAME		B	028877	

005200-01

VIEW FROM OUTSIDE OF MOTOR AT SWITCH END.

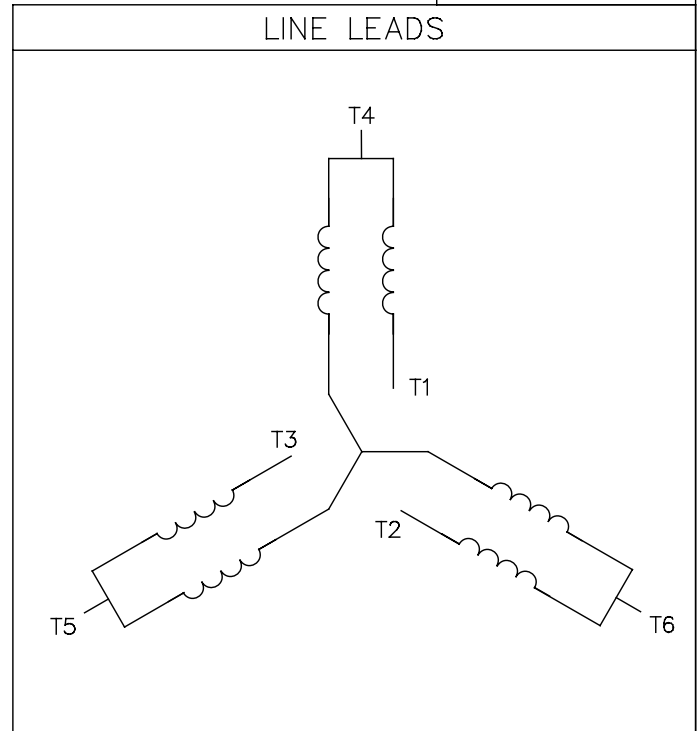
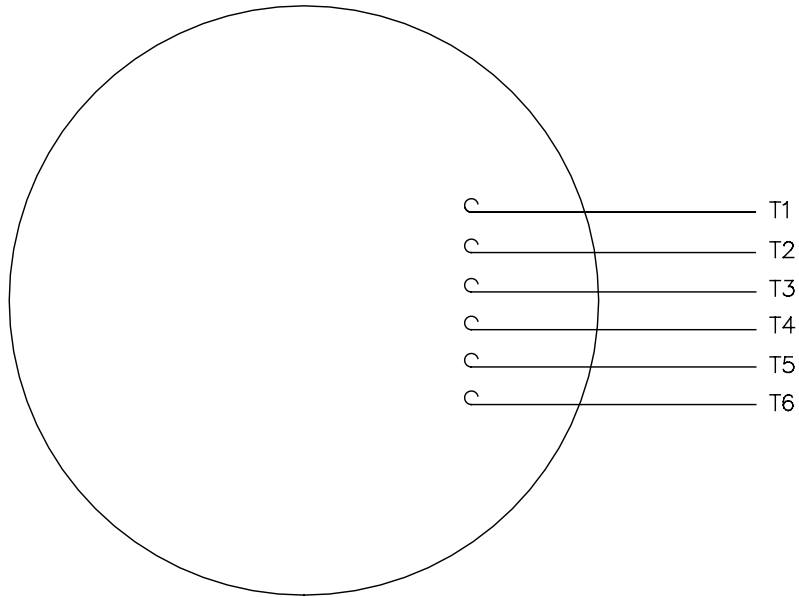

SPEED	L1	L2	L3	JOIN	SEPARATE
HIGH	T6	T4	T5	(T1,T2,T3)	
LOW	T1	T2	T3		(T4)(T5) (T6)

				TOLERANCES UNLESS OTHERWISE SPECIFIED		Regal Beloit America, Inc.				
				DECIMALS						
				.00	± .01	DRAWN PG 08/08/83	TITLE EXTERNAL WIRING DIAGRAM TYPE "T" W/O PROTECTOR			
04	SPEED WAS VOLTAGE	EPB	1/17/00	.000	± .005	CH'K'D. DLL 08/09/83				
03	REDRAWN TO CURRENT STANDARDS	DBT	05/30/97	.0000	± .0005	APPR. KG 08/09/83	MAT'L DECAL - 004183/080066 2 SPEED 1 WDG. VARIABLE TORQUE MOTOR			
NO.	REVISION	BY	DATE	FRACTIONS	± 1/64	SCALE 1=1				
THIS DRAWING IN DESIGN AND DETAIL IS OUR PROPERTY AND MUST NOT BE USED EXCEPT IN CONNECTION WITH OUR WORK ALL RIGHTS OF DESIGN AND INVENTION ARE RESERVED				ANGLES	± 1/2°	REF. 080066	FINISH		SIZE	DRAWING NO. 005200-01
				INCH/MM		FMF 83648D1			A	



LEESON ELECTRIC CORPORATION
 TYPICAL PERFORMANCE CURVE for AC MOTOR

Model No 120946.00

Catalog No 120946.00

Curve at 460 Volts HP 2&0.5 PHASE 3
60 HZ
2 HP VOLTS 208-230&208-230

HZ 60&60 RPM 1725&850

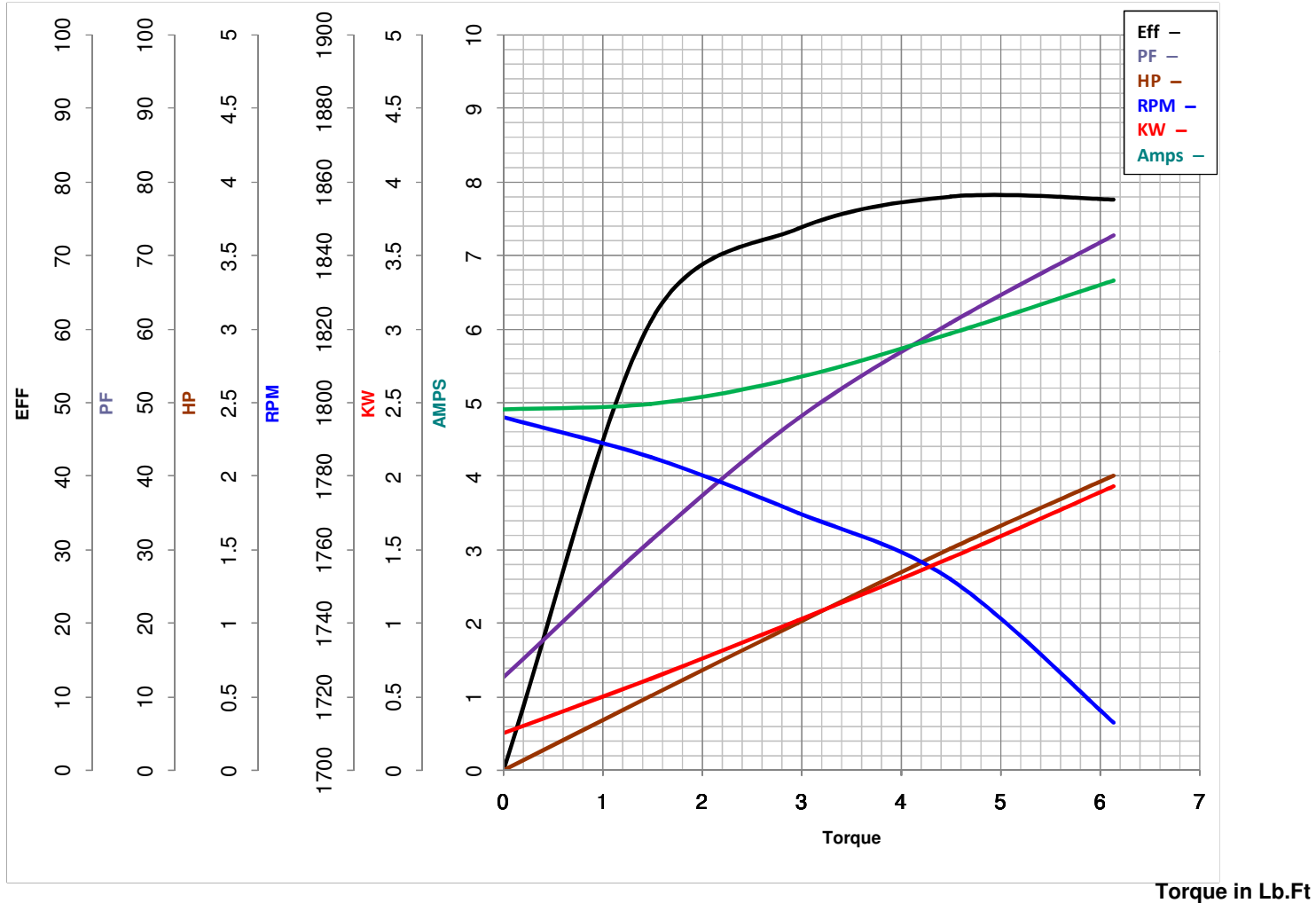

FL TORQUE	<u>6.14</u>	Lb.Ft	FL AMPS	<u>6.4</u>	
BD TORQUE	<u>22.5</u>	Lb.Ft	PU TORQUE	<u>17.3</u>	Lb.Ft
LR TORQUE	<u>17.4</u>	Lb.Ft	LR AMPS	<u>43.5</u>	
WINDING	<u>T63(4-8)33-2</u>		Date	<u>6/4/2018</u>	