

# PRODUCT INFORMATION PACKET



Model No: C184T17FK15E  
Catalog No: 131502.00  
..5HP..1760RPM.184TC.TEFC./V.3PH.60HZ.CONT.40C.1.15SF.RIGID  
C.C184T17FK15E.....WATTS AVER.AUTOMATIC.....  
Totally Enclosed Fan Cooled (TEFC)



Regal and Leeson are trademarks of Regal Beloit Corporation or one of its affiliated companies.  
©2018 Regal Beloit Corporation, All Rights Reserved. MC017097E





**Nameplate Specifications**

Output HP	<b>5 Hp</b>	Output KW	<b>3.7 kW</b>
Frequency	<b>60 Hz</b>	Voltage	<b>230/460 V</b>
Current	<b>12.6/6.3 A</b>	Speed	<b>1760 rpm</b>
Service Factor	<b>1.15</b>	Phase	<b>3</b>
Efficiency	<b>89.5 %</b>	Duty	<b>Continuous</b>
Insulation Class	<b>F</b>	Design Code	<b>B</b>
KVA Code	<b>G</b>	Frame	<b>184TC</b>
Enclosure	<b>Totally Enclosed Fan Cooled</b>	Overload Protector	<b>No</b>
Ambient Temperature	<b>40 °C</b>	Drive End Bearing Size	<b>6206</b>
Opp Drive End Bearing Size	<b>6205</b>	UL	<b>Recognized</b>
CSA	<b>Y</b>	CE	<b>Y</b>
IP Code	<b>43</b>		

**Technical Specifications**

Electrical Type	<b>Squirrel Cage Induction Run</b>	Starting Method	<b>Across The Line</b>
Poles	<b>4</b>	Rotation	<b>Reversible</b>
Mounting	<b>Rigid base</b>	Motor Orientation	<b>HORIZONTAL</b>
Drive End Bearing	<b>BALL</b>	Opp Drive End Bearing	<b>BALL</b>
Frame Material	<b>Rolled Steel</b>	Shaft Type	<b>T</b>
Overall Length	<b>14.97 in</b>	Frame Length	<b>9.50 in</b>
Shaft Diameter	<b>1.125 in</b>	Shaft Extension	<b>2.75 in</b>
Assembly/Box Mounting	<b>F1 ONLY</b>		
Outline Drawing	<b>035453-950</b>	Connection Diagram	<b>005010.20</b>

RBC PROPRIETARY AND CONFIDENTIAL INFORMATION  
 This document is the property of REGAL-BELOIT CORPORATION ("RBC") including its subsidiaries and divisions and contains proprietary information of RBC. This document is loaned on the express condition that neither the information contained therein shall be disclosed to others without the express written consent of RBC, and that the information shall be used by the recipient only as approved expressly by RBC. This document shall be returned to RBC upon request. This document may be subject to certain restrictions under U.S. export control laws and regulations.

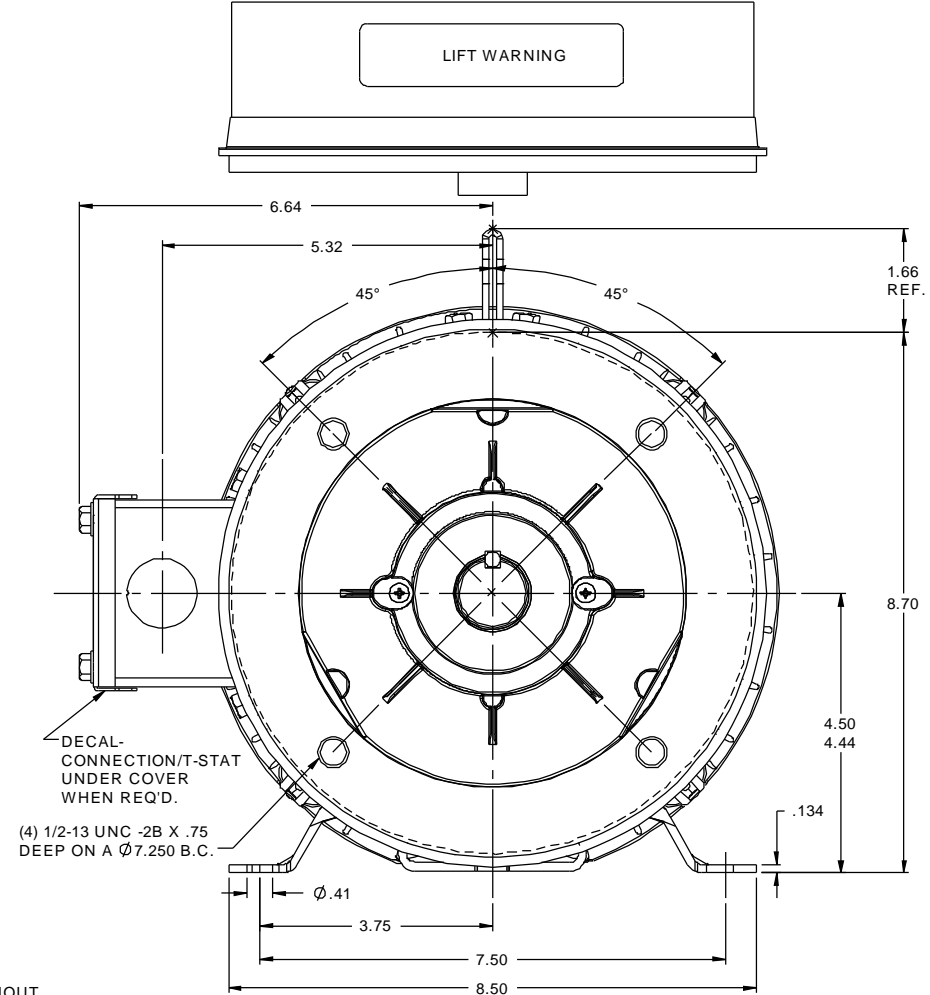
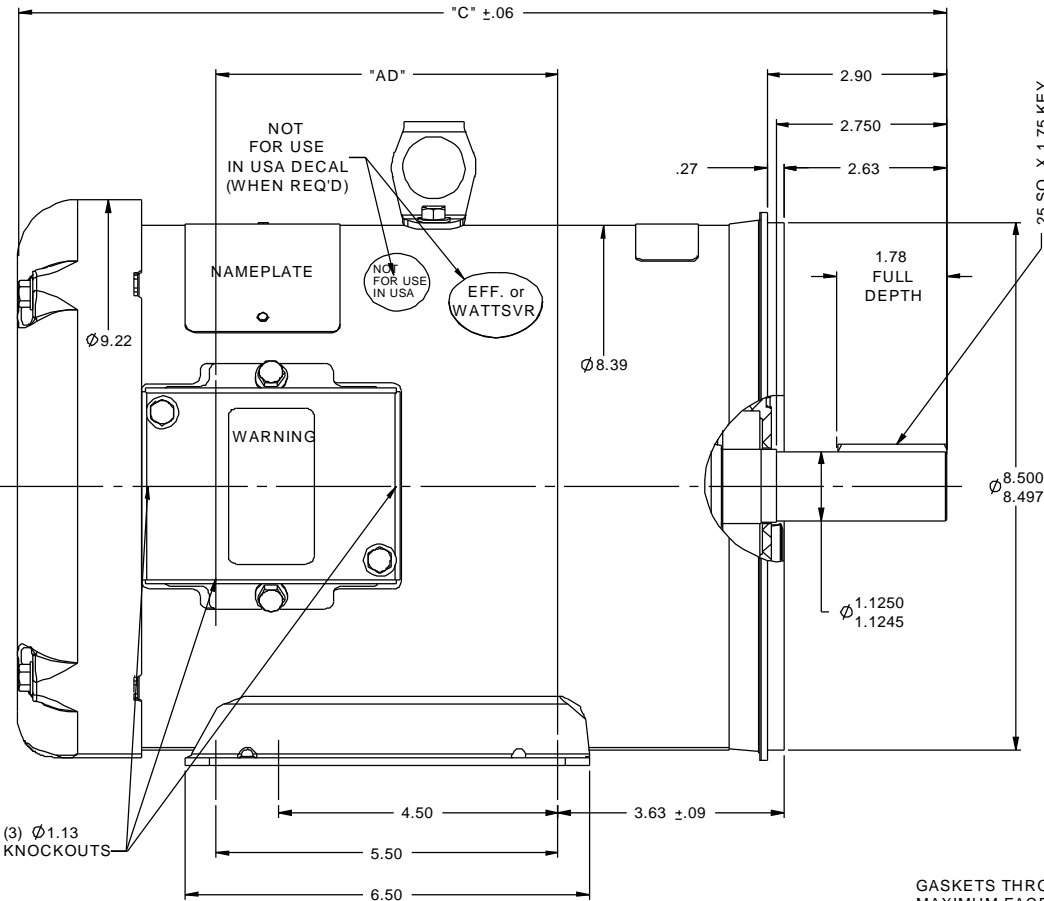

GASKETS THROUGHOUT  
 MAXIMUM FACE RUNOUT TO BE .004 T.I.R.  
 MAXIMUM PILOT ECCENTRICITY TO BE .004 T.I.R.  
 PERMISSIBLE SHAFT RUNOUT TO BE .002 T.I.R.

DASH NO.	"C"	"AD"
850	13.97	4.50
900	14.47	5.00
950	14.97	5.50
1000	15.47	6.00
1050	15.97	6.50
1100	16.47	7.00
1150	16.97	7.50

				TOLERANCES UNLESS SPECIFIED		DRAWN RDW 1/21/03	
				DEC	INCHES	CHK	
				X	±.1	APPR SW 1/21/03	
				XX	±.03	SCALE 1:2	
1	ADDED DECAL NOT FOR USE IN USA	GR 06/04/12	JD	XXX	±.005	REF 035346	
-	UPDATED & REDRAWN IN SOLIDWORKS	LST 12/17/2009	XX	XXXX	±.0005	FMF	
NO	REVISION	BY & DATE	CHK	ANG	±1/2°	PAGE OF	
THIRD ANGLE PROJECTION			RFP		PREV	SIZE	DRAWING NO
			NETWORK FILE NAME		B	035453	REV
TITLE OUTLINE - 180TC FRAME						1	
TEFC - RIGID "C"						MAT'L	
FINISH						OF	



VIEW FROM OUTSIDE OF MOTOR AT SWITCH END. Uncontrolled Copy

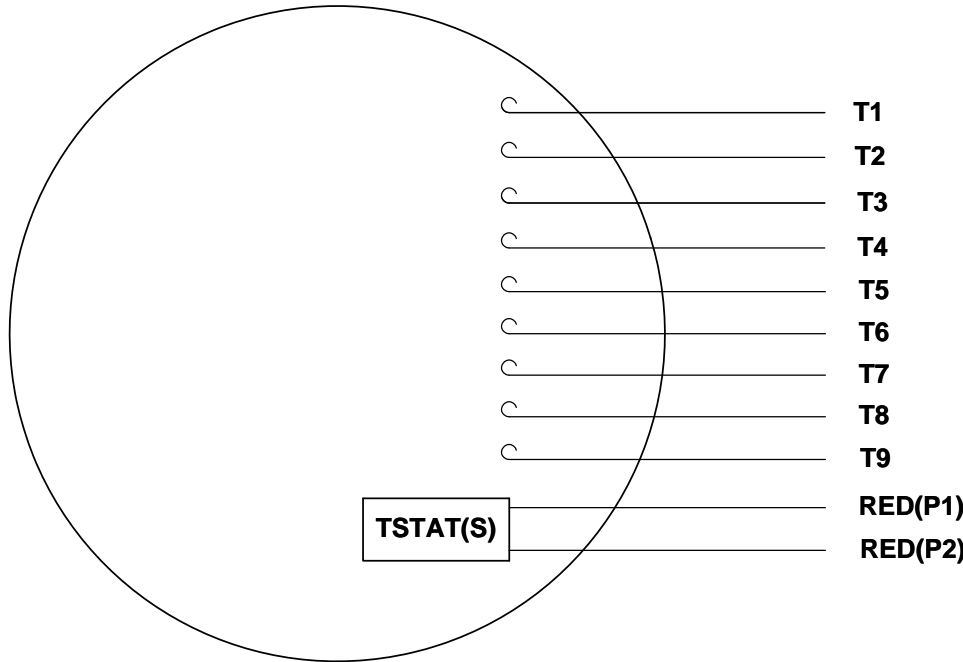

LINE LEADS

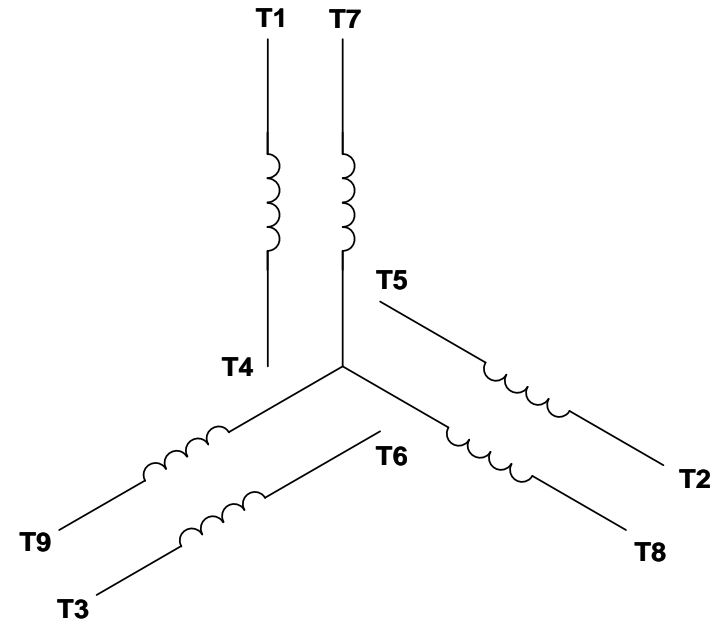

VOLTAGE	L1	L2	L3	JOIN & INSULATE
HIGH	T1	T2	T3	(T4,T7) (T5,T8) (T6,T9)
LOW	T1,T7	T2,T8	T3,T9	T4,T5,T6

DRAWING REVISION G REVISION BY MVG DATE 04/05/2017

ECO ECO-0121253 APPROVED BY SM DATE 04/05/2017

ECO DESCRIPTION  
ADDED P1 & P2 FOR TSTAT

COPYRIGHT REGAL BELOIT AMERICA, INC. ALL RIGHTS RESERVED.  
PROPRIETARY AND CONFIDENTIAL INFORMATION - THIS DOCUMENT IS THE PROPERTY OF  
REGAL BELOIT AMERICA, INC. ('OWNER') AND CONTAINS OWNER'S PROPRIETARY  
INFORMATION. ANY PERSON, CORPORATION OR OTHER FIRM RECEIVING IT IS DEEMED,  
BY RECEIVING IT, TO AGREE THAT IT, AND/OR ANY PART OF IT, SHALL NOT BE DISCLOSED  
TO ANY PERSON, CORPORATION OR OTHER ENTITY, DUPLICATED, AND/OR USED, EXCEPT  
AS EXPRESSLY APPROVED IN WRITING IN ADVANCE BY OWNER. THIS DOCUMENT SHALL  
BE RETURNED TO OWNER UPON REQUEST. IT MAY BE SUBJECT TO CERTAIN  
RESTRICTIONS UNDER APPLICABLE EXPORT CONTROL LAWS AND REGULATIONS.

TOLERANCES UNLESS OTHERWISE SPECIFIED:

DEC.	INCH	mm	ANGLE
.X	±0.1	[±2.5]	±0.5°
.XX	±0.01	[±0.25]	
.XXX	±0.005	[±0.127]	
.XXXX	±0.0005	[±0.0127]	

REMOVE BURRS & BREAK SHARP  
EDGES: .003/.015 [.076/.381] X 45°  
CORNER FILLETS: R.02 [.51]  
MACHINED SURFACES: 125/3.2  
INCH/mm  
mm SHOWN IN [BRACKETS]

DRAWN BY DBT 12/16/97

DATE

APPROVED BY KH 12/17/97

DATE

REFERENCE

THIRD ANGLE PROJECTION

**REGAL**™ Regal Beloit America, Inc.

DESCRIPTION  
**CONN DIAGRAM-EXTERNAL**  
3 PHASE WITH PROTECTOR

MATERIAL DECAL - 004014 (TSTAT) - 080582 PROCESS/FINISH STOCK

SIZE A DRAWING NUMBER 00501020 SHEET 1 OF 1

