

PRODUCT INFORMATION PACKET



Model No: C6C17WC2G
Catalog No: 114311.00
1/3HP.C-FACE LESS BASE -
1725RPM.56.TEFC.V.1PH.60HZ.CONT.NOT.40C.1.15SF.ROUND.WASHGUARD.C6C17WC2G
General Purpose



Regal and Leeson are trademarks of Regal Beloit Corporation or one of its affiliated companies.

©2018 Regal Beloit Corporation, All Rights Reserved. MC017097E





Nameplate Specifications

Output HP	0.33 Hp	Output KW	0.25 kW
Frequency	60 Hz	Voltage	115/208-230 V
Current	6.4/3.4-3.2 A	Speed	1725 rpm
Service Factor	1.15	Phase	1
Efficiency	62 %	Duty	Continuous
Insulation Class	F	Design Code	N
KVA Code	M	Frame	56C
Enclosure	Totally Enclosed Fan Cooled	Overload Protector	No
Ambient Temperature	40 °C	Drive End Bearing Size	6205
Opp Drive End Bearing Size	6203	UL	Recognized
CSA	Y	CE	N
IP Code	55		

Technical Specifications

Electrical Type	Capacitor Start Induction Run	Starting Method	Across The Line
Poles	4	Rotation	Selective Counterclockwise
Mounting	Round	Motor Orientation	HORIZONTAL
Drive End Bearing	BALL	Opp Drive End Bearing	BALL
Frame Material	Rolled Steel	Shaft Type	NEMA 56
Overall Length	10.37 in	Frame Length	4.50 in
Shaft Diameter	0.625 in	Shaft Extension	1.88 in
Assembly/Box Mounting	F1 ONLY		
Outline Drawing	607-0010-450A	Connection Diagram	005278.07

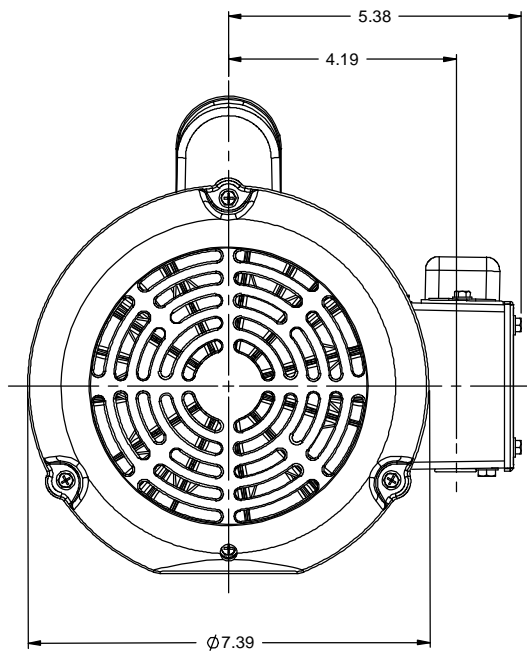

**WITH SHORTER FRAME LENGTHS PLACE THESE DECALS ON OPPOSITE SIDE OF MOTOR NEXT TO NAMEPLATE.

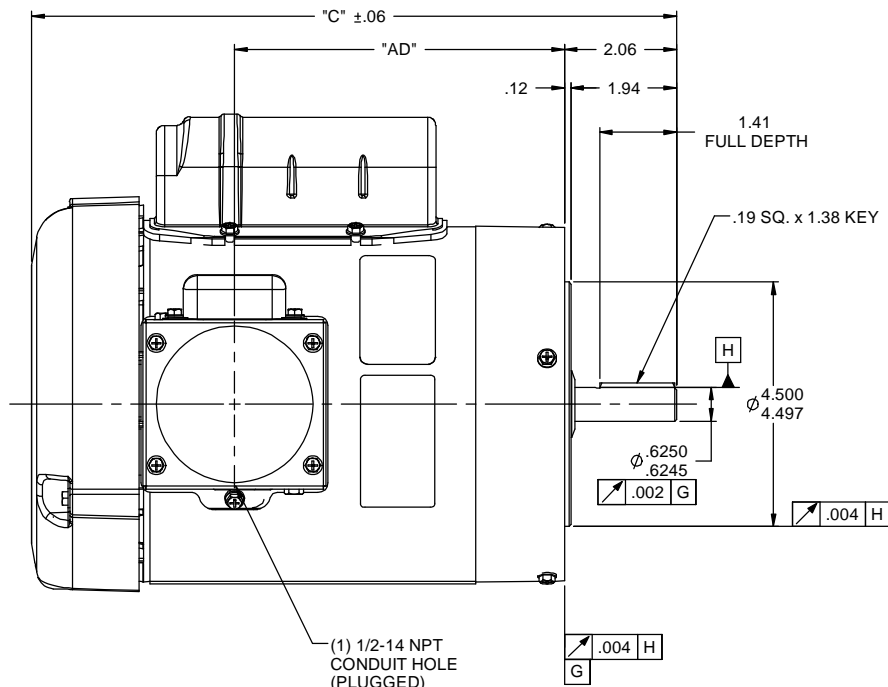

(1) 1/2-14 NPT CONDUIT HOLE (PLUGGED)

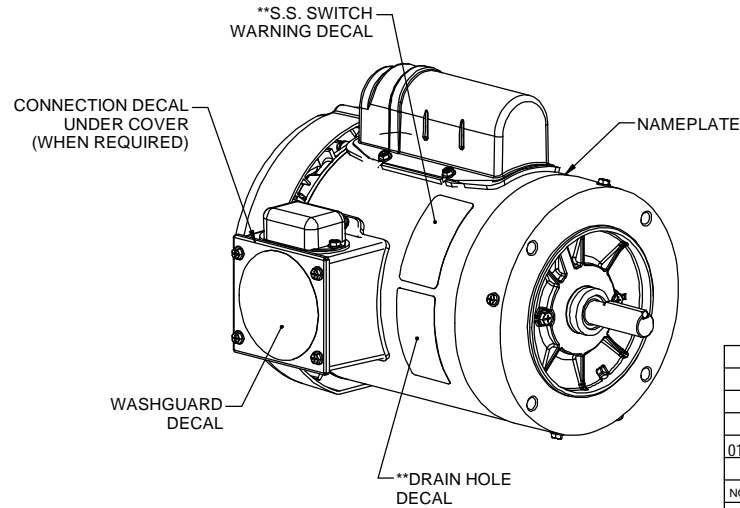
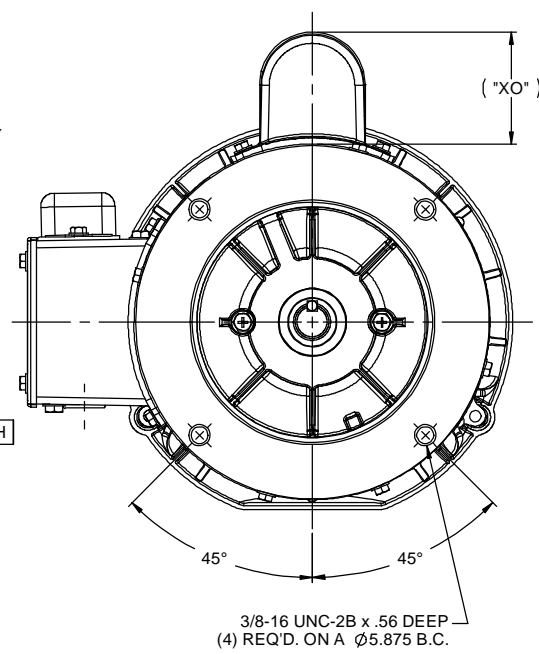

DASH NO	"C"	"AD"	"XO"
** 450A	10.37	4.56	2.00
** 475A	10.62	4.81	2.00
500A	10.87	5.06	2.00
525A	11.12	5.31	2.00
550A	11.37	5.56	2.00
575A	11.62	5.81	2.00
600A	11.87	6.06	2.00
625A	12.12	6.31	2.00
650A	12.37	6.56	2.00
700A	12.87	7.06	2.00
750A	13.37	7.56	2.00
800A	13.87	8.06	2.00

DASH NO	"C"	"AD"	"XO"
** 450B	10.37	4.56	2.25
** 475B	10.62	4.81	2.25
500B	10.87	5.06	2.25
525B	11.12	5.31	2.25
550B	11.37	5.56	2.25
575B	11.62	5.81	2.25
600B	11.87	6.06	2.25
625B	12.12	6.31	2.25
650B	12.37	6.56	2.25
700B	12.87	7.06	2.25
750B	13.37	7.56	2.25
800B	13.87	8.06	2.25

WASHGUARD MOTOR

- SPECIAL FEATURES:
1. SHAFT SEAL & V-RING.
 2. PLUGGED DRAIN HOLES IN ENDBELLS & CONDUIT BOX.
 3. BUNA-N GASKETS THROUGHOUT.
 4. STAINLESS STEEL SHAFT, HARDWARE & NAMEPLATE.
 5. SOLID STATE SWITCH MOUNTED TO CONDUIT BOX.

		TOLERANCES UNLESS SPECIFIED		ELECTRIC MOTORS GEARMOTORS AND DRIVES		DRAWN PG 02/10/11	
		DEC	INCHES			CHK	APPR
		X	±.1	TITLE OUTLINE - 56C FRAME		SCALE 7:16	
		XX	±.03	TEFC - "C" FACE		REF 028866	
01 ADDED NOTE FOR LOCATION OF DECALS ON SHORTER FRAME MOTORS ISAAC 12-3707		GS	8/2/12	XXXX	±.0005	MATL WASHGUARD	FMF 114310.00
NO	REVISION	BY & DATE	CHK	ANG	±1/2"	FINISH	PAGE OF
THIRD ANGLE PROJECTION				RFP	PREV	SIZE B	DRAWING NO 607-0010
				NETWORK FILE NAME 607-0010		REV 01	

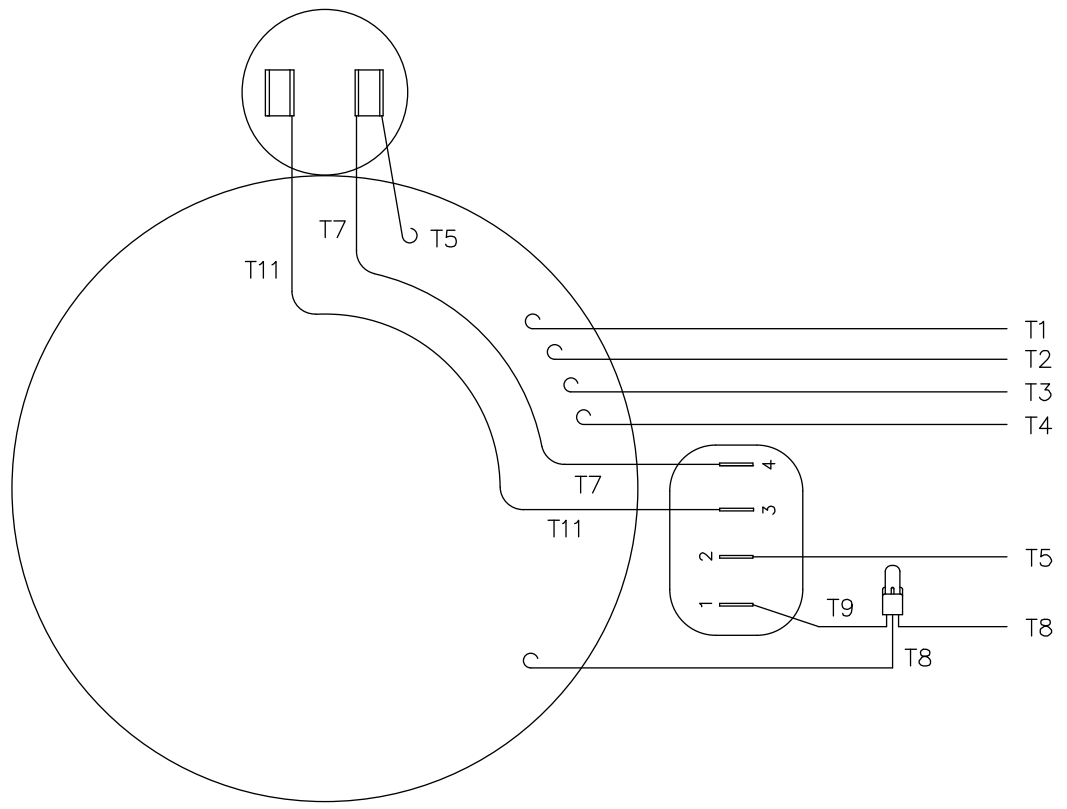

VIEW FROM OUTSIDE OF MOTOR AT SWITCH END.

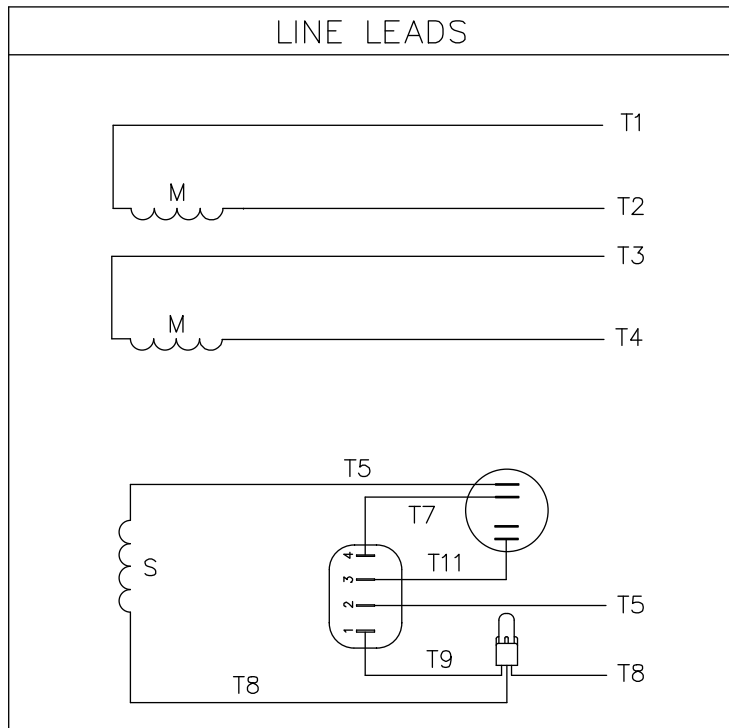

	ROTATION FACING LEAD END	L1	L2	JOIN & INSULATE
HIGH VOLT	C.C.W.	T1	T4 T5	T2, T3 T8
	C.W.	T1	T4 T8	T2, T3 T5
LOW VOLT	C.C.W.	T1, T3 T8	T2, T4 T5	
	C.W.	T1, T3 T5	T2, T4 T8	

				TOLERANCES UNLESS OTHERWISE SPECIFIED		LEESON ELECTRIC CORPORATION				
				DECIMALS						
				.00	± .01	DRAWN	TITLE			
				.000	± .005	CH'K'D.	EXTERNAL WIRING DIAGRAM TYPE "C" W/O PROTECTOR			
01	ADDED DECAL FOR STOCK MOTORS ECR 0042509	GWS	9/10/13	.0000	± .0005	APPR.	MAT'L. DECAL - 004012			
NO.	REVISION	BY	DATE	FRACTIONS	± 1/64	SCALE	STOCK MOTORS TO USE DECAL 214-0122-001			
THIS DRAWING IN DESIGN AND DETAIL IS OUR PROPERTY AND MUST NOT BE USED EXCEPT IN CONNECTION WITH OUR WORK ALL RIGHTS OF DESIGN AND INVENTION ARE RESERVED				ANGLES	± 1/2*	REF.	FINISH		SIZE	DRAWING NO.
				INCH/MM		FMF	STANDARD		A	005278-07



LEESON ELECTRIC CORPORATION
TYPICAL PERFORMANCE CURVE for AC MOTOR

Model No 114311.00

Catalog No 114311.00

Curve at 230 Volts HP 0.33 PHASE 1
60 HZ
0.33 HP VOLTS 115/208-230
HZ 60 RPM 1725

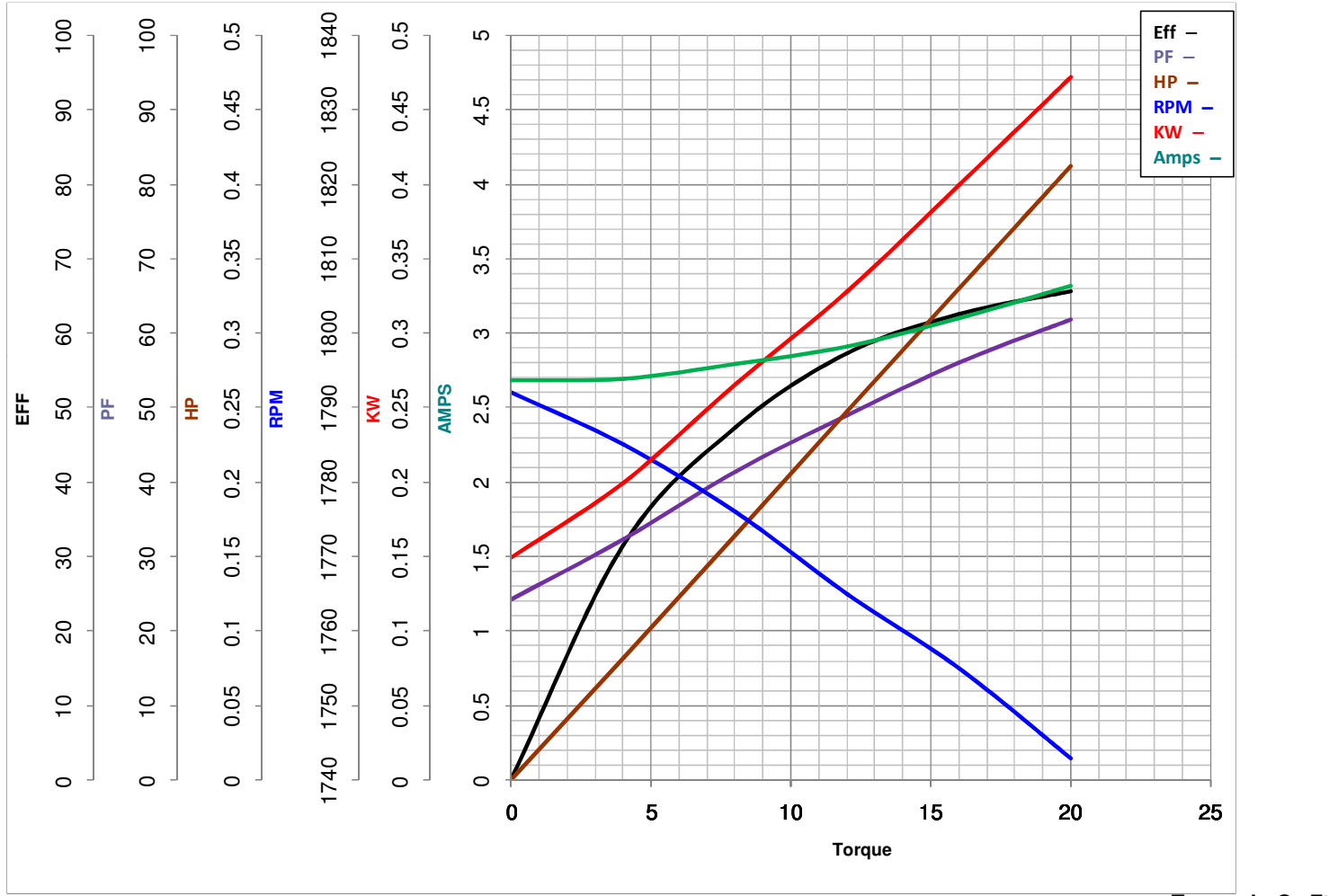

FL TORQUE	<u>16</u>	Oz.Ft	FL AMPS	<u>6.4/3.4-3.2</u>
BD TORQUE	<u>49.6</u>	Oz.Ft	PU TORQUE	<u>46.0</u> Oz.Ft
LR TORQUE	<u>60.5</u>	Oz.Ft	LR AMPS	<u>15.4</u>
WINDING	C634260-3		Date	<u>4/24/2018</u>