

PRODUCT INFORMATION PACKET



Model No: C6C34WK5N

Catalog No: 113584.00

1.5HP.- C-FACE WITH BASE -.3450RPM.56.TEFC.115/208-230V.1PH.60HZ.CONT.NOT.40C.1.15SF.RIGID
C.WASHGUARD.C6C34WK5N

General Purpose



Regal and Leeson are trademarks of Regal Beloit Corporation or one of its affiliated companies.

©2018 Regal Beloit Corporation, All Rights Reserved. MC017097E





Nameplate Specifications

Output HP	1.50 Hp	Output KW	1.1 kW
Frequency	60 Hz	Voltage	115/208-230 V
Current	17.0/8.5 A	Speed	3450 rpm
Service Factor	1.15	Phase	1
Efficiency	72 %	Duty	Continuous
Insulation Class	F	Design Code	L
KVA Code	H	Frame	56C
Enclosure	Totally Enclosed Fan Cooled	Overload Protector	No
Ambient Temperature	40 °C	Drive End Bearing Size	6205
Opp Drive End Bearing Size	6203	UL	Recognized
CSA	Y	CE	N
IP Code	55		

Technical Specifications

Electrical Type	Capacitor Start Induction Run	Starting Method	Across The Line
Poles	2	Rotation	Selective Counterclockwise
Mounting	Rigid base	Motor Orientation	HORIZONTAL
Drive End Bearing	BALL	Opp Drive End Bearing	BALL
Frame Material	Rolled Steel	Shaft Type	NEMA 56
Overall Length	12.37 in	Frame Length	6.50 in
Shaft Diameter	0.625 in	Shaft Extension	1.88 in
Assembly/Box Mounting	F1 ONLY		
Outline Drawing	607-0008-650B	Connection Diagram	005278.07

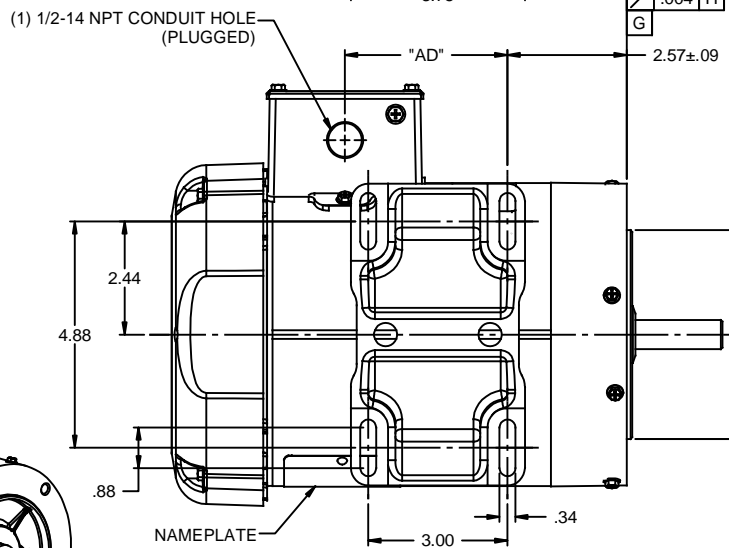
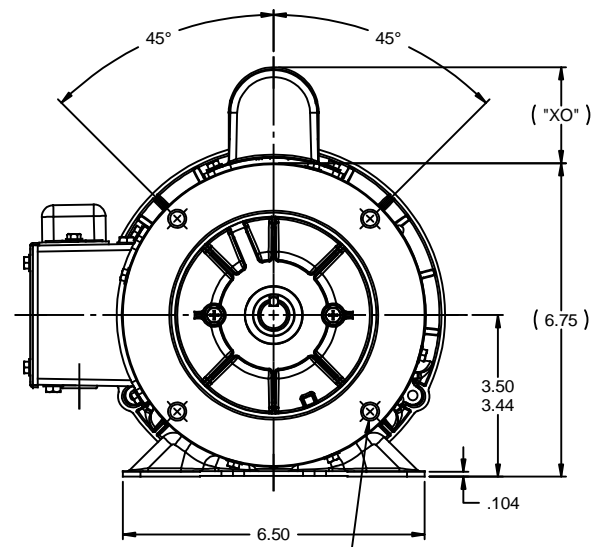
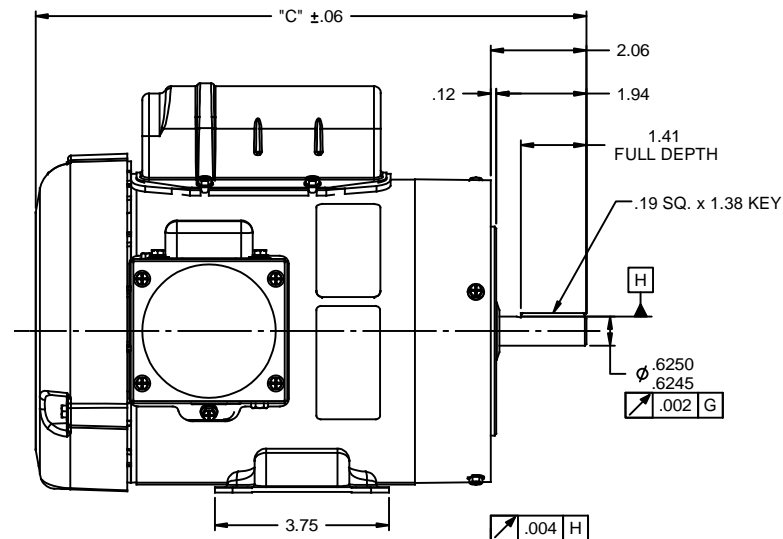
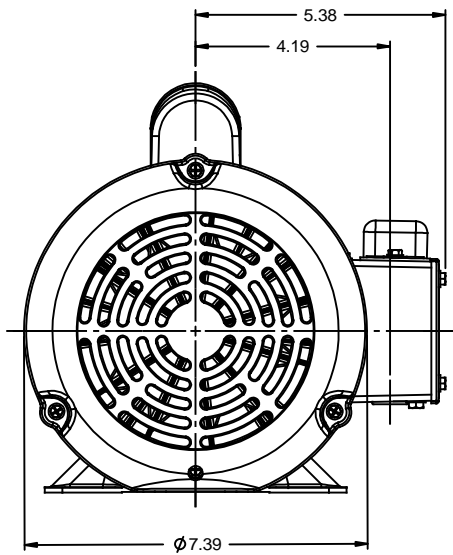

3/8-16 UNC-2B x .56 DEEP
(4) REQ'D. ON A Ø5.875 B.C.

WASHGUARD MOTOR

- SPECIAL FEATURES:
1. SHAFT SEALS & V-RING.
 2. PLUGGED DRAIN HOLES IN ENDBELLS & CONDUIT BOX.
 3. BUNA-N GASKETS THROUGHOUT.
 4. STAINLESS STEEL SHAFT, HARDWARE & NAMEPLATE.
 5. SOLID STATE SWITCH MOUNTED TO CONDUIT BOX.

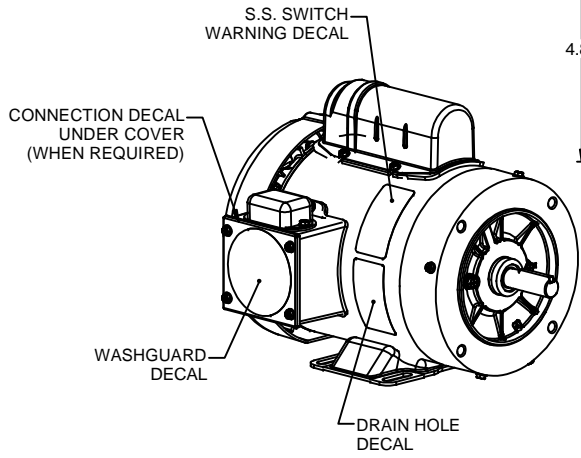

DASH NO.	"C"	"AD"	"XO"	DASH NO.	"C"	"AD"	"XO"
450A	10.37	2.00	2.00	450B	10.37	2.00	2.25
475A	10.62	2.25	2.00	475B	10.62	2.25	2.25
500A	10.87	2.50	2.00	500B	10.87	2.50	2.25
525A	11.12	2.75	2.00	525B	11.12	2.75	2.25
550A	11.37	3.00	2.00	550B	11.37	3.00	2.25
575A	11.62	3.25	2.00	575B	11.62	3.25	2.25
600A	11.87	3.50	2.00	600B	11.87	3.50	2.25
625A	12.12	3.75	2.00	625B	12.12	3.75	2.25
650A	12.37	4.00	2.00	650B	12.37	4.00	2.25

TOLERANCES UNLESS SPECIFIED				LEESON ELECTRIC MOTORS GEARMOTORS AND DRIVES		DRAWN PG 02/08/11	
DEC	INCHES	FINISH	TITLE	CHK	SCALE	REF	APPR
X	±.1		OUTLINE - 56C FRAME		3:8	028881	
.XX	±.03		TEFC - RIGID "C" FACE				
.XXX	±.005		MATL WASHGUARD				
.XXXX	±.0005						
NO	REVISION	BY & DATE	CHK ANG ±1/2°	FINISH	SCALE	PAGE	OF
	THIRD ANGLE PROJECTION		RFP	PREV	SIZE	DRAWING NO	REV
			NETWORK FILE NAME	607-0008	B	607-0008	

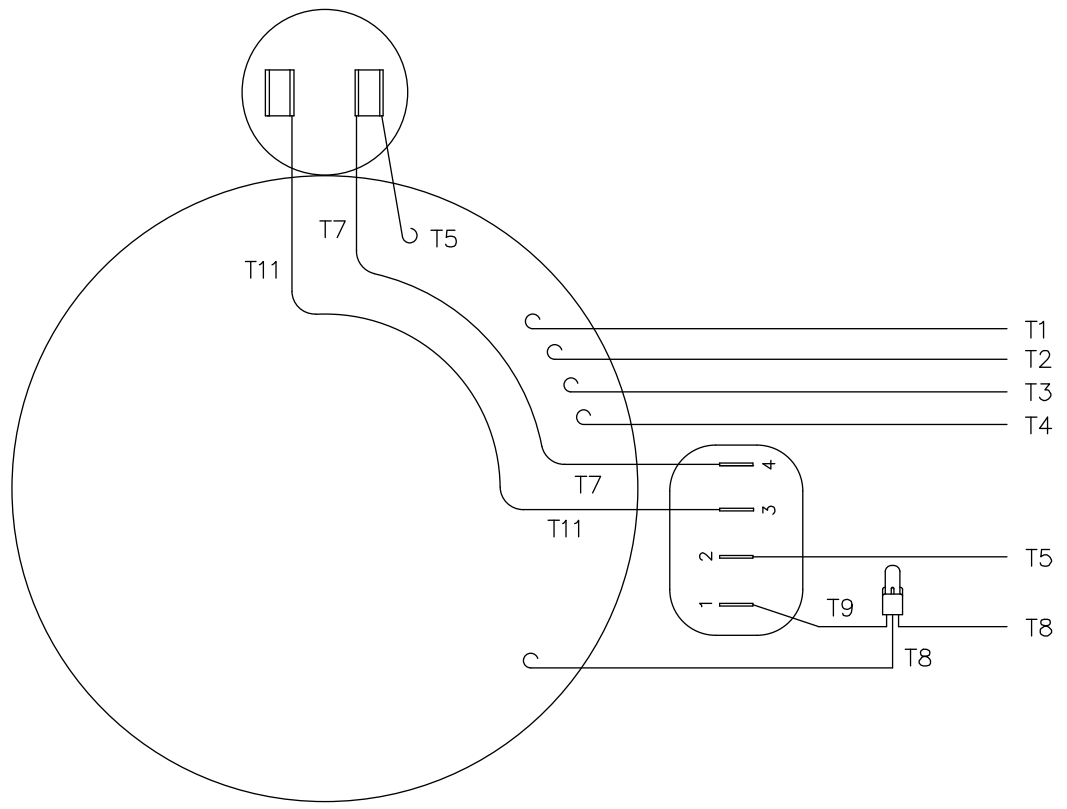

VIEW FROM OUTSIDE OF MOTOR AT SWITCH END.

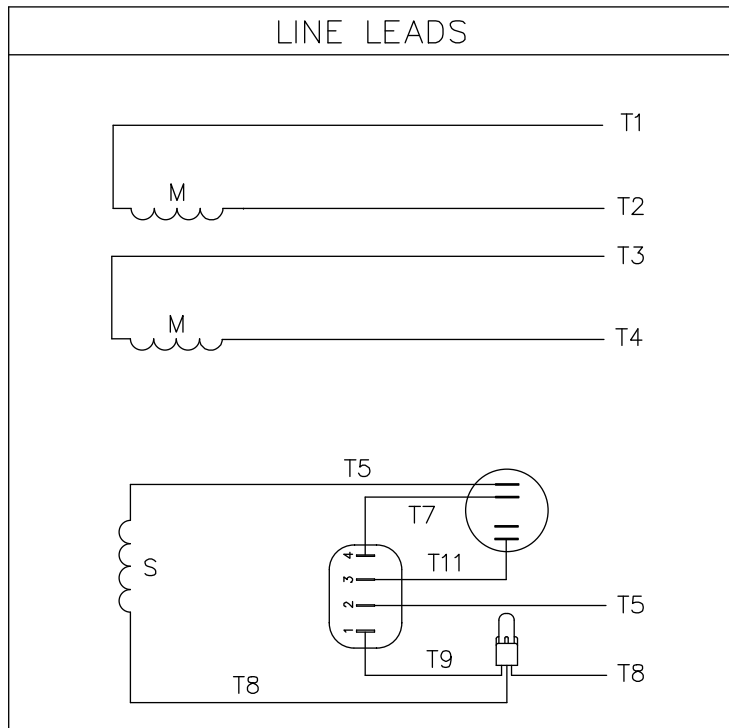

	ROTATION FACING LEAD END	L1	L2	JOIN & INSULATE
HIGH VOLT	C.C.W.	T1	T4 T5	T2, T3 T8
	C.W.	T1	T4 T8	T2, T3 T5
LOW VOLT	C.C.W.	T1, T3 T8	T2, T4 T5	
	C.W.	T1, T3 T5	T2, T4 T8	

				TOLERANCES UNLESS OTHERWISE SPECIFIED		LEESON ELECTRIC CORPORATION				
				DECIMALS						
				.00	± .01	DRAWN	TITLE			
				.000	± .005	CH'K'D.	EXTERNAL WIRING DIAGRAM TYPE "C" W/O PROTECTOR			
01	ADDED DECAL FOR STOCK MOTORS ECR 0042509	GWS	9/10/13	.0000	± .0005	APPR.	MAT'L. DECAL - 004012			
NO.	REVISION	BY	DATE	FRACTIONS	± 1/64	SCALE	STOCK MOTORS TO USE DECAL 214-0122-001			
THIS DRAWING IN DESIGN AND DETAIL IS OUR PROPERTY AND MUST NOT BE USED EXCEPT IN CONNECTION WITH OUR WORK ALL RIGHTS OF DESIGN AND INVENTION ARE RESERVED				ANGLES	± 1/2*	REF.	FINISH		SIZE	DRAWING NO.
				INCH/MM		FMF	STANDARD		A	005278-07



LEESON ELECTRIC CORPORATION
 TYPICAL PERFORMANCE CURVE for AC MOTOR

Model No 113584.00

Catalog No 113584.00

Curve at 230 Volts HP 1.50 PHASE 1
60 HZ
1.5 HP VOLTS 115/208-230

HZ 60 RPM 3450

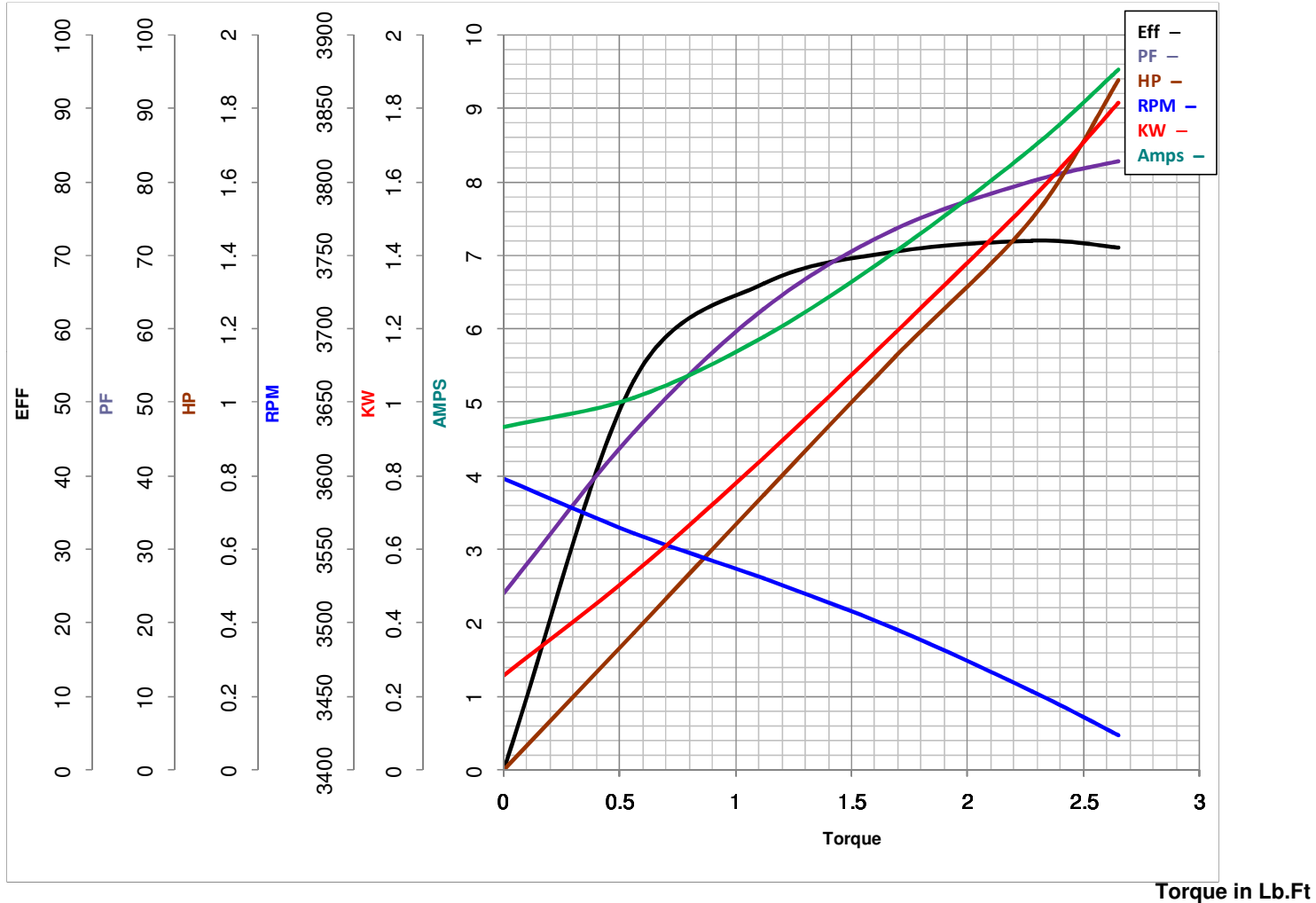

FL TORQUE	<u>2.28</u>	Lb.Ft	FL AMPS	<u>17/8.5</u>	
BD TORQUE	<u>5.6</u>	Lb.Ft	PU TORQUE	<u>5.3</u>	Lb.Ft
LR TORQUE	<u>5.5</u>	Lb.Ft	LR AMPS	<u>46</u>	
WINDING	C632212-3		Date	<u>4/23/2018</u>	