

BALDOR® • RELIANCE 

Product Information Packet

CDPX3545

1HP,1750RPM,DC,56C,X3536P,XPFC,F1

Part Detail							
Revision:	AA	Status:	PRD/A	Change #:		Proprietary:	No
Type:	DC	Prod. Type:	3536P	Elec. Spec:	35WGZ235	CD Diagram:	CD0194
Enclosure:	XPFC	Mfg Plant:		Mech. Spec:	35P565	Layout:	35LYP565
Frame:	56C	Mounting:	F1	Poles:	00	Created Date:	
Base:	RG	Rotation:	R	Insulation:	F	Eff. Date:	01-04-2018
Field Type:		Literature:		Elec. Diagram:		Replaced By:	

Specs			
Enclosure:	XPFC		
Frame:	56C		
Frame Material:	Steel		
XP Class and Group:	CLI GP D; CLII GP F,G		
Agency Approvals:	CSA		
	UL		
	UR		
Base Indicator:	Rigid		
Bearing Grease Type:	Polyrex EM (-20F +300F)		
Drip Cover:	No Drip Cover		
Duty Rating:	CONT		
Feedback Device:	NO FEEDBACK		
Heater Indicator:	No Heater		
Insulation Class:	F		
Lifting Lugs:	No Lifting Lugs		
Motor Lead Quantity/Wire Size:	2 @ 14 AWG		

Motor Lead Exit:	Ko Box		
Motor Lead Termination:	Flying Leads		
Mounting Arrangement:	F1		
Product Family:	Hazardous Location Motor		
Pulley End Bearing Type:	Sealed Bearing		
Shaft Extension Location:	Pulley End		
Shaft Ground Indicator:	No Shaft Grounding		
Shaft Rotation:	Reversible		
Shaft Slinger Indicator:	No Slinger		
Motor Standards:	NEMA		
XP Division:	Division I		
XP Temp Code:	T3C		

Parts List		
Part Number	Description	Quantity
SA005563	SA 35P565Z235G1	1.000 EA
AA003212	AA 35P565Z235G1	1.000 EA
BP5035C01	BRUSH ASSY, HELWIG GRADE 6H3	2.000 EA
BP5034	BRSH SPRG ASSY. "REV.B" 35X PM MTR(VULCA	2.000 EA
MJ5000A01	SEALANT, CHICO A COMPOUND	0.005 LB
35CB3001A02SP	EXPL PROOF CONDUIT BOX, 3/4"PIPE TAP LEA	1.000 EA
HW4002A02	1-11.5X2LG PIPE NIPPLE (F/S)	1.000 EA
11XW1032G06	10-32 X .38, TAPTITE II, HEX WSHR SLTD U	1.000 EA
HW3001B01	BRASS CUP WASHER, FOR #10 SCREW	1.000 EA
35EP2700A01	FR EP-203 BRG- X35L-M	1.000 EA
HW4030A01	1-1/2" N.P.T. PIPE PLUG W/SQ.HEAD	2.000 EA
51XW0832A07	8-32 X .44, TAPTITE II, HEX WSHR SLTD SE	4.000 EA
HW5100A03	WAVY WASHER (W1543-017)	1.000 EA
35EP3702A06	PU EP-205 BRG-35X-56C-143-5TC	1.000 EA
51XN1032A20	10-32 X 1 1/4 HX WS SL SR	2.000 EA
HA3013A01	1/2-20X5/8 SPL.HX BOLT	2.000 EA
HW3021C06	3/32 DI X .625 PIN (F/S)	2.000 EA
XY3118A12	5/16-18 HEX NUT DIRECTIONAL SERRATION	4.000 EA
35FN3002A05SP	EXFN, PLASTIC, 6.376 OD, .638 ID	1.000 EA
51XB1214A16	12-14X1.00 HXWSSLD SERTYB	1.000 EA
51XW1032A06	10-32 X .38, TAPTITE II, HEX WSHR SLTD S	3.000 EA
35CB3500A01SP	CONDUIT BOX LID, MACH	1.000 EA
51XN2520A16	SCREW, HEX WS SLT, ZN, 1/4-20 X 1.00	4.000 EA
HW2501D13	KEY, 3/16 SQ X 1.375	1.000 EA

Parts List (continued)		
Part Number	Description	Quantity
HA7000A04	KEY RETAINER 0.625 DIA SHAFTS	1.000 EA
NP0018W	ALUM UL XP CONDUIT BOX NAMEPLATE	1.000 EA
NP0731	NAMEPLATE, CAUTION FOR DC EXPLOSION PROO	1.000 EA
35RK5001	ROCKERARM ASSY X35PM W/TP1515A01 T'STAT	1.000 EA
35FH4005A01SP	IEC FH NO GREASER W/PRIMED	1.000 EA
MG1025G29	WILKOFASST, 789.229, DARK CHARCOAL GRAY	0.014 GA
85XU0407S04	4X1/4 U DRIVE PIN STAINLESS	8.000 EA
HA3104A11	THRUBOLT-5/16-18X10.50 F X	4.000 EA
MG5017	VARNISH - PDG 2500	0.050 GA
MN416A01	TAG-INSTAL-MAINT no wire (1200/bx) 5/18	1.000 EA
LB1119N	WARNING LABEL	1.000 EA
LC0194	CONNECTION LABEL	1.000 EA
NP0727XPSL	SS XP DC UL CSA CC CL-I GP-D CL-II GP-F&	1.000 EA
35PA1007	PKG GRP, PRINT PK1034A06	1.000 EA

DC Motor Performance Data

Record # 1414 - Typical performance - not guaranteed values

Winding: 35WGZ235-R011	Type: 3536P	Enclosure: TEFC
-------------------------------	--------------------	------------------------

Nameplate Data		General Characteristics	
Rated Output (HP)	1	Armature Resistance @ 25°C	0.245 Ω
R.P.M.	1750		
Armature Volts	90	Voltage Constant	50.01 v/krpm
Armature Amps	9.6		
Field Volts		Armature Inductance	3.789 mH
Field Amps		Armature Inertia	30.3419 LI ²
Rating - Duty	40C AMB-CONT		
Power Supply Code	K		

Load Characteristics at 90 Armature Volts

Load Point	1	2	3	4	5	6	7
Armature Amps	1	3.3	4.5	8	10.1	12.3	14.8
R.P.M.	1930	1926	1919	1865	1850	1756	1745
Torque (LB-FT)	0	0.75	1.15	2.25	3	3.75	4.5

Performance Graph at 90.0 Arm V, 1.0HP Typical performance - Not guaranteed values

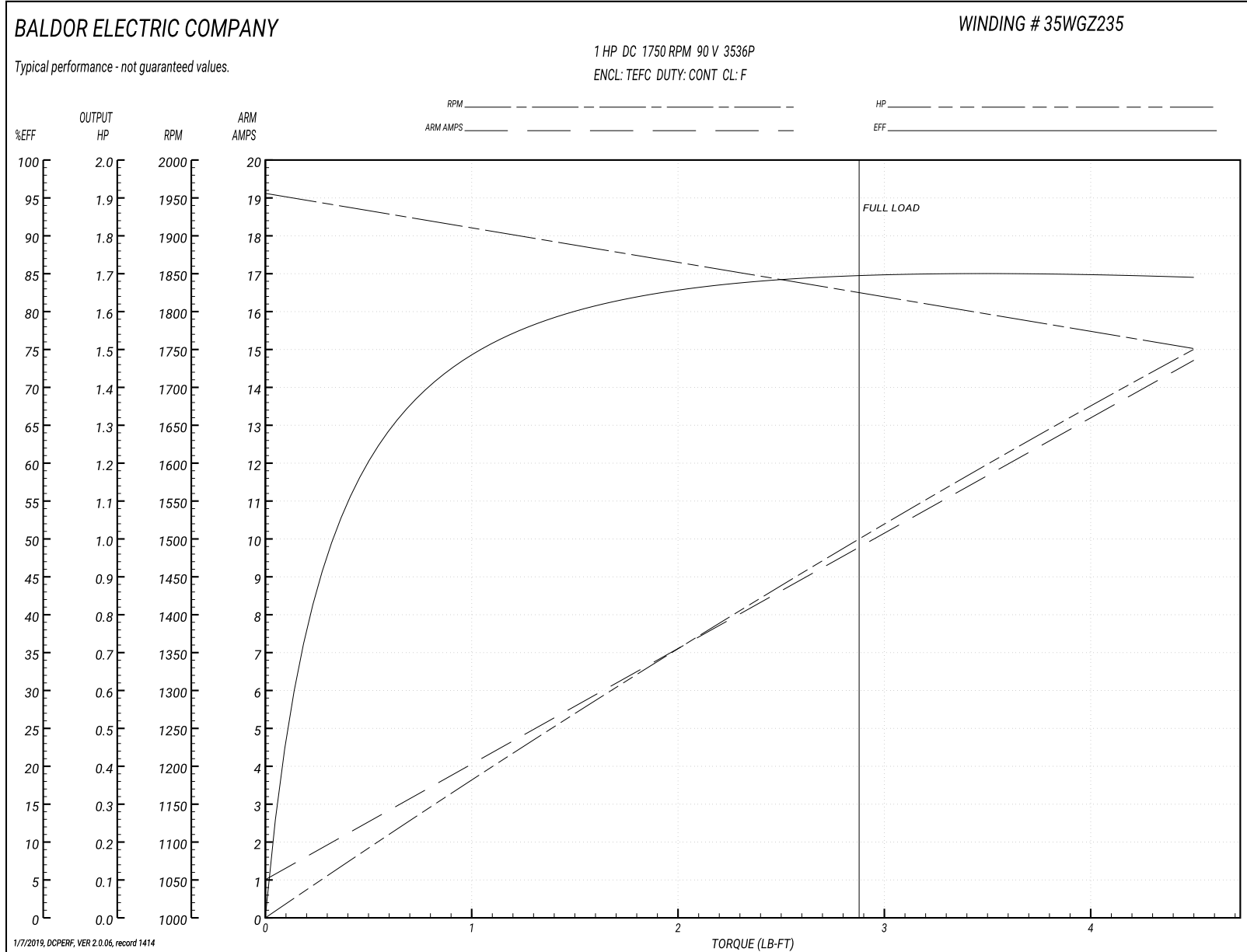

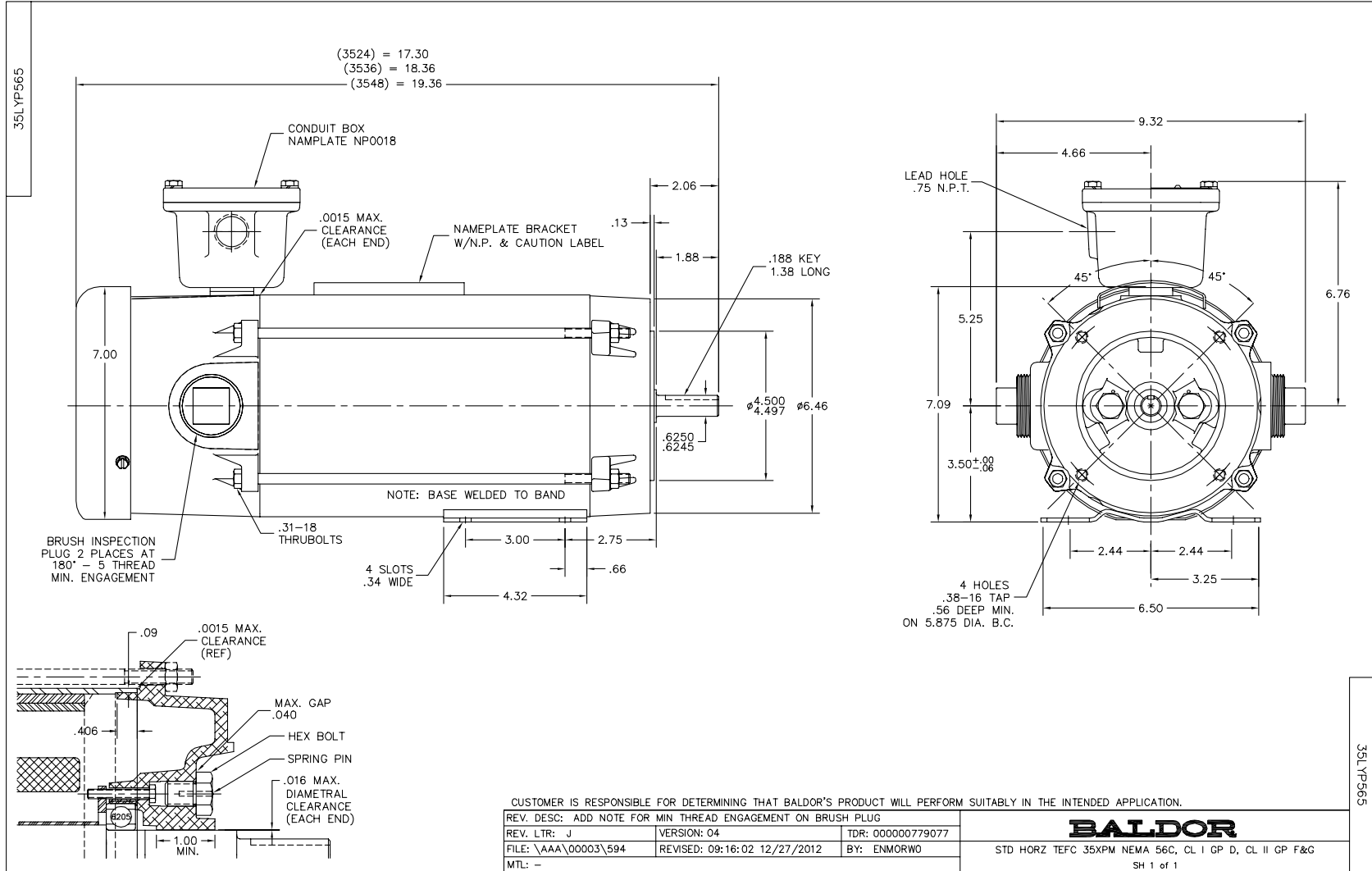

CD0194

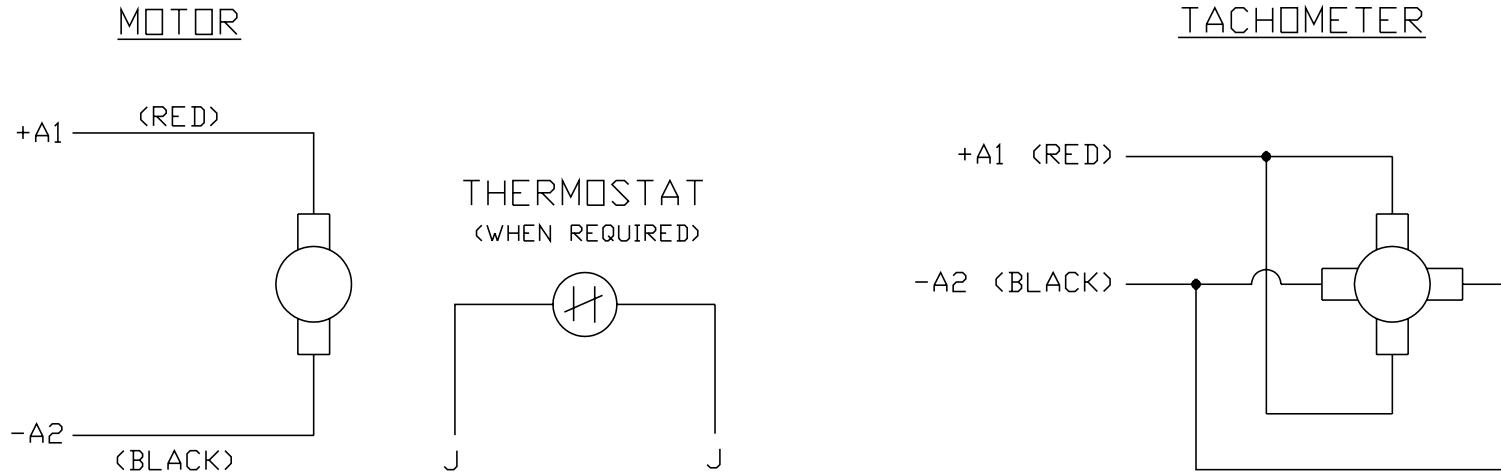

NOTES:

1. CCW ROTATION AS SHOWN FACING COMMUTATOR END. TO REVERSE MOTOR ROTATION OR TACHOMETER OUTPUT POLARITY INTERCHANGE LEADS A1(RED) & A2(BLACK)
2. LEAD COLORS FOR REFERENCE ONLY & NOT SPECIFIED BY THIS DRAWING. LEAD COLORS SPECIFIED BY LAYOUT DRAWING & BILL OF MATERIAL ONLY.

MATL: -			
REV: E	ADDED NOTE "LEAD COLORS FOR REFERENCE ONLY &..."		
761000	SCALE: -	BY: CK	REVISED: 07/28/95
	FILE: AAA00004503		TDR: 0078737

BALDOR ELECTRIC Co.

CD TYPE P DC PERMANENT MAGNET MOTORS AND TACHOMETERS

CD0194