

BALDOR® • RELIANCE 

Product Information Packet

CECP2333T-4

15HP, 1765RPM, 3PH, 60HZ, 254TC, 0944M, TEFC, F

Part Detail							
Revision:	V	Status:	PRD/A	Change #:		Proprietary:	No
Type:	AC	Elec. Spec:	09WGZ914	CD Diagram:	CD0006	Mfg Plant:	
Mech. Spec:	09H180	Layout:	09LYH180	Poles:	04	Created Date:	11-29-2012
Base:	RG	Eff. Date:	07-06-2017	Leads:	3#12		

Specs			
Catalog Number:	CECP2333T-4	Inverter Code:	Inverter Duty
Enclosure:	TEFC	KVA Code:	H
Frame:	254TC	Lifting Lugs:	Standard Lifting Lugs
Frame Material:	Iron	Locked Bearing Indicator:	Locked Bearing
Output @ Frequency:	15.000 HP @ 60 HZ	Motor Lead Quantity/Wire Size:	3 @ 12 AWG
Synchronous Speed @ Frequency:	1800 RPM @ 60 HZ	Motor Lead Exit:	Ko Box
Voltage @ Frequency:	460.0 V @ 60 HZ	Motor Lead Termination:	Flying Leads
XP Class and Group:	None	Motor Type:	0944M
XP Division:	Not Applicable	Mounting Arrangement:	F1
Agency Approvals:	UR	Power Factor:	83
	CSA EEV	Product Family:	Super-E Chemical Processing
	CSA	Pulley End Bearing Type:	Ball
Auxillary Box:	No Auxillary Box	Pulley Face Code:	C-Face
Auxillary Box Lead Termination:	None	Pulley Shaft Indicator:	Standard
Base Indicator:	Rigid	Rodent Screen:	None
Bearing Grease Type:	Polyrex EM (-20F +300F)	Shaft Extension Location:	Pulley End
Blower:	None	Shaft Ground Indicator:	No Shaft Grounding
Constant Torque Speed Range:	1.2	Shaft Rotation:	Reversible

Current @ Voltage:	18.100 A @ 460.0 V	Shaft Slinger Indicator:	Shaft Slinger
Design Code:	A	Speed Code:	Single Speed
Drip Cover:	No Drip Cover	Motor Standards:	NEMA
Duty Rating:	CONT	Starting Method:	Direct on line
Electrically Isolated Bearing:	Not Electrically Isolated	Thermal Device - Bearing:	NONE (OLD)
Feedback Device:	NO FEEDBACK	Thermal Device - Winding:	None
Front Face Code:	Standard	Vibration Sensor Indicator:	No Vibration Sensor
Front Shaft Indicator:	None	Winding Thermal 1:	None
Heater Indicator:	No Heater	Winding Thermal 2:	None
Insulation Class:	F	XP Temp Code:	T3C

Nameplate NP3241											
CAT.NO.	CECP2333T-4	P/N		ENCLOSURE	TEFC						
SPEC.	09H180Z914	CC	010A	FRAME	254TC	S/N					
HP	15	CLASS	F	HZ	60	DES	A				
RPM	1765	RPM MAX	2700	PH	3	KVA-CODE	H				
VOLT	460	MOTOR WEIGHT	314								
AMP	18.1	SER.F.	1.15	PF	83	ODE BRG	6309	DE BRG	6309		
RATING	40C AMB-CONT	NEMA-NOM-EFF	92.4	GREASE	POLYREX EM						
				INV.TYPE	PWM						
TEMP CODE	T3C	INVERTER-TEMP-CODE	180								
TEMP =	160	C HP FR	60	C HP TO	90						
CT HZ FROM	1.2	CT HZ TO	60								
HTR-VOLTS		HTR-AMPS		HTR-WATTS		MAX. SPACE HEATER TEMP.		VT HZ FROM	0	VT HZ TO	60

Parts List		
Part Number	Description	Quantity
SA255010	SA 09H180Z914	1.000 EA
RA241814	RA 09H180Z914	1.000 EA
09CB1002A12P	KOBX W/1.25 NPT LEAD HOLE & 2.38 MTG HOL	1.000 EA
09GS1010	GASKET, DWG, LEADWIRE SEPERATOR	1.000 EA
10XN2520K12	1/4-20 X.75 GRD 5	2.000 EA
HW1001A25	LOCKWASHER 1/4, ZINC PLT .493 OD, .255 I	2.000 EA
WD1000B16	T&B CX70TN TERMINAL	1.000 EA
10XN2520K08	1/4-20 X .50 GRADE #5, STL, ZINC PLATE	1.000 EA
HW1001A25	LOCKWASHER 1/4, ZINC PLT .493 OD, .255 I	1.000 EA
HA3400A39	STUD- 3/8-16 X 6.44 OAL HEX	4.000 EA
HW1001A38	LOCKWASHER 3/8, ZINC PLT .688 OD, .382 I	4.000 EA
HA4017A08	.125X3.50 GREASER EXTEN.	1.000 EA
HA4017A02	.125X2.50 GREASER EXTENS.F/S	1.000 EA
HW4019A01	PIPE COUPLING 1/8 NPT,STEEL,ZINC COATING	1.000 EA
HW5100A11	W3917-042 WVY WSHR (WB)	1.000 EA
10XN2520K36	1/4-20 X 2.25" HX HD SCRWGRADE 5, ZINC P	2.000 EA
09FH1000P	FAN COVER, CAST W/EPOXY PRIMER	1.000 EA
09EP1300A12P	ENDPLATE, MACH EPOXY PRIMER	1.000 EA
10XN3816K28	3/8-16 X 1.75 HEX HD CAP SCREW, GRADE 5	4.000 EA
HW1001A38	LOCKWASHER 3/8, ZINC PLT .688 OD, .382 I	4.000 EA
10XN2520K36	1/4-20 X 2.25" HX HD SCRWGRADE 5, ZINC P	4.000 EA
HW1001A38	LOCKWASHER 3/8, ZINC PLT .688 OD, .382 I	4.000 EA
XY3816A12	3/8-16 FINISHED NUT	4.000 EA
HW4600B44	V-RING SLINGER 1.500 X 1.810 X .28 VITON	1.000 EA

Parts List (continued)		
Part Number	Description	Quantity
HA1005A26	SLINGER, OD 3.00, ID 1.75, 309 BRG	1.000 EA
12CB1503P	CONDUIT BOX LID, CAST W/EPOXY PRIMER	1.000 EA
12GS1002	GASKET, CONDUIT BOX LID, NEOP	1.000 EA
10XN3118K16	5/16-18 X 1' GRADE #5, STL, ZINC PLATE	2.000 EA
HW1001A31	LOCKWASHER 5/16, ZINC PLT.591 OD, .319 I	2.000 EA
HW2501G25	KEY, 3/8 SQ X 2.875	1.000 EA
MJ5001A27	32220KN GRAY SEALER *MIN BUY 4 QTS=1GAL	0.031 QT
MJ5001A14	DYNAPRO SEALANT, CP MTR VC#2508050 (603	0.023 EA
LB1115N	LABEL,LIFTING DEVICE (ON ROLLS)	1.000 EA
09EP1118A05GP6	FREP MACH, 309 BRG. EPOXY PRIMER	1.000 EA
MN416A01	TAG-INSTAL-MAINT no wire (1200/bx) 5/18	1.000 EA
LB1002N	LABEL,MARINE DUTY (ON ROLLS)	1.000 EA
HW4500A17	317400 ALEMITE GREASE RELIEF	1.000 EA
HW4500A21	1618BALEMITE FITTING 825 UNIVERSAL	1.000 EA
HA4054	SHORT T-DRAIN FITTING, .125" N.P.T.	1.000 EA
HA4051A00	PLASTIC CAP FOR GREASE FITTING	1.000 EA
MJ1000A02	GREASE, POLYREX EM EXXON (USe 4824-15A)	0.080 LB
HW4500A03	GREASE FITTING, .125 NPT 1610(ALEMITE) 8	1.000 EA
HW4500A17	317400 ALEMITE GREASE RELIEF	1.000 EA
HA4054	SHORT T-DRAIN FITTING, .125" N.P.T.	1.000 EA
HA4051A00	PLASTIC CAP FOR GREASE FITTING	1.000 EA
09FN3001D01SP	EXTERNAL FAN, PLASTIC	1.000 EA
HW2500A25	WOODRUFF KEY USA #1008 #BLOW CARBON STEE	1.000 EA
51XB1214A20	12-14X1.25 HXWSSLD SERTYB	1.000 EA

Product Information Packet: CEC2333T-4 - 15HP,1765RPM,3PH,60HZ,254TC,0944M,TEFC,F

MG1025N19	WILKOFAST, 778.50, RELIANCE BLUE-GREEN	0.050 GA
85XU0407S04	4X1/4 U DRIVE PIN STAINLESS	2.000 EA
LB1119N	WARNING LABEL	1.000 EA
LC0006	CONNECTION LABEL	1.000 EA
NP3241	SS SUPER-E INV UL CSA-EEV PREM CC	1.000 EA
40PA1005	PACKAGING GROUP, 09 STD	1.000 EA
LB1449	DIV-2/NEC WARNING LABEL	1.000 EA

AC Induction Motor Performance Data

Record # 47166 - Typical performance - not guaranteed values

Winding: 09WGZ914-R021	Type: 0944M	Enclosure: TEFC
-------------------------------	--------------------	------------------------

Nameplate Data				460 V, 60 Hz: High Voltage Connection	
Rated Output (HP)	15			Full Load Torque	44.5 LB-FT
Volts	460			Start Configuration	direct on line
Full Load Amps	18.1			Breakdown Torque	153 LB-FT
R.P.M.	1765			Pull-up Torque	69.5 LB-FT
Hz	60	Phase	3	Locked-rotor Torque	86.5 LB-FT
NEMA Design Code	A	KVA Code	H	Starting Current	127 A
Service Factor (S.F.)	1.15			No-load Current	7.56 A
NEMA Nom. Eff.	92.4	Power Factor	83	Line-line Res. @ 25°C	0.59555 Ω
Rating - Duty	40C AMB-CONT			Temp. Rise @ Rated Load	54°C
S.F. Amps				Temp. Rise @ S.F. Load	67°C
				Locked-rotor Power Factor	33.1
				Rotor inertia	1.92 LB-FT ²

Load Characteristics 460 V, 60 Hz, 15 HP

% of Rated Load	25	50	75	100	125	150	S.F.
Power Factor	45	69	79	83	85	87	84
Efficiency	88.2	92.2	92.7	92.4	91.5	90.4	91.9
Speed	1791.3	1783.1	1774	1765.2	1754.6	1743.1	1759
Line amperes	8.62	11	14.5	18.2	22.6	26.9	20.8

Performance Graph at 460V, 60Hz, 15.0HP Typical performance - Not guaranteed values

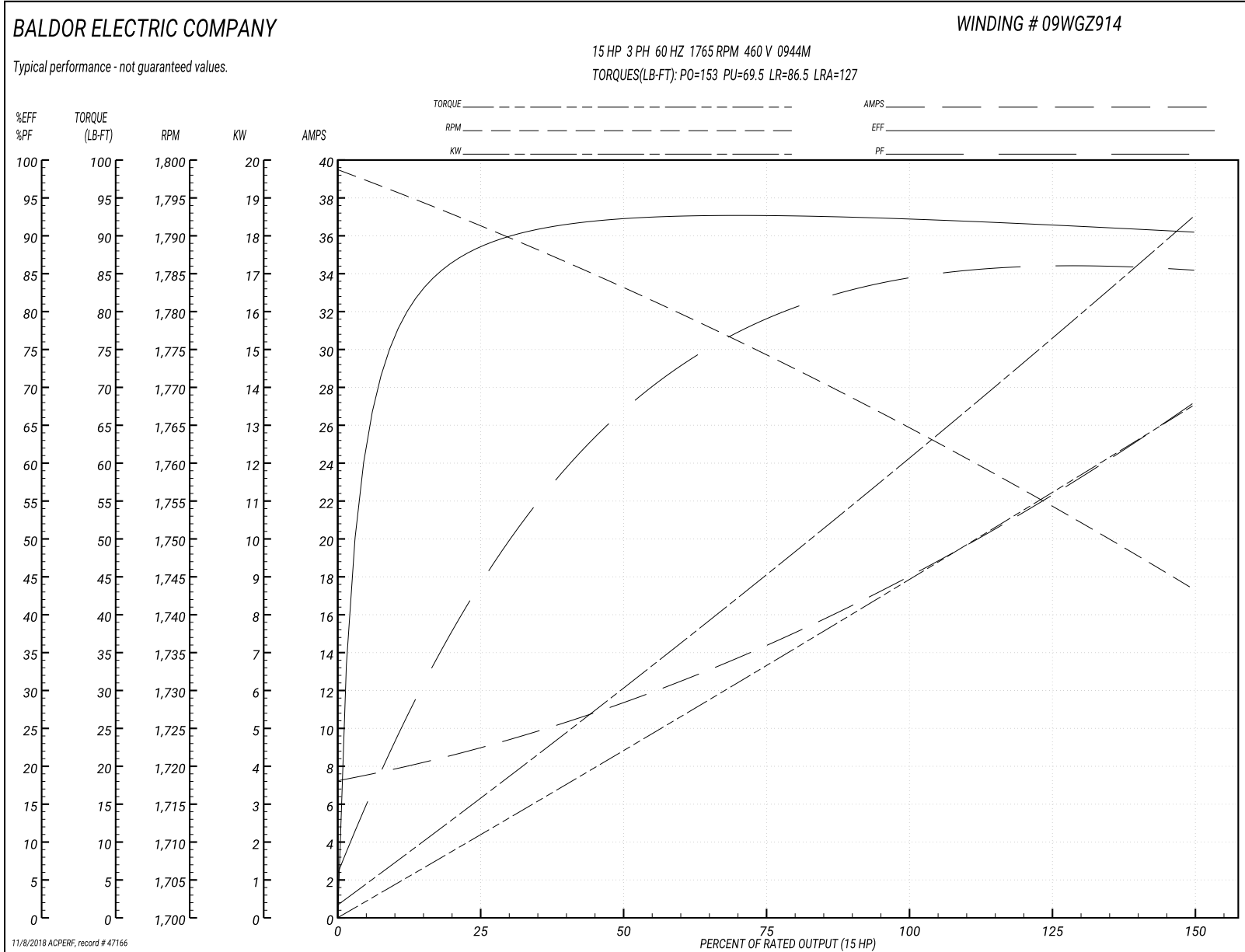

09LYH180

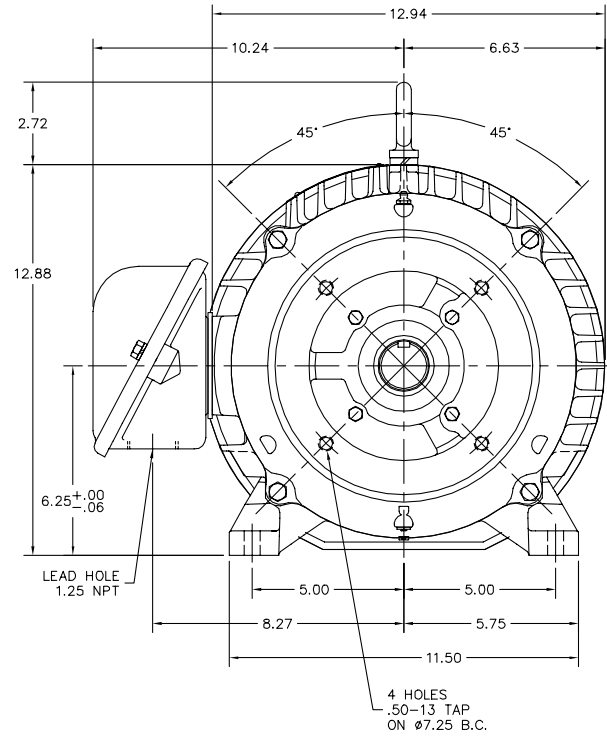
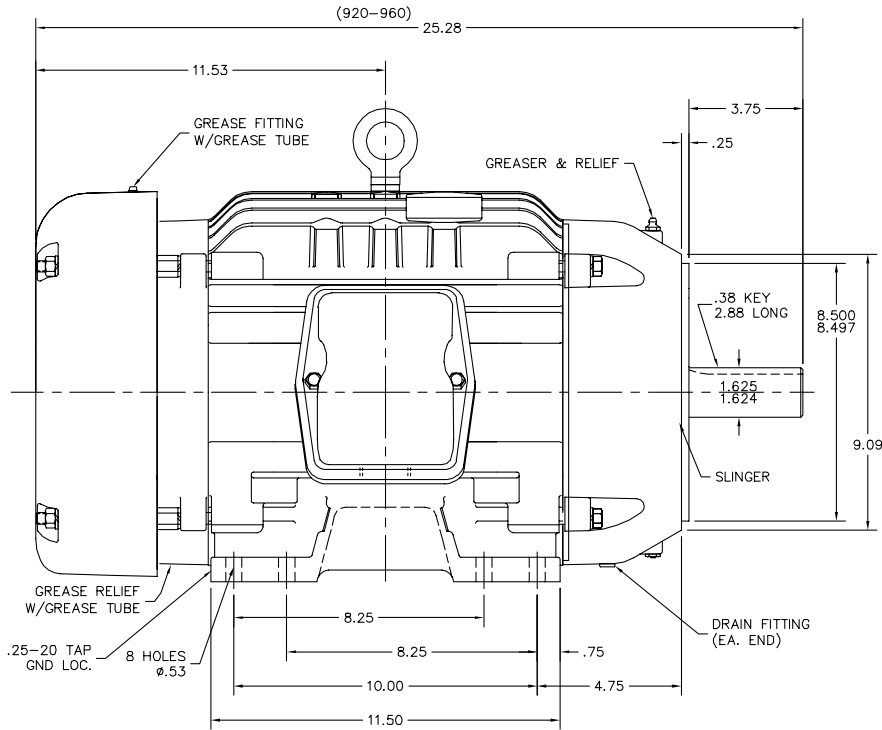

08LHA160

CUSTOMER IS RESPONSIBLE FOR DETERMINING THAT BALDOR'S PRODUCT WILL PERFORM SUITABLY IN THE INTENDED APPLICATION.

REV. DESC: REMOVE LOCKNUT & ADDED GND HOLE TAP SIZE		
REV. LTR: J	VERSION: 09	TDR: 000000955850
FILE: \AAA\00137\913	REVISED: 01:06:30 12/07/2015	BY: ENNINDO
MTL: -		

BALDOR
 HORZ TEFC 254-6TC ECP W/309 BRGS
 SH 1 of 1

CD0006

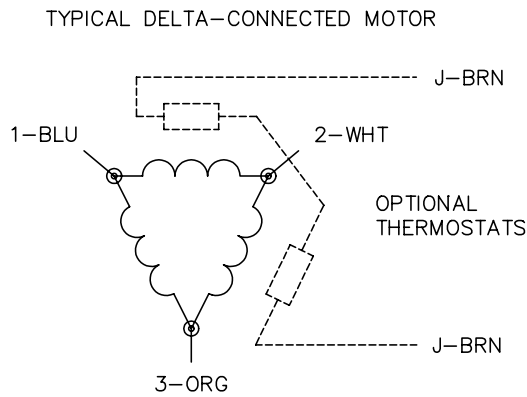
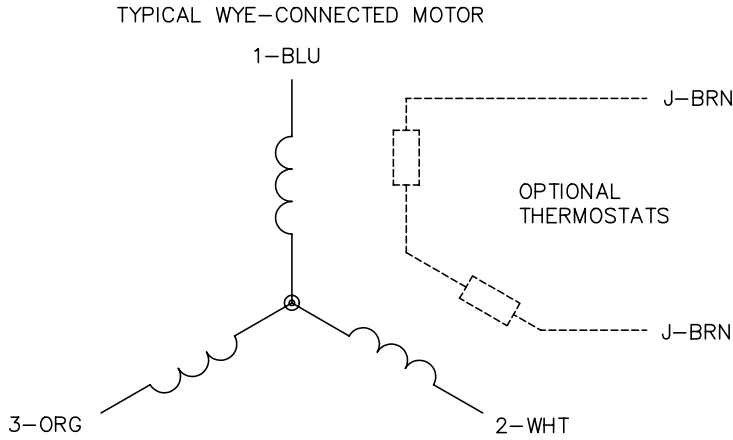

NOTES:

1. THREE LEAD MOTOR MAY BE EITHER WYE CONNECTED OR DELTA CONNECTED.
2. INTERCHANGE ANY TWO LINE LEADS TO REVERSE ROTATION.
3. OPTIONAL THERMOSTATS ARE PROVIDED WHEN SPECIFIED.
4. ACTUAL NUMBER OF INTERNAL PARALLEL CIRCUITS MAY VARY.
5. LEAD COLORS ARE OPTIONAL. LEADS MUST BE NUMBERED AS SHOWN.

REV. DESC: REVISE TO SHOW OPTIONAL COLORS			
REV. LTR: D	BY: JLP	REVISED: 01/21/99 4:02	TDR: 0171435
9000D		FILE: AAA00005141	MDL: -
		MTL: -	

BALDOR ELECTRIC Co.

3PH, SV, 3 LEADS, WYE OR DELTA CONNECTED

CD0006

Marketing maintained PDF of MN416:

<http://www.baldor.com/support/Literature/Load.ashx/MN416?ManNumber=MN416>