

BALDOR® • RELIANCE 

Product Information Packet

CECP84109T-4

40HP,3530RPM,3PH,60HZ,324TSC,1256M,TEFC

Part Detail							
Revision:	M	Status:	PRD/A	Change #:		Proprietary:	No
Type:	AC	Elec. Spec:	12WGY667	CD Diagram:	CD0006	Mfg Plant:	
Mech. Spec:	12E919	Layout:	12LYE919	Poles:	02	Created Date:	05-02-2013
Base:	RG	Eff. Date:	12-12-2017	Leads:	3#8		

Specs			
Catalog Number:	CECP84109T-4	Insulation Class:	F
Enclosure:	TEFC	Inverter Code:	Inverter Duty
Frame:	324TSC	KVA Code:	G
Frame Material:	Iron	Lifting Lugs:	Standard Lifting Lugs
Output @ Frequency:	40.000 HP @ 60 HZ	Locked Bearing Indicator:	Locked Bearing
Synchronous Speed @ Frequency:	3600 RPM @ 60 HZ	Motor Lead Quantity/Wire Size:	3 @ 8 AWG
Voltage @ Frequency:	460.0 V @ 60 HZ	Motor Lead Exit:	Ko Box
XP Class and Group:	CLI GP A,B,C,D	Motor Lead Termination:	Ring Terminals
XP Division:	Division II	Motor Type:	1256M
Agency Approvals:	CSA EEV	Mounting Arrangement:	F1
	UR	Power Factor:	91
	CSA	Product Family:	Chem Process S/P 32-8 IEEE 841
	CCSA US	Pulley End Bearing Type:	Ball
Auxillary Box:	No Auxillary Box	Pulley Face Code:	Standard
Auxillary Box Lead Termination:	None	Pulley Shaft Indicator:	Standard
Base Indicator:	Rigid	Rodent Screen:	None
Bearing Grease Type:	Polyrex EM (-20F +300F)	Shaft Extension Location:	Pulley End
Blower:	None	Shaft Ground Indicator:	No Shaft Grounding

Constant Torque Speed Range:	6	Shaft Rotation:	Reversible
Current @ Voltage:	44.000 A @ 460.0 V	Shaft Slinger Indicator:	No Slinger
Design Code:	B	Speed Code:	Single Speed
Drip Cover:	No Drip Cover	Motor Standards:	NEMA
Duty Rating:	CONT	Starting Method:	Direct on line
Electrically Isolated Bearing:	Not Electrically Isolated	Thermal Device - Bearing:	NONE (OLD)
Feedback Device:	NO FEEDBACK	Thermal Device - Winding:	None
Front Face Code:	Standard	Vibration Sensor Indicator:	No Vibration Sensor
Front Shaft Indicator:	None	Winding Thermal 1:	None
Heater Indicator:	No Heater	Winding Thermal 2:	None
		XP Temp Code:	T3

Nameplate NP3190											
STK.NO.	CECP84109T-4		P/N			ENCLOSURE	TEFC				
SPEC.	12E919Y667		CC	010A	FRAME	324TSC		S/N			
HP	40		CLASS	F	HZ	60		ODE BRG	6312	DE BRG	6312
RPM	3545	RPM MAX	5400		PH	3	DES	B		D.E. BRG.	60BC03X30X
VOLT	460		KVA-CODE	G		O.D.E. BRG.	60BC03X30X				
AMP	44		MOTOR WEIGHT	587		GREASE	POLYREX EM				
RATING	40C AMB-CONT		MAX. KVAR	4		BLANK					
NEMA-NOM-EFF	92.4	# OF ROTOR BARS	28		SER.F.	1.15		IP	56		
G.MIN.EFF	91	# OF STATOR SLOTS	36		PF	91		INV.TYPE	PWM		
TEMP CODE	T3		INVERTER-TEMP-CODE	200							
TEMP =	200		C HP FR	60	C HP TO	90					
CT HZ FROM	6	CT HZ TO	60								
HTR-VOLTS			HTR-AMPS			HTR-WATTS			MAX. SPACE HEATER TEMP.		
								VT HZ FROM	3	VT HZ TO	60

Parts List		
Part Number	Description	Quantity
SA262769	SA 12E919Y667	1.000 EA
RA249493	RA 12E919Y667	1.000 EA
37FN3002B04	EXFN, PLASTIC, 7.50 OD, 2.003 ID	1.000 EA
WD1000B19	TERMINAL BURNDY L250HP	1.000 EA
10XN3816K08	3/8-16 X .50 HEX HD CAP SCREW GRADE 5	1.000 EA
10CB1000A04P	CONDUIT BOX, MACH W/EPOXY PRIMER	1.000 EA
09GS1010	GASKET, DWG, LEADWIRE SEPERATOR	1.000 EA
10XN3118K16	5/16-18 X 1' GRADE #5, STL, ZINC PLATE	4.000 EA
HW1001A31	LOCKWASHER 5/16, ZINC PLT.591 OD, .319 I	4.000 EA
WD1000B16	T&B CX70TN TERMINAL	1.000 EA
10XN2520K06	1/4-20 X 3/8" HX HD SCREWGRADE 5, ZINC P	1.000 EA
HW1001A25	LOCKWASHER 1/4, ZINC PLT .493 OD, .255 I	1.000 EA
HA3400A32	STUD, 1/2-13 X 7.38	4.000 EA
HW1001A50	LOCKWASHER 1/2, ZINC PLT.,.879 OD, .509 I	4.000 EA
HA4002A03	#304 S.S. DRAIN FITTING, .125 NPT (.44 H	1.000 EA
HW4500A20	1/8NPT SL PIPE PLUG	1.000 EA
HA4017A01	1/8 X 4 GREASE EXT (F/S)	1.000 EA
HA4017A11	1/8 X 2.75 GREASE EXT (F/S)	1.000 EA
HW4019A01	PIPE COUPLING 1/8 NPT,STEEL,ZINC COATING	1.000 EA
HA4002A03	#304 S.S. DRAIN FITTING, .125 NPT (.44 H	1.000 EA
HW4601A55	INPRO/SEAL #1698-A-M0022-0 VBXX 312 BRG/	1.000 EA
HW5100A15	W4997-050 WVY WSHR (WB)	1.000 EA
10XN3118K40	5/16-18 X 2.50" HEX HD, GRADE 5	4.000 EA
12EP1105A14P	PU EP MACH FOR INPRO SEAL W/EPOXY PRIMER	1.000 EA

Parts List (continued)		
Part Number	Description	Quantity
10XN5013K28	1/2-13 X 1.75 HEX HEAD MACH SCREW,GRAD	4.000 EA
HW1001A50	LOCKWASHER 1/2, ZINC PLT.,.879 OD, .509 I	4.000 EA
HW4601A55	INPRO/SEAL #1698-A-M0022-0 VBXX 312 BRG/	1.000 EA
10XN3118K40	5/16-18 X 2.50" HEX HD, GRADE 5	4.000 EA
XY5013A12	NUT,1/2-13,HEX,STEEL,ZINCPLATED	4.000 EA
HW1001A50	LOCKWASHER 1/2, ZINC PLT.,.879 OD, .509 I	4.000 EA
10CB1503A01P	CONDUIT BOX LIPPED LID, MACH W/EPXY PRMR	1.000 EA
14GS1003	GASKET CONDUIT BOX LID, NEOP	1.000 EA
10XN2520K16	1/4-20 X 1" HX HD SCRW GRADE 5, ZINC P	4.000 EA
HW1001A25	LOCKWASHER 1/4, ZINC PLT .493 OD, .255 I	4.000 EA
MJ5004A59	ADHESIVE LOCTITE #401 SURFACE INSENSITIV	0.010 EA
HW2501H18	KEY, 1/2 SQ X 2.000	1.000 EA
MJ5001A27	32220KN GRAY SEALER *MIN BUY 4 QTS=1GAL	0.031 QT
MJ5001A14	DYNAPRO SEALANT, CP MTR VC#2508050 (603	0.029 EA
LB1115N	LABEL,LIFTING DEVICE (ON ROLLS)	1.000 EA
12EP1111A02GP6	FR ENDPLATE, MACH W/EPOXY PRIMER & RELIA	1.000 EA
MN416A01	TAG-INSTAL-MAINT no wire (1200/bx) 5/18	1.000 EA
HW4500A21	1618BALEMITE FITTING 825 UNIVERSAL	1.000 EA
HA4051A00	PLASTIC CAP FOR GREASE FITTING	1.000 EA
HW4500A17	317400 ALEMITE GREASE RELIEF	1.000 EA
MJ1000A02	GREASE, POLYREX EM EXXON (USe 4824-15A)	0.200 LB
HW4500A03	GREASE FITTING, .125 NPT 1610(ALEMITE) 8	1.000 EA
HA4051A00	PLASTIC CAP FOR GREASE FITTING	1.000 EA
HW4500A17	317400 ALEMITE GREASE RELIEF	1.000 EA

Product Information Packet: CEC84109T-4 - 40HP,3530RPM,3PH,60HZ,324TSC,1256M,TEFC

HW2500A25	WOODRUFF KEY USA #1008 #BLOW CARBON STEE	1.000 EA
51XB1214A20	12-14X1.25 HXWSSLD SERTYB	1.000 EA
12FH1002A15GP6	FAN COVER, MACH, W/PRIMER W/MG1025N19	1.000 EA
MG1025N19	WILKOFASST, 778.50, RELIANCE BLUE-GREEN	0.080 GA
85XU0407S04	4X1/4 U DRIVE PIN STAINLESS	4.000 EA
LB1449	DIV-2/NEC WARNING LABEL	1.000 EA
WD1000B48	T&B D73, RING TERMINAL 8 AWG 3/8 STUD	3.000 EA
LB1119N	WARNING LABEL	1.000 EA
LB1417	LABEL CARTON 6X4 PERFORATED BLANK ROLLS	1.000 EA
LC0006	CONNECTION LABEL	1.000 EA
NP3190	SS IEEE841 INV DIV-2 UL CSA-C US EEV	1.000 EA
12PA1000	PACKAGING GROUP PRINT PK1024A06	1.000 EA

AC Induction Motor Performance Data

Record # 47225 - Typical performance - not guaranteed values

Winding: 12WGY667-R012	Type: 1256M	Enclosure: TEFC
-------------------------------	--------------------	------------------------

Nameplate Data				460 V, 60 Hz: Single Voltage Motor	
Rated Output (HP)	40			Full Load Torque	59.1 LB-FT
Volts	460			Start Configuration	direct on line
Full Load Amps	44			Breakdown Torque	194 LB-FT
R.P.M.	3545			Pull-up Torque	63.8 LB-FT
Hz	60	Phase	3	Locked-rotor Torque	80.9 LB-FT
NEMA Design Code	B	KVA Code	G	Starting Current	284 A
Service Factor (S.F.)	1.15			No-load Current	9.79 A
NEMA Nom. Eff.	92.4	Power Factor	91	Line-line Res. @ 25°C	0.154 Ω
Rating - Duty	40C AMB-CONT			Temp. Rise @ Rated Load	67°C
S.F. Amps				Temp. Rise @ S.F. Load	83°C
				Locked-rotor Power Factor	20.5
				Rotor inertia	4.38 LB-FT ²

Load Characteristics 460 V, 60 Hz, 40 HP

% of Rated Load	25	50	75	100	125	150	S.F.
Power Factor	72	86	91	91	91	90	91
Efficiency	86.9	91.6	92.5	92.4	91.9	91	92.4
Speed	3588	3575	3561	3545	3529	3510	3526
Line amperes	15.1	23.7	33.6	44.3	56	68.5	51.2

Performance Graph at 460V, 60Hz, 40.0HP Typical performance - Not guaranteed values

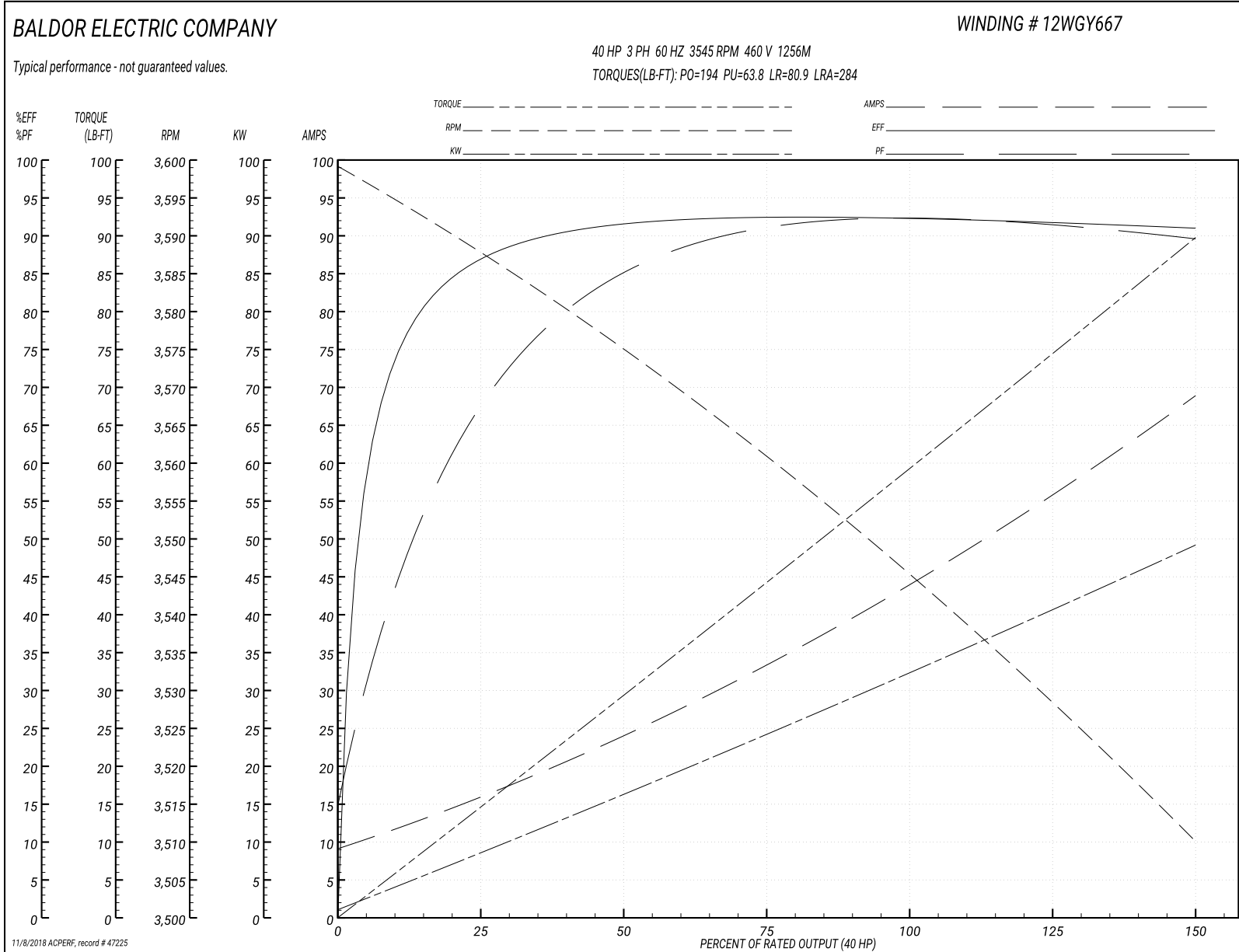

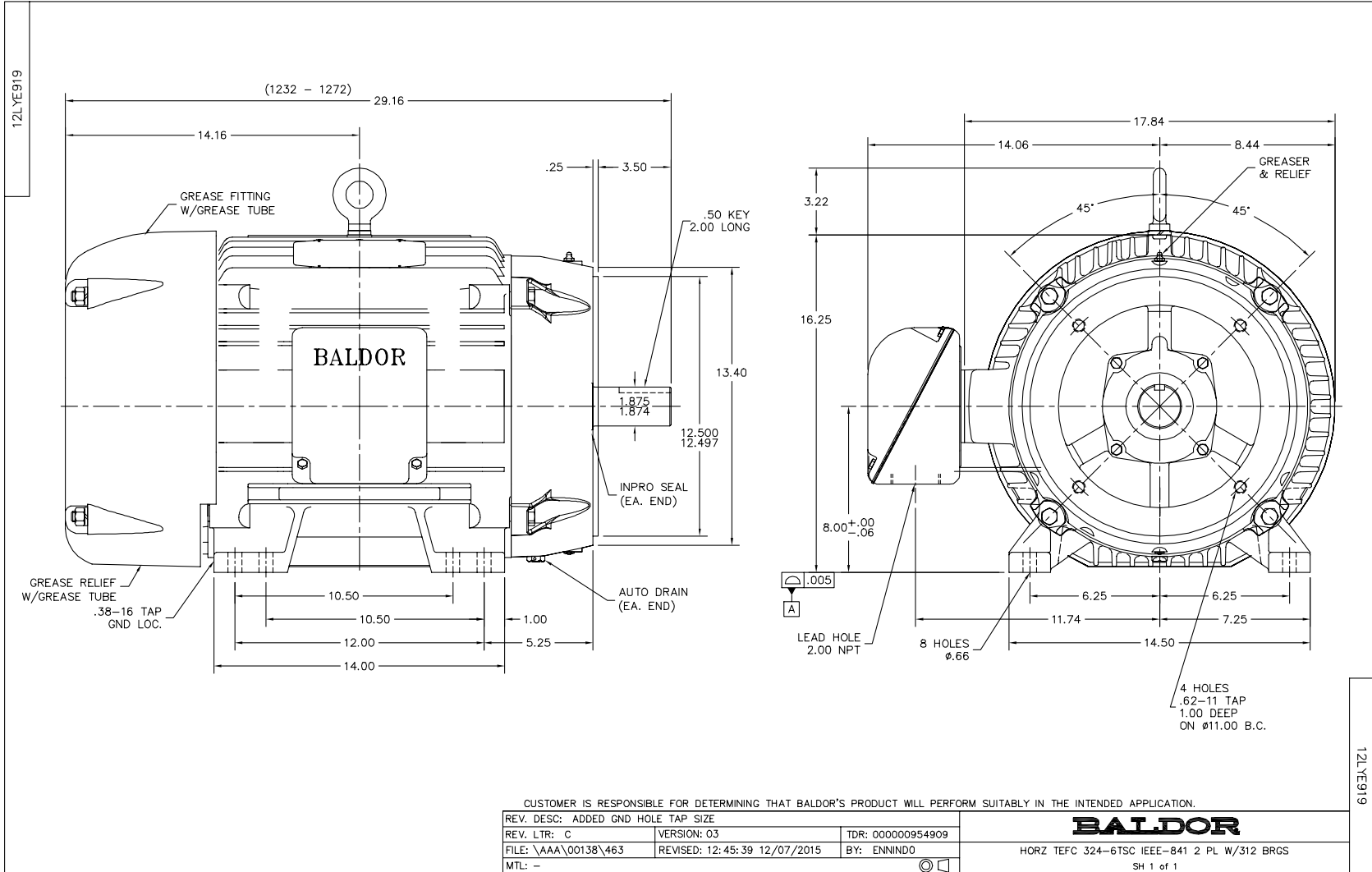

CD0006

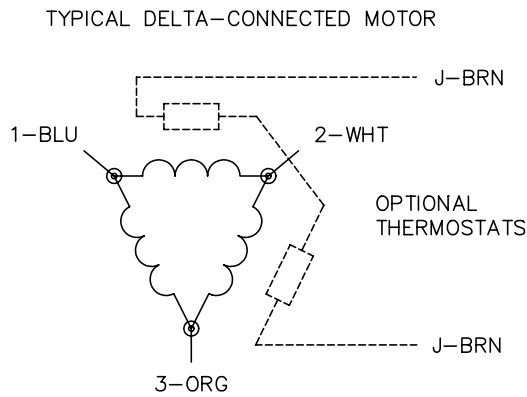
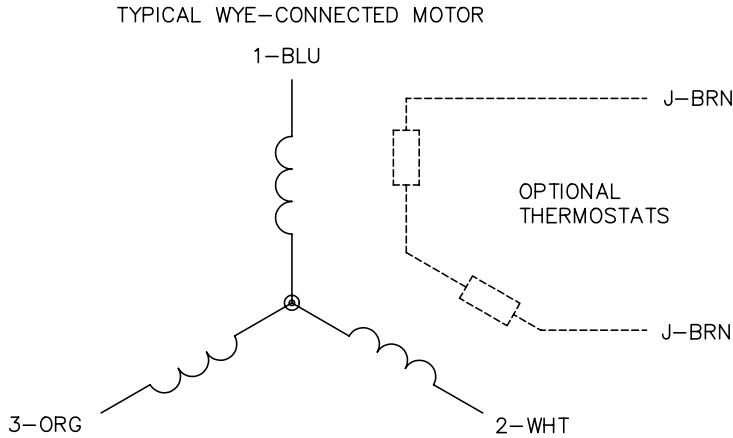

NOTES:

1. THREE LEAD MOTOR MAY BE EITHER WYE CONNECTED OR DELTA CONNECTED.
2. INTERCHANGE ANY TWO LINE LEADS TO REVERSE ROTATION.
3. OPTIONAL THERMOSTATS ARE PROVIDED WHEN SPECIFIED.
4. ACTUAL NUMBER OF INTERNAL PARALLEL CIRCUITS MAY VARY.
5. LEAD COLORS ARE OPTIONAL. LEADS MUST BE NUMBERED AS SHOWN.

REV. DESC: REVISE TO SHOW OPTIONAL COLORS			
REV. LTR: D	BY: JLP	REVISED: 01/21/99 4:02	TDR: 0171435
9000D		FILE: AAA00005141	MDL: -
		MTL: -	

BALDOR ELECTRIC Co.

3PH, SV, 3 LEADS, WYE OR DELTA CONNECTED

CD0006

Marketing maintained PDF of MN416:

<http://www.baldor.com/support/Literature/Load.ashx/MN416?ManNumber=MN416>