

BALDOR® • RELIANCE 

Product Information Packet

CEM7075T

3HP,3450RPM,3PH,60HZ,145TC,3532M,XPFC,F1

Part Detail							
Revision:	P	Status:	PRD/A	Change #:		Proprietary:	No
Type:	AC	Elec. Spec:	35WGQ060	CD Diagram:	CD0005	Mfg Plant:	
Mech. Spec:	35J610	Layout:	35LYJ610	Poles:	02	Created Date:	06-11-2010
Base:	RG	Eff. Date:	06-11-2018	Leads:	9#18		

Specs			
Catalog Number:	CEM7075T	Insulation Class:	B
Enclosure:	XPFC	Inverter Code:	Not Inverter
Frame:	145TC	KVA Code:	L
Frame Material:	Steel	Lifting Lugs:	No Lifting Lugs
Output @ Frequency:	3.000 HP @ 60 HZ	Locked Bearing Indicator:	Locked Bearing
Synchronous Speed @ Frequency:	3600 RPM @ 60 HZ	Motor Lead Quantity/Wire Size:	9 @ 18 AWG
Voltage @ Frequency:	460.0 V @ 60 HZ	Motor Lead Exit:	Ko Box
	230.0 V @ 60 HZ	Motor Lead Termination:	Flying Leads
XP Class and Group:	CLI GP D	Motor Type:	3532M
XP Division:	Division I	Mounting Arrangement:	F1
Agency Approvals:	CSA	Power Factor:	92
	CSA EEV	Product Family:	Hazardous Location Motor
	UR	Pulley End Bearing Type:	Ball
Auxillary Box:	No Auxillary Box	Pulley Face Code:	C-Face
Auxillary Box Lead Termination:	None	Pulley Shaft Indicator:	Standard
Base Indicator:	Rigid	Rodent Screen:	None
Bearing Grease Type:	Polyrex EM (-20F +300F)	RoHS Status:	ROHS COMPLIANT
Blower:	None	Shaft Extension Location:	Pulley End

Current @ Voltage:	3.600 A @ 460.0 V	Shaft Ground Indicator:	No Shaft Grounding
	7.200 A @ 230.0 V	Shaft Rotation:	Reversible
	7.900 A @ 208.0 V	Shaft Slinger Indicator:	No Slinger
Design Code:	B	Speed Code:	Single Speed
Drip Cover:	No Drip Cover	Motor Standards:	NEMA
Duty Rating:	CONT	Starting Method:	Direct on line
Electrically Isolated Bearing:	Not Electrically Isolated	Thermal Device - Bearing:	NONE (OLD)
Feedback Device:	NO FEEDBACK	Thermal Device - Winding:	Normally Closed Thermostat
Front Face Code:	Standard	Vibration Sensor Indicator:	No Vibration Sensor
Front Shaft Indicator:	None	Winding Thermal 1:	None
Heater Indicator:	No Heater	Winding Thermal 2:	None
		XP Temp Code:	T3C

Nameplate NP0015XPSLEV	
NO.	<input type="text"/> CC 010A
SER.	<input type="text"/>
SPEC.	35J610Q060G1
CAT.NO.	CEM7075T
HP	3 T. CODE T3C
VOLTS	230/460
AMPS	7.2/3.6
RPM	3450
HZ	60 PH 3 CL B
SER.F.	1.00 DES B CODE L
RATING	40C AMB-CONT
FRAME	145TC NEMA-NOM-EFF 86.5
USABLE AT 208V	7.9 PF 92
BLANK	<input type="text"/>

Parts List		
Part Number	Description	Quantity
SA198107	SA 35J610Q060G1	1.000 EA
RA185474	RA 35J610Q060G1	1.000 EA
35CB3001A02SP	EXPL PROOF CONDUIT BOX, 3/4"PIPE TAP LEA	1.000 EA
11XW1032G06	10-32 X .38, TAPTITE II, HEX WSHR SLTD U	1.000 EA
HW3001B01	BRASS CUP WASHER, FOR #10 SCREW	1.000 EA
35EP3700A01SP	FR ENDPLATE, XPFC	1.000 EA
HW5100A03	WAVY WASHER (W1543-017)	1.000 EA
35EP3702A01SP	PU EP-205 BRG-35X-56C-143-5TC	1.000 EA
51XN1032A20	10-32 X 1 1/4 HX WS SL SR	2.000 EA
HA3013A01	1/2-20X5/8 SPL.HX BOLT	2.000 EA
HW3021C06	3/32 DI X .625 PIN (F/S)	2.000 EA
XY3118A12	5/16-18 HEX NUT DIRECTIONAL SERRATION	4.000 EA
35FH4005A01SP	IEC FH NO GREASER W/PRIMED	1.000 EA
51XW1032A06	10-32 X .38, TAPTITE II, HEX WSHR SLTD S	3.000 EA
35CB3500A01SP	CONDUIT BOX LID, MACH	1.000 EA
51XN2520A16	SCREW, HEX WS SLT, ZN, 1/4-20 X 1.00	4.000 EA
HW2501D13	KEY, 3/16 SQ X 1.375	1.000 EA
HA7000A01	KEY RETAINER 7/8" DIA SHAFT	1.000 EA
85XU0407S04	4X1/4 U DRIVE PIN STAINLESS	6.000 EA
NP0018F	ALUM UL XP CONDUIT BOX NAMEPLATE	1.000 EA
MJ1000A02	GREASE, POLYREX EM EXXON (USe 4824-15A)	0.050 LB
34FN3002B01	EXTERNAL FAN, PLASTIC, .637/.639 HUB W/	1.000 EA
51XB1214A16	12-14X1.00 HXWSSLD SERTYB	1.000 EA
MG1025G29	WILKOFAS, 789.229, DARK CHARCOAL GRAY	0.014 GA

Parts List (continued)		
Part Number	Description	Quantity
HA3104A10	THRUBOLT, 5/16-18 X 10.25	4.000 EA
MN416A01	TAG-INSTAL-MAINT no wire (1200/bx) 5/18	1.000 EA
LB1119N	WARNING LABEL	1.000 EA
LC0145B01	CONNECTION LABEL	1.000 EA
NP0015XPSLEV	SS XP UL CSA-EEV CC CL-I GP-D	1.000 EA
G7PA1000	PKG GRP, PRINT PK1034A06	1.000 EA

AC Induction Motor Performance Data

Record # 35668 - Typical performance - not guaranteed values

Winding: 35WGQ060-R003	Type: 3532M	Enclosure: XPFC
-------------------------------	--------------------	------------------------

Nameplate Data				460 V, 60 Hz: High Voltage Connection	
Rated Output (HP)	3			Full Load Torque	4.5 LB-FT
Volts	230/460			Start Configuration	direct on line
Full Load Amps	7.2/3.6			Breakdown Torque	18 LB-FT
R.P.M.	3450			Pull-up Torque	11 LB-FT
Hz	60	Phase	3	Locked-rotor Torque	16 LB-FT
NEMA Design Code	B	KVA Code	L	Starting Current	33 A
Service Factor (S.F.)	1			No-load Current	1.2 A
NEMA Nom. Eff.	86.5	Power Factor	92	Line-line Res. @ 25°C	4.72 Ω
Rating - Duty	40C AMB-CONT			Temp. Rise @ Rated Load	61°C
S.F. Amps				Temp. Rise @ S.F. Load	73°C
				Locked-rotor Power Factor	47
				Rotor inertia	0.0885 LB-FT ²

Load Characteristics 460 V, 60 Hz, 3 HP

% of Rated Load	25	50	75	100	125	150
Power Factor	57	77	85	88	89	90
Efficiency	84.1	87.9	88.4	87.2	85.7	83.5
Speed	3562	3531	3498	3462	3421	3375
Line amperes	1.5	2.1	2.8	3.6	4.5	5.4

Performance Graph at 460V, 60Hz, 3.0HP Typical performance - Not guaranteed values

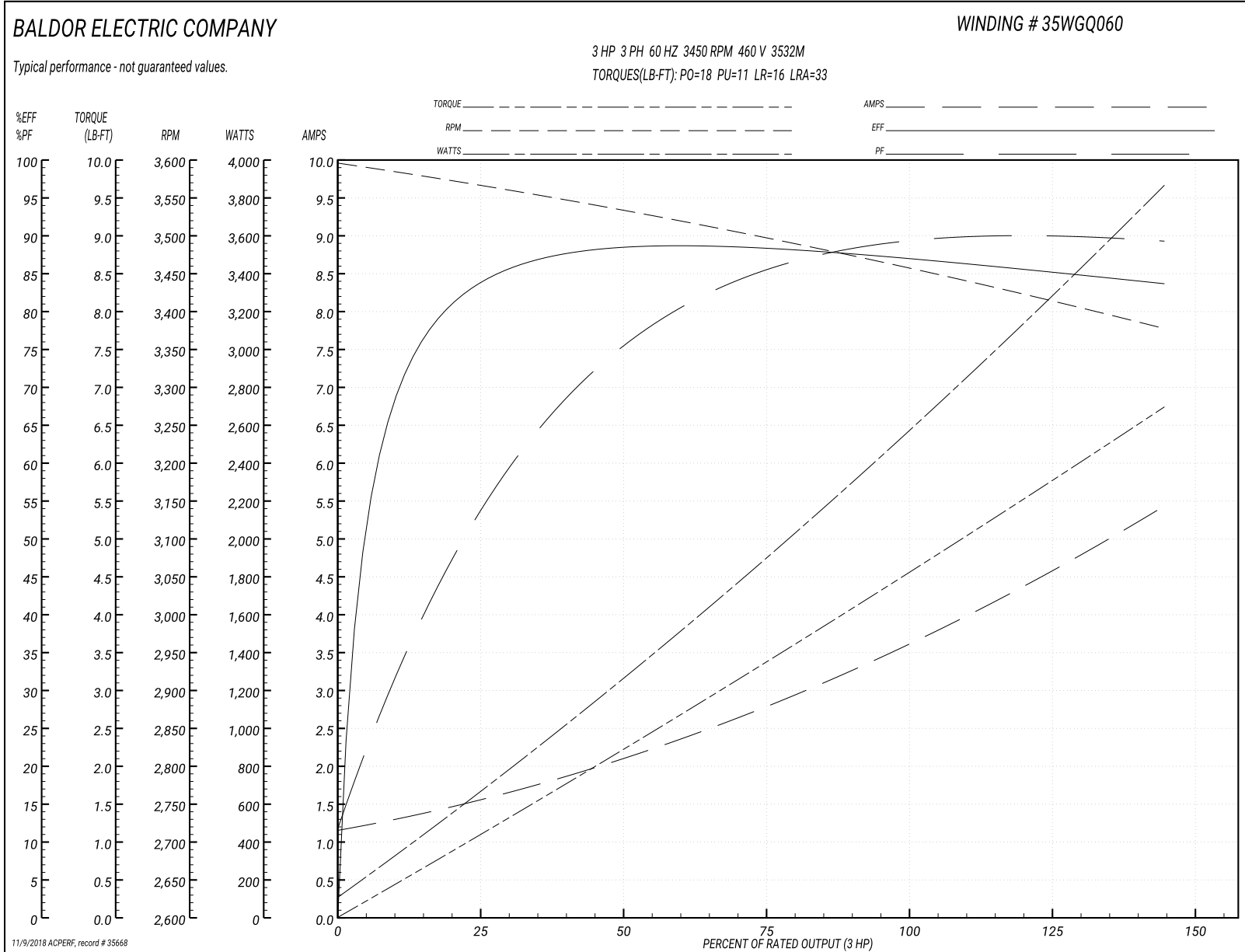

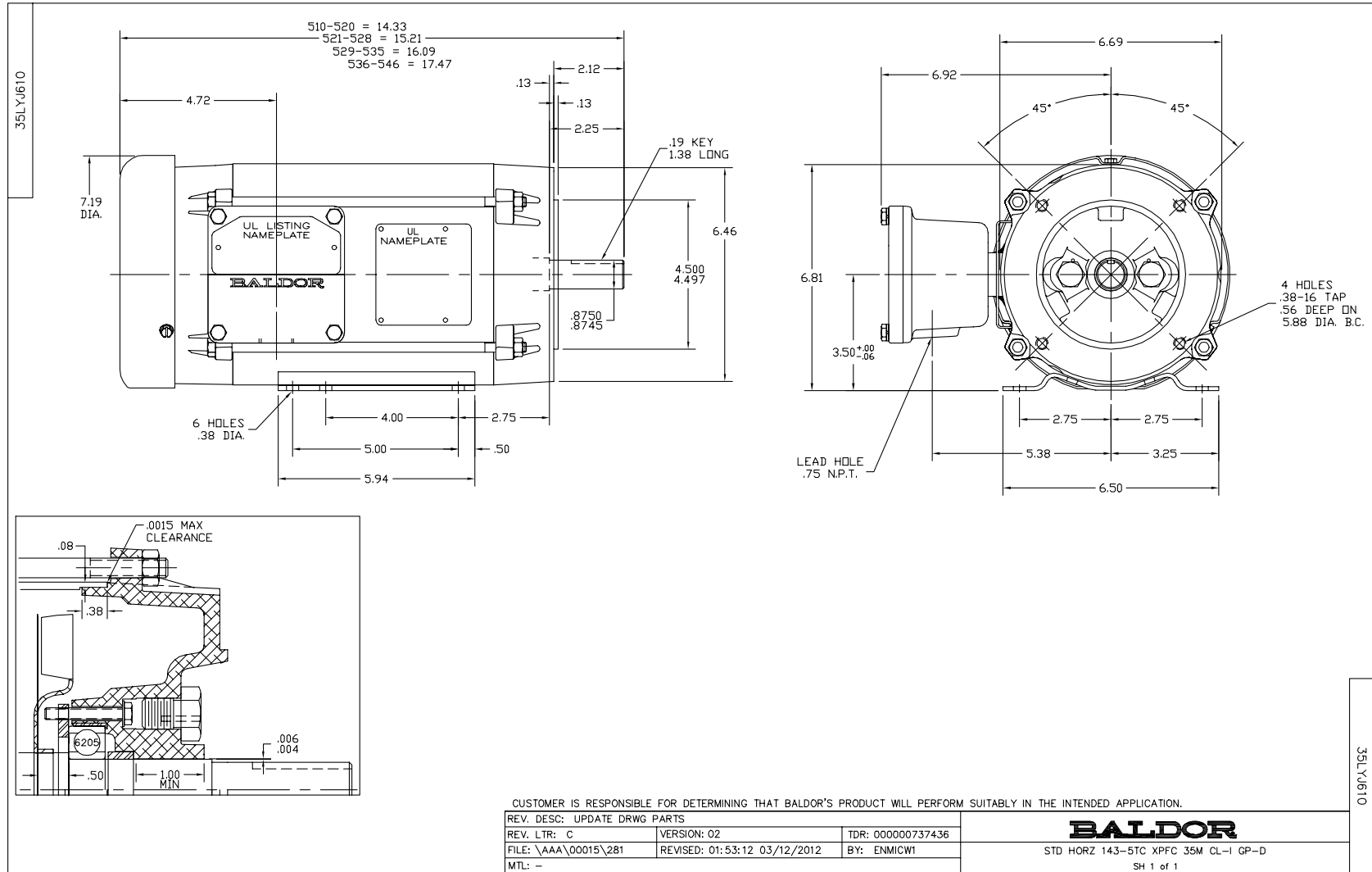

CD0005



LOW VOLTAGE
(2Y)



LINE

HIGH VOLTAGE
(1Y)

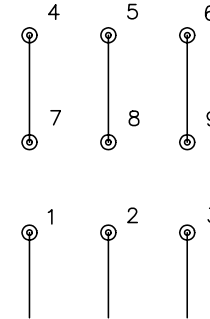

LINE

NOTES:

1. INTERCHANGE ANY TWO LINE LEADS TO REVERSE ROTATION.
2. OPTIONAL THERMOSTATS ARE PROVIDED WHEN SPECIFIED.
3. ACTUAL NUMBER OF INTERNAL PARALLEL CIRCUITS MAY BE A MULTIPLE OF THOSE SHOWN ABOVE.
4. LEAD COLORS ARE OPTIONAL. LEADS MUST ALWAYS BE NUMBERED AS SHOWN.

REV. DESC: REVISE TO SHOW OPTIONAL COLORS

REV. LTR: E BY: JLP

REVISED: 01/19/99 10:15

TDR: 0171435

900000

FILE: AAA00005140

MDL: -

MTL: -

BALDOR ELECTRIC Co.

3PH, DV, 9 LEADS

CD0005