

BALDOR® • RELIANCE 

Product Information Packet

CFSWDM3555-E

2HP,3450RPM,3PH,60HZ,56C,3532M,TEFC,F1,N

Part Detail							
Revision:	C	Status:	PRD/A	Change #:		Proprietary:	No
Type:	AC	Elec. Spec:	35WGR129	CD Diagram:	CD0005	Mfg Plant:	
Mech. Spec:	35E4741	Layout:	35LYE4741	Poles:	02	Created Date:	07-25-2017
Base:	RG	Eff. Date:	06-15-2018	Leads:	9#18 15" lead length,0#0 dbl dip & bake,0#0 phase insulaY		

Specs			
Catalog Number:	CFSWDM3555-E	Inverter Code:	Inverter Ready
Enclosure:	TEFC	KVA Code:	N
Frame:	56C	Lifting Lugs:	No Lifting Lugs
Frame Material:	Stainless Steel	Locked Bearing Indicator:	Locked Bearing
Output @ Frequency:	2.000 HP @ 60 HZ	Motor Finish:	UNPAINTED
Synchronous Speed @ Frequency:	3600 RPM @ 60 HZ	Motor Lead Quantity/Wire Size:	@ 0 AWG
Voltage @ Frequency:	460.0 V @ 60 HZ		9 @ 18 AWG
	230.0 V @ 60 HZ	Motor Lead Exit:	Ko Box
XP Class and Group:	None	Motor Lead Termination:	Flying Leads
XP Division:	Not Applicable	Motor Type:	3532M
Agency Approvals:	CSA	Mounting Arrangement:	F1
	UR	Power Factor:	85
Auxillary Box:	No Auxillary Box	Product Family:	WD All SS Encapsulated
Auxillary Box Lead Termination:	None	Pulley End Bearing Type:	Sealed Bearing
Base Indicator:	Rigid	Pulley Face Code:	C-Face
Bearing Grease Type:	Polyrex EM (-20F +300F)	Pulley Shaft Indicator:	Standard
Blower:	None	Rodent Screen:	None
Current @ Voltage:	2.500 A @ 460.0 V	RoHS Status:	ROHS COMPLIANT

	5.000 A @ 230.0 V	Shaft Extension Location:	Pulley End
	5.400 A @ 208.0 V	Shaft Ground Indicator:	No Shaft Grounding
Design Code:	B	Shaft Rotation:	Reversible
Drip Cover:	No Drip Cover	Shaft Slinger Indicator:	No Slinger
Duty Rating:	CONT	Speed Code:	Single Speed
Electrically Isolated Bearing:	Not Electrically Isolated	Motor Standards:	NEMA
Feedback Device:	NO FEEDBACK	Starting Method:	Direct on line
Front Face Code:	Standard	Thermal Device - Bearing:	None
Front Shaft Indicator:	None	Thermal Device - Winding:	None
Heater Indicator:	No Heater	Vibration Sensor Indicator:	No Vibration Sensor
Insulation Class:	H	Winding Thermal 1:	None
		Winding Thermal 2:	None

Nameplate NP1953A01										
CAT.NO.	CFSWDM3555-E									
SPEC.	35E4741R129G1									
HP	2									
VOLTS	230/460									
AMP	5/2.5									
RPM	3450									
FRAME	56C				HZ	60			PH	3
SER.F.	1.15		CODE	N	DES	B		CLASS	H	
NEMA-NOM-EFF	86.5			PF	85					
RATING	40C AMB-CONT									
CC	010A				USABLE AT 208V	5.4				
DE	6205			ODE	6205					
ENCL	TEFC		SN							
	4:1CT, 10:1VT									

Parts List		
Part Number	Description	Quantity
SA346339	SA 35E4741R129G1	1.000 EA
RA334849	RA 35E4741R129G1	1.000 EA
RM1070A81	O-RING, -043 VITON/FKM .070CS X 3.489ID	1.000 EA
11XW1032G08	10-32 X .50, TAPTITE II, HEX WSHR SLTD U	1.000 EA
HW3001B02	BRASS CUP WASHER W/GROUND SYMBOL TAB,	1.000 EA
35EP1940A05	FRONT TEFC 205 BRG (STAINLESS)	1.000 EA
RM1070A25	O-RING, VITON/FKM .070CS X 6.190ID	1.000 EA
HW4600G01	.984X1.499X.25 VITON SLICK SERIES LIP	1.000 EA
HW4600E99	25 X 42 X 6 AFX SEAL, GRAPHITE INFUSED V	1.000 EA
HW4500S33	1/8 NPT STAINLESS #304 SS PLUG	3.000 EA
HA4054	SHORT T-DRAIN FITTING, .125" N.P.T.	1.000 EA
HW5100A05	WVY WSHR F/205 & 304 BRGS	1.000 EA
35EP1935A02	PULLEY 56C/143-5TC ENCL 205 BRG	1.000 EA
RM1070A25	O-RING, VITON/FKM .070CS X 6.190ID	1.000 EA
HW4600G01	.984X1.499X.25 VITON SLICK SERIES LIP	1.000 EA
HW4600E99	25 X 42 X 6 AFX SEAL, GRAPHITE INFUSED V	1.000 EA
HW4500S33	1/8 NPT STAINLESS #304 SS PLUG	3.000 EA
HA4054	SHORT T-DRAIN FITTING, .125" N.P.T.	1.000 EA
RM1070A26	O-RING,4.5MM I.D.X1.5MM C.S. (VITON)	4.000 EA
35FH4005A39	IEC FH NO GREASER DEBURR/CLEAN - SS	1.000 EA
10XN1032FS06	HEX HD CAP SCREW 10-32 X 3/8 SS FOOD SAF	3.000 EA
RM1070A81	O-RING, -043 VITON/FKM .070CS X 3.489ID	1.000 EA
HW2502D13	SS KEY, 3/16 SQ X 1.375	1.000 EA
HA7000A04	KEY RETAINER 0.625 DIA SHAFTS	1.000 EA

Parts List (continued)		
Part Number	Description	Quantity
MJ5001A27	32220KN GRAY SEALER *MIN BUY 4 QTS=1GAL	0.005 QT
MJ5004A93	FOOD GRADE (H1 RATED) ANTISEIZE THRD COM	0.005 EA
MJ1000A02	GREASE, POLYREX EM EXXON (USe 4824-15A)	0.050 LB
34FN3002B01	EXTERNAL FAN, PLASTIC, .637/.639 HUB W/	1.000 EA
19XB0818S12	8-18X3/4 HXWS TYB HIGH-LOW	1.000 EA
WD5603A01	KIT, CLOSED-END LEAD SPLICE (18-14GA)	1.000 EA
HA3100FS60	THRUBOLT, 10-32 X 10.375 SS FOOD SAFE	4.000 EA
36PA1000	PKG GRP, PRINT PK1016A06	1.000 EA
MN416A01	TAG-INSTAL-MAINT no wire (1200/bx) 5/18	1.000 EA
HA5027A07	85XU1208S08 FACE DRAIN PINS BAGGED	1.000 EA
FE-0000002	ZRTG FE ASSEMBLY	1.000 EA
PE-0000002	ZRTG PE ASSEMBLY	1.000 EA

AC Induction Motor Performance Data

Record # 57369 - Typical performance - not guaranteed values

Winding: 35WGR129-R013	Type: 3532M	Enclosure: TEFC
-------------------------------	--------------------	------------------------

Nameplate Data				460 V, 60 Hz: High Voltage Connection	
Rated Output (HP)	2			Full Load Torque	2.99 LB-FT
Volts	230/460			Start Configuration	direct on line
Full Load Amps	5/2.5			Breakdown Torque	15.9 LB-FT
R.P.M.	3450			Pull-up Torque	9.04 LB-FT
Hz	60	Phase	3	Locked-rotor Torque	13.8 LB-FT
NEMA Design Code	B	KVA Code	N	Starting Current	31 A
Service Factor (S.F.)	1.15			No-load Current	1.13 A
NEMA Nom. Eff.	86.5	Power Factor	85	Line-line Res. @ 25°C	5.59 Ω
Rating - Duty	40C AMB-CONT			Temp. Rise @ Rated Load	51°C
S.F. Amps				Temp. Rise @ S.F. Load	59°C
				Locked-rotor Power Factor	47.5
				Rotor inertia	0.0885 LB-FT ²

Load Characteristics 460 V, 60 Hz, 2 HP

% of Rated Load	25	50	75	100	125	150	S.F.
Power Factor	48	70	80	86	89	91	88
Efficiency	75.8	84.9	86.5	87.1	86.6	85.7	86.8
Speed	3574	3549	3525	3500	3471	3441	3483
Line amperes	1.27	1.62	2.03	2.5	3.04	3.6	2.82

Performance Graph at 460V, 60Hz, 2.0HP Typical performance - Not guaranteed values

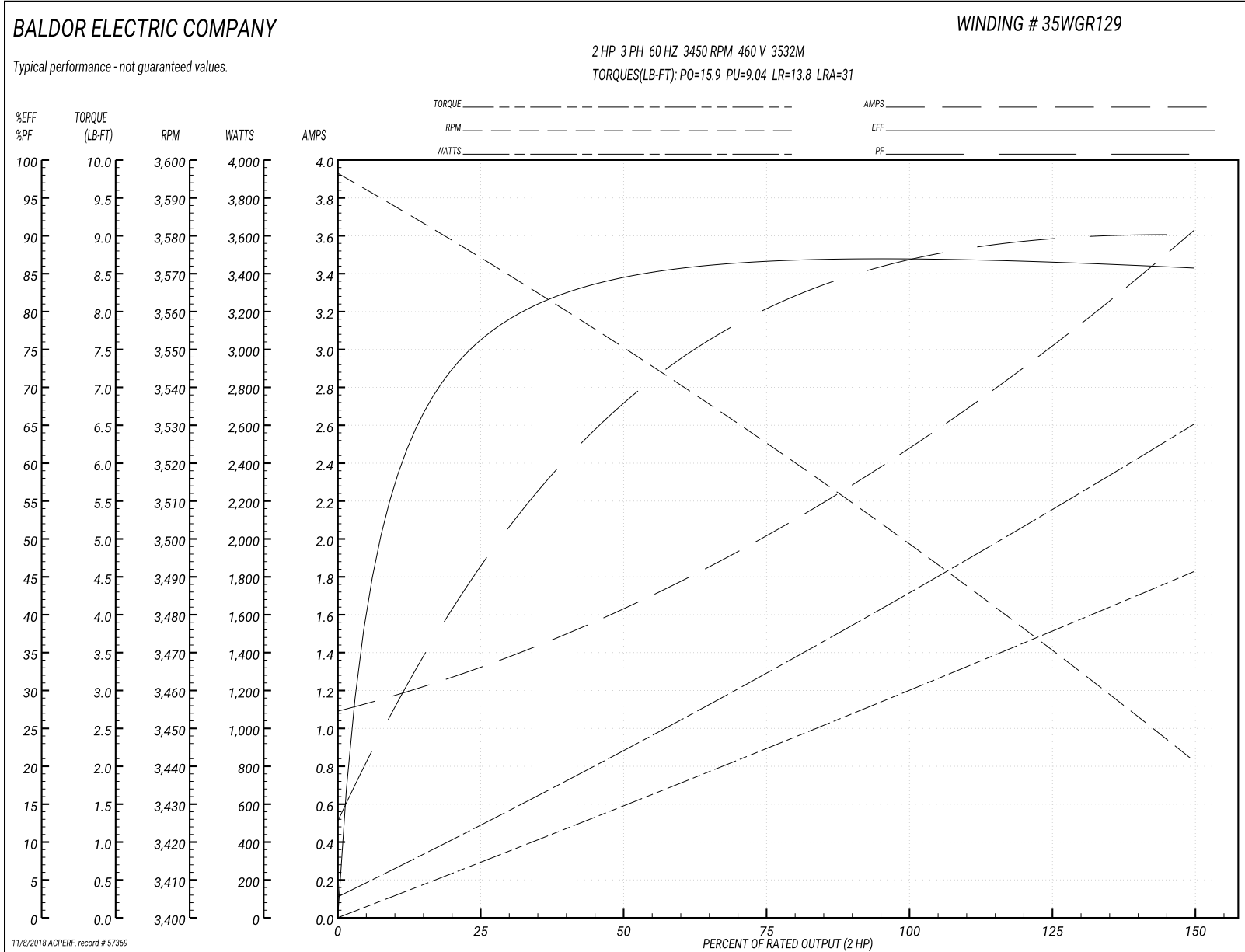

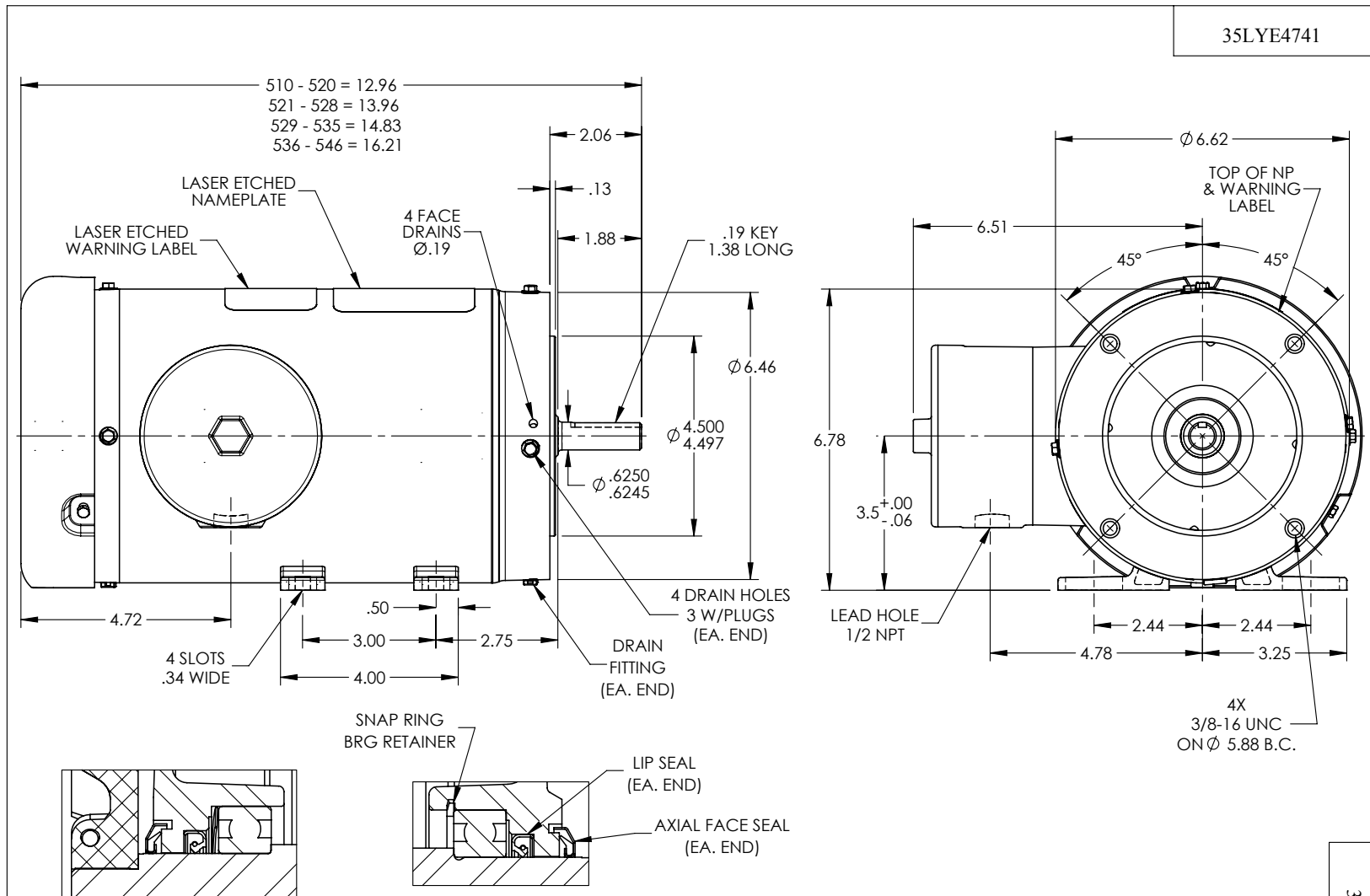

FRONT END DETAIL

PULLEY END DETAIL

CUSTOMER IS RESPONSIBLE FOR DETERMINING THAT BALDOR'S PRODUCT WILL PERFORM SUITABLY IN THE INTENDED APPLICATION

REV. DESC: NP LEADER POINTED TO WARNING LABEL & LEADER FOR			
REV: A	VERSION: 01	REVISED: 01:39:56 01/15/2018	TDR: 000001056998
35LYE4741		MODEL NO. 35LYE4741	REF: -
		BY: ENMARH0	

BALDOR

STD HORZ 56C TEFC 35M WD11/12

35LYE4741

CD0005



LOW VOLTAGE
(2Y)



LINE

HIGH VOLTAGE
(1Y)

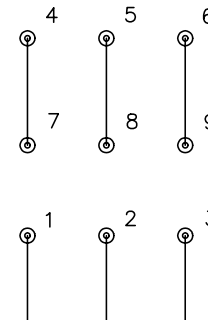

LINE

NOTES:

1. INTERCHANGE ANY TWO LINE LEADS TO REVERSE ROTATION.
2. OPTIONAL THERMOSTATS ARE PROVIDED WHEN SPECIFIED.
3. ACTUAL NUMBER OF INTERNAL PARALLEL CIRCUITS MAY BE A MULTIPLE OF THOSE SHOWN ABOVE.
4. LEAD COLORS ARE OPTIONAL. LEADS MUST ALWAYS BE NUMBERED AS SHOWN.

REV. DESC: REVISE TO SHOW OPTIONAL COLORS

REV. LTR: E BY: JLP

REVISED: 01/19/99 10:15

TDR: 0171435

90000

FILE: AAA00005140

MDL: -

MTL: -

BALDOR ELECTRIC Co.

3PH, DV, 9 LEADS

CD0005