

**BALDOR® • RELIANCE** 

**Product Information Packet**

**CFSWDM3558T-E**

**2HP,1750RPM,3PH,60HZ,145TC,3528M,TEFC,F1**

Part Detail							
Revision:	B	Status:	PRD/A	Change #:		Proprietary:	No
Type:	AC	Elec. Spec:	35WGL773	CD Diagram:	CD0005	Mfg Plant:	
Mech. Spec:	35E4743	Layout:	35LYE4743	Poles:	04	Created Date:	07-31-2017
Base:	RG	Eff. Date:	04-11-2018	Leads:	9#18		

Specs			
Catalog Number:	CFSWDM3558T-E	Inverter Code:	Inverter Ready
Enclosure:	TEFC	KVA Code:	L
Frame:	145TC	Lifting Lugs:	No Lifting Lugs
Frame Material:	Stainless Steel	Locked Bearing Indicator:	Locked Bearing
Output @ Frequency:	2.000 HP @ 60 HZ	Motor Finish:	UNPAINTED
Synchronous Speed @ Frequency:	1800 RPM @ 60 HZ	Motor Lead Quantity/Wire Size:	9 @ 18 AWG
Voltage @ Frequency:	460.0 V @ 60 HZ	Motor Lead Exit:	Ko Box
	230.0 V @ 60 HZ	Motor Lead Termination:	Flying Leads
XP Class and Group:	None	Motor Type:	3528M
XP Division:	Not Applicable	Mounting Arrangement:	F1
Agency Approvals:	CSA	Power Factor:	75
	UR	Product Family:	WD All SS Encapsulated
Auxillary Box:	No Auxillary Box	Pulley End Bearing Type:	Sealed Bearing
Auxillary Box Lead Termination:	None	Pulley Face Code:	C-Face
Base Indicator:	Rigid	Pulley Shaft Indicator:	Standard
Bearing Grease Type:	Polyrex EM (-20F +300F)	Rodent Screen:	None
Blower:	None	RoHS Status:	ROHS COMPLIANT
Current @ Voltage:	2.800 A @ 460.0 V	Shaft Extension Location:	Pulley End

	5.600 A @ 230.0 V	<b>Shaft Ground Indicator:</b>	No Shaft Grounding
	5.800 A @ 208.0 V	<b>Shaft Rotation:</b>	Reversible
<b>Design Code:</b>	B	<b>Shaft Slinger Indicator:</b>	No Slinger
<b>Drip Cover:</b>	No Drip Cover	<b>Speed Code:</b>	Single Speed
<b>Duty Rating:</b>	CONT	<b>Motor Standards:</b>	NEMA
<b>Electrically Isolated Bearing:</b>	Not Electrically Isolated	<b>Starting Method:</b>	Direct on line
<b>Feedback Device:</b>	NO FEEDBACK	<b>Thermal Device - Bearing:</b>	None
<b>Front Face Code:</b>	Standard	<b>Thermal Device - Winding:</b>	None
<b>Front Shaft Indicator:</b>	None	<b>Vibration Sensor Indicator:</b>	No Vibration Sensor
<b>Heater Indicator:</b>	No Heater	<b>Winding Thermal 1:</b>	None
<b>Insulation Class:</b>	H	<b>Winding Thermal 2:</b>	None

<b>Nameplate NP1953A01</b>										
<b>CAT.NO.</b>	CFSWDM3558T-E									
<b>SPEC.</b>	35E4743L773G2									
<b>HP</b>	2									
<b>VOLTS</b>	230/460									
<b>AMP</b>	5.6/2.8									
<b>RPM</b>	1750									
<b>FRAME</b>	145TC				<b>HZ</b>	60			<b>PH</b>	3
<b>SER.F.</b>	1.15		<b>CODE</b>	L	<b>DES</b>	B		<b>CLASS</b>	H	
<b>NEMA-NOM-EFF</b>	86.5			<b>PF</b>	75					
<b>RATING</b>	40C AMB-CONT									
<b>CC</b>	010A				<b>USABLE AT 208V</b>			5.8		
<b>DE</b>	6205			<b>ODE</b>	6205					
<b>ENCL</b>	TEFC		<b>SN</b>							
	4:1CT, 10:1VT									

Parts List		
Part Number	Description	Quantity
SA350713	SA 35E4743L773G2	1.000 EA
RA339377	RA 35E4743L773G2	1.000 EA
35FN3002A05SP	EXFN, PLASTIC, 6.376 OD, .638 ID	1.000 EA
11XW1032G08	10-32 X .50, TAPTITE II, HEX WSHR SLTD U	1.000 EA
HW3001B02	BRASS CUP WASHER W/GROUND SYMBOL TAB,	1.000 EA
35EP1940A05	FRONT TEFC 205 BRG (STAINLESS)	1.000 EA
RM1070A25	O-RING, VITON/FKM .070CS X 6.190ID	1.000 EA
HW4600G01	.984X1.499X.25 VITON SLICK SERIES LIP	1.000 EA
HW4600E99	25 X 42 X 6 AFX SEAL, GRAPHITE INFUSED V	1.000 EA
HW4600E99	25 X 42 X 6 AFX SEAL, GRAPHITE INFUSED V	1.000 EA
HW4500S33	1/8 NPT STAINLESS #304 SS PLUG	3.000 EA
HA4054	SHORT T-DRAIN FITTING, .125" N.P.T.	1.000 EA
HW5100A05	WVY WSHR F/205 & 304 BRGS	1.000 EA
35EP1935A02	PULLEY 56C/143-5TC ENCL 205 BRG	1.000 EA
RM1070A25	O-RING, VITON/FKM .070CS X 6.190ID	1.000 EA
HW4600G01	.984X1.499X.25 VITON SLICK SERIES LIP	1.000 EA
HW4500S33	1/8 NPT STAINLESS #304 SS PLUG	3.000 EA
HA4054	SHORT T-DRAIN FITTING, .125" N.P.T.	1.000 EA
RM1070A26	O-RING,4.5MM I.D.X1.5MM C.S. (VITON)	4.000 EA
35FH4005A39	IEC FH NO GREASER DEBURR/CLEAN - SS	1.000 EA
10XN1032FS06	HEX HD CAP SCREW 10-32 X 3/8 SS FOOD SAF	3.000 EA
RM1070A81	O-RING, -043 VITON/FKM .070CS X 3.489ID	1.000 EA
RM1070A81	O-RING, -043 VITON/FKM .070CS X 3.489ID	1.000 EA
HW2502D13	SS KEY, 3/16 SQ X 1.375	1.000 EA

<b>Parts List (continued)</b>		
<b>Part Number</b>	<b>Description</b>	<b>Quantity</b>
HA7000A01	KEY RETAINER 7/8" DIA SHAFT	1.000 EA
MJ5001A27	32220KN GRAY SEALER *MIN BUY 4 QTS=1GAL	0.005 QT
MJ5004A93	FOOD GRADE (H1 RATED) ANTISEIZE THRD COM	0.005 EA
MJ1000A02	GREASE, POLYREX EM EXXON (USe 4824-15A)	0.050 LB
11XB1214S16	12-14X1.00 HXWSSLD TYP B STAINLESS	1.000 EA
WD5603A01	KIT, CLOSED-END LEAD SPLICE (18-14GA)	1.000 EA
HA3100FS25	THRUBOLT, 10-32 X 9.500 SS FOOD SAFE	4.000 EA
36PA1001	PKG GRP, PRINT PK1017A06	1.000 EA
MN416A01	TAG-INSTAL-MAINT no wire (1200/bx) 5/18	1.000 EA
HA5027A07	85XU1208S08 FACE DRAIN PINS BAGGED	1.000 EA
FE-0000002	ZRTG FE ASSEMBLY	1.000 EA
PE-0000002	ZRTG PE ASSEMBLY	1.000 EA

**AC Induction Motor Performance Data**

Record # 65619 - Typical performance - not guaranteed values

<b>Winding:</b> 35WGL773-R001	<b>Type:</b> 3528M	<b>Enclosure:</b> TEFC
-------------------------------	--------------------	------------------------

Nameplate Data				460 V, 60 Hz: High Voltage Connection	
Rated Output (HP)	2			Full Load Torque	6.01 LB-FT
Volts	230/460			Start Configuration	direct on line
Full Load Amps	5.6/2.8			Breakdown Torque	23.98 LB-FT
R.P.M.	1750			Pull-up Torque	11.82 LB-FT
Hz	60	Phase	3	Locked-rotor Torque	17.34 LB-FT
NEMA Design Code	B	KVA Code	L	Starting Current	23.03 A
Service Factor (S.F.)	1.15			No-load Current	1.64 A
NEMA Nom. Eff.	86.5	Power Factor	75	Line-line Res. @ 25°C	7.75 Ω
Rating - Duty	40C AMB-CONT			Temp. Rise @ Rated Load	74°C
S.F. Amps				Temp. Rise @ S.F. Load	89°C
				Locked-rotor Power Factor	49.2
				Rotor inertia	0.165 LB-FT <sup>2</sup>

Load Characteristics 460 V, 60 Hz, 2 HP

% of Rated Load	25	50	75	100	125	150	S.F.
Power Factor	34	54	69	77	81	84	79
Efficiency	78.3	85.7	87	86.6	85.8	84.1	86.1
Speed	1789	1778	1764	1750	1736	1719	1742
Line amperes	1.73	1.97	2.33	2.83	3.35	3.98	3.14

Performance Graph at 460V, 60Hz, 2.0HP Typical performance - Not guaranteed values

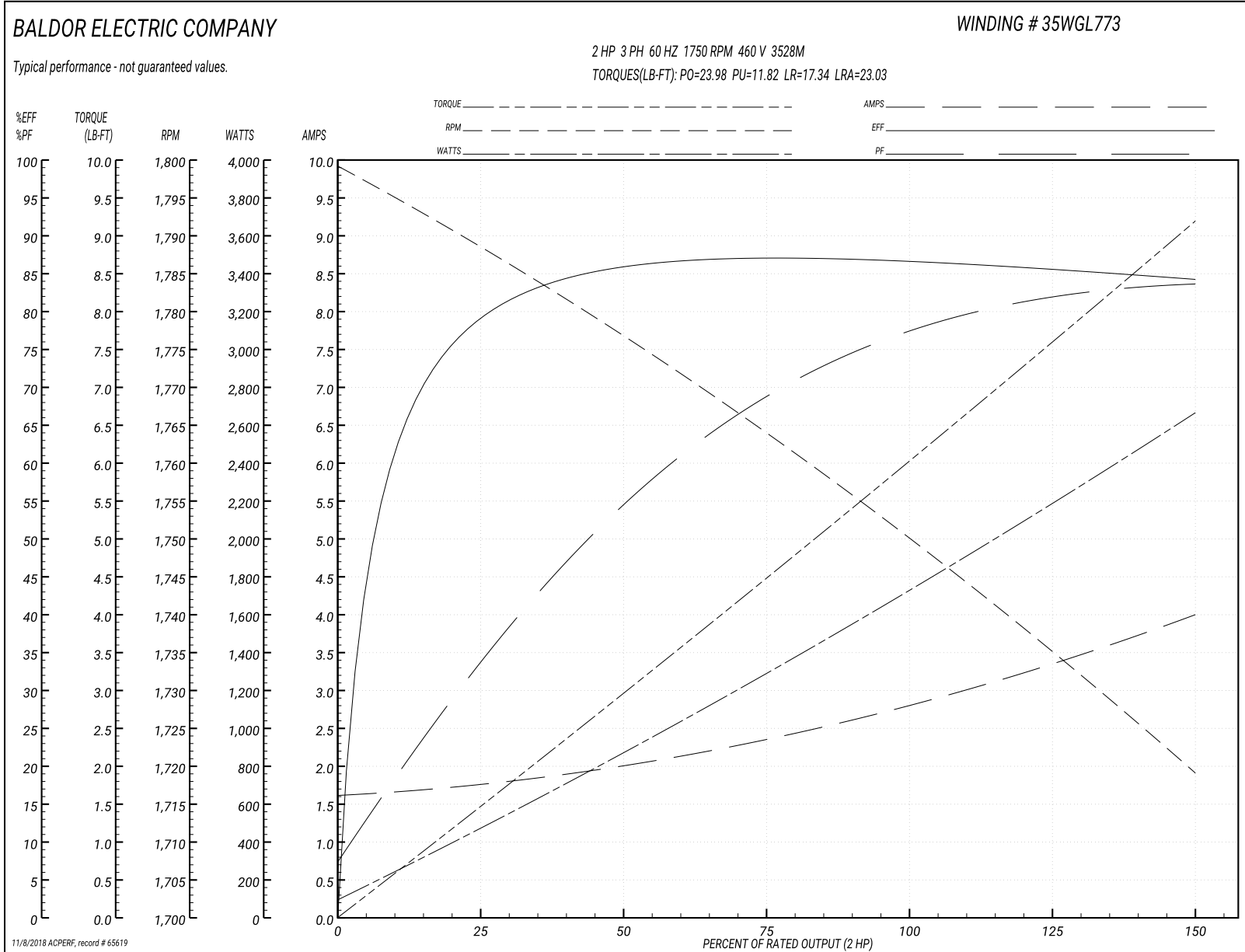



35LYE4743

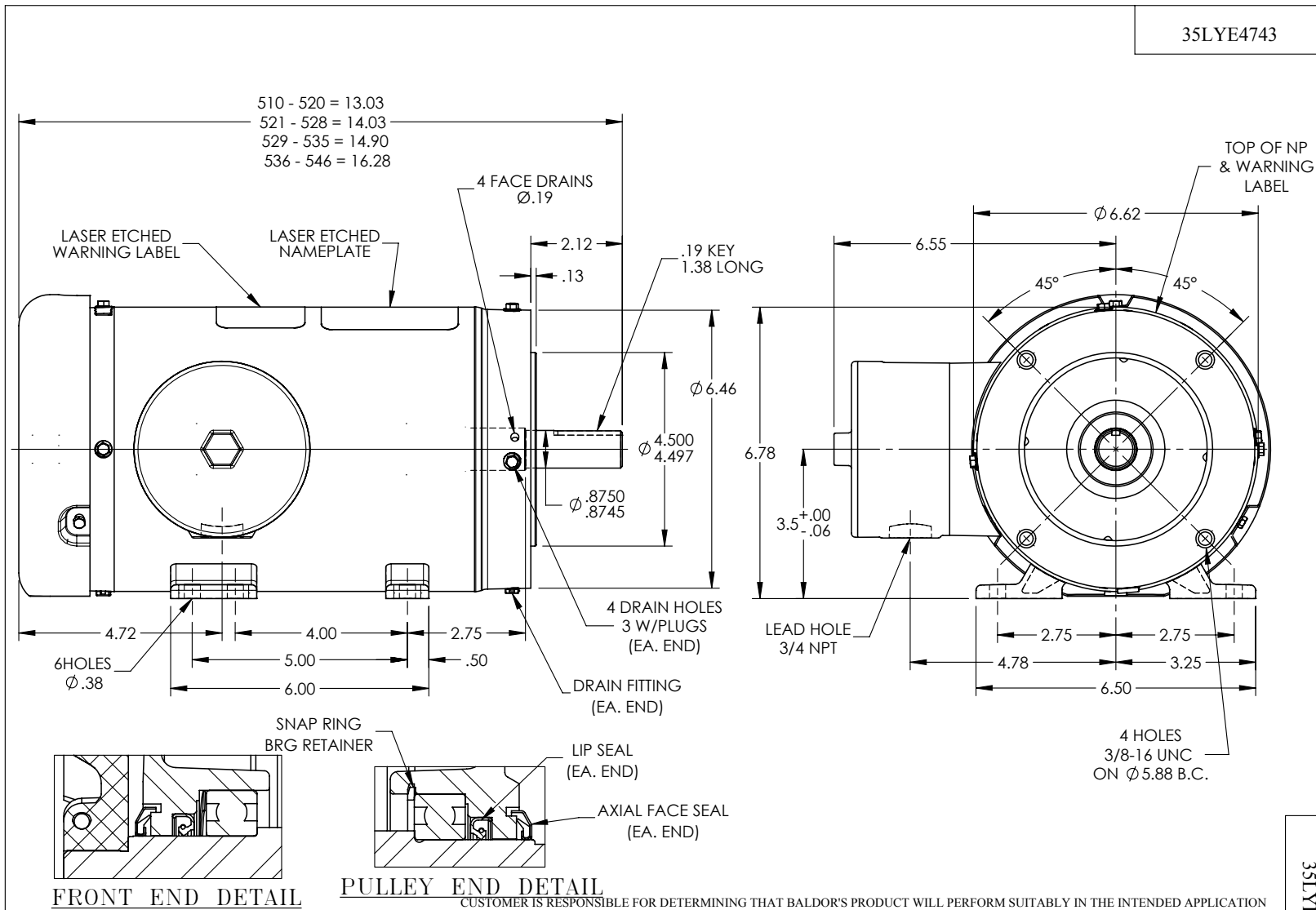

35LYE4743

REV. DESC: NEW			
REV: -	VERSION: 00	REVISED: 03:05:52 01/15/2018	TDR: 000001030651
35LYE4743		MODEL NO. 35LYE4743	REF: -
		BY: ENMARH0	

**BALDOR**

STD HORZ 143-5TC TEFC 35M WD11/12

CD0005



LOW VOLTAGE  
(2Y)



LINE

HIGH VOLTAGE  
(1Y)

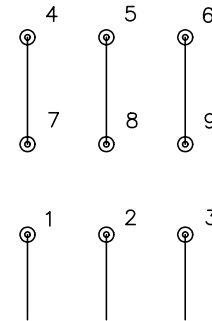

LINE

NOTES:

1. INTERCHANGE ANY TWO LINE LEADS TO REVERSE ROTATION.
2. OPTIONAL THERMOSTATS ARE PROVIDED WHEN SPECIFIED.
3. ACTUAL NUMBER OF INTERNAL PARALLEL CIRCUITS MAY BE A MULTIPLE OF THOSE SHOWN ABOVE.
4. LEAD COLORS ARE OPTIONAL. LEADS MUST ALWAYS BE NUMBERED AS SHOWN.

REV. DESC: REVISE TO SHOW OPTIONAL COLORS			
REV. LTR: E	BY: JLP	REVISED: 01/19/99 10:15	TDR: 0171435
900000		FILE: AAA00005140	MDL: -
		MTL: -	

**BALDOR ELECTRIC Co.**

3PH, DV, 9 LEADS

CD0005