

BALDOR® • RELIANCE 

Product Information Packet

D2015R

15 1750 SC2113ATZ DPG 240V

Part Detail							
Revision:	-	Status:	PRD/A	Change #:		Proprietary:	No
Type:	DC	Prod. Type:		Elec. Spec:	G6067A A	CD Diagram:	406770-001
Enclosure:	DP	Mfg Plant:		Mech. Spec:		Layout:	609950-001
Frame:	SC211	Mounting:	F1	Poles:	00	Created Date:	04-09-2015
Base:		Rotation:	R	Insulation:	F	Eff. Date:	04-13-2015
Field Type:		Literature:		Elec. Diagram:		Replaced By:	

Specs			
Enclosure:	DP		
Frame:	SC2113ATZ		
Frame Material:	Steel		
Agency Approvals:	CCSA US		
Base Indicator:	Rigid		
Bearing Grease Type:	Polyrex EM (-20F +300F)		
Drip Cover:	No Drip Cover		
Duty Rating:	CONT		
Feedback Device:	NO FEEDBACK		
Field Winding Type:	STAB SHUNT		
Frame Prefix:	SC		
Heater Indicator:	No Heater		
Insulation Class:	F		
Lifting Lugs:	Standard Lifting Lugs		
Mounting Arrangement:	F1		
Shaft Extension Location:	Pulley End		

Shaft Ground Indicator:	No Shaft Grounding		
Shaft Slinger Indicator:	No Slinger		
Motor Standards:	NEMA		

Nameplate 000613006HP			
CAT.NO.	D2015R	SPEC NO.	T21S1330
FR	SC 2113ATZ	HP	15
ENCL.	DP	DUTY	CONT
ENCL MOD	GUARDED	RPM	1750/ 2300
MAX SAFE SPEED	4500	VOLTS	240
		S.F.	1.0
		INSUL	F
		AMPS	56.00
		AMB.	40
		SER.NO.	
	FIELD DATA	POWER CODE	C
WINDING	STAB SHUNT	D.E. BRG.	50BC03J30X
VOLTS	150	O.D.E. BRG.	45BC02J30X
MAX AMPS @ 25 C	4.12	MIN. AMB.	0
HOT AMPS	2.85/ 1.92	TYPE	TR
	BRUSH:419904051AD		

Parts List		
Part Number	Description	Quantity
SA297157	SA T21S1330	1.000 EA
AA016175	AA T21S1330	1.000 EA
000613006HP	NAMEPLATE - RPM III D-C MOTOR W/CSA LOGO	1.000 EA
000692000FP	NP, WARNING LIFT INSTRUCTIONS	1.000 EA
000692000FS	WARNING LABEL	1.000 EA
036170004EA	ROUND HEAD DRIVE SCREW	6.000 EA
406770001	C/D TAG (STAB SHUNT)	1.000 EA
034182010GA	KEY 1/2 X 3/8 X 1.25"	1.000 EA
036000012HB	HHCS M6X12MM LONG PLATED	4.000 EA
036000020KB	MHHCS M10-1.5X20MM PLTD.	4.000 EA
036501008AB	KPNUT M6-1.0 ZINCPLTED	8.000 EA
036610010AB	MHSLW M10 PLATED	4.000 EA
419904-51AD	BRUSH C	4.000 EA
419905003A	FLAT WASHER ROCKER RPM III RGG	4.000 EA
419905008A	HARDWARE	8.000 EA
706364051RBA	BRHLD METRIC SPRING CHG.	4.000 EA
706372001B	ROCKR METRIC	1.000 EA
034693001AB	PPLG - G508- use 034692001AB	1.000 EA
034693001AB	PPLG - G508- use 034692001AB	1.000 EA
035000001A	ALFTG 1/8" 1610-BL	1.000 EA
035000001BB	GREASE FTG,GRS.IN	1.000 EA
036000055JB	HHCS,DE CAP	2.000 EA
036000060KB	HHCS,DE CAP	3.000 EA
036500010AB	METRIC NUT M10-1.5PLTD400	4.000 EA

Parts List (continued)		
Part Number	Description	Quantity
036500010AB	METRIC NUT M10-1.5PLTD400	4.000 EA
048977006B	GRFTG - XP	1.000 EA
400638001H	SPRING WASHER	1.000 EA
418150003A	GREASE FITTING CAP	2.000 EA
609830005M	TBOLT METRIC RP609830-	4.000 EA
801924102A	BRKT,ODE,C210	1.000 EA
801925102A	BRKT,DE,C210	1.000 EA
032018004CK	HHCS 3/8-16X1/2L PLATED	4.000 EA
036000012HB	HHCS M6X12MM LONG PLATED	2.000 EA
036000045JB	M8-1.25 X 45MM HXHCS	4.000 EA
036620009AB	M8 EXTERNAL LK WASHER	1.000 EA
065564000B	GASK 250-280	1.000 EA
075453000A	CBOXC, PAINTED 250-280	1.000 EA
417733001D	GASKT	2.000 EA
418010006A	CAST,MPLATE,180-280,EX1,7BY	1.000 EA
418018074A	GROUND LABEL G100 METRIC 160 D.C.	1.000 EA
422919001	CVRKT BE SOLID C210	1.000 EA
422919003	HHCVR KIT,C210,DE,LOUVERED	1.000 EA
422919003	HHCVR KIT,C210,DE,LOUVERED	1.000 EA
422919012	HHCVR KIT,C210,ODE,SOLID	1.000 EA
422919014	HHCVR KIT,C210,ODE,LOUVERED	1.000 EA
422919014	HHCVR KIT,C210,ODE,LOUVERED	1.000 EA
706305026A	GUARD,SHAFT	1.000 EA
706320005A	CONDUIT BOX	1.000 EA

Product Information Packet: D2015R - 15 1750 SC2113ATZ DPG 240V

000640000P	TAG WINDING THERMOST	1.000 EA
000692000NG	LABEL ;NP 4POLE METRIC LABEL	1.000 EA
034180020GA	KEY 1/2X1/2X2-1/2 L	1.000 EA

609950-001

INDUSTRIAL DIRECT CURRENT MOTORS AND GENERATORS - RPM III

ENCLOSURE: DRIP-PROOF FULLY-GUARDED,
SPLASHPROOF, TOTALLY ENCLOSED

COOLING: SELF-VENTILATED
NON-VENTILATED

MOUNTING: FOOT
METHOD OF DRIVE: COUPLED OR BELTED

ACCESSORIES: PROVISION FOR
TACHOMETER MOUNTING
ONLY WHEN SPECIFIED

FRAMES SC2113ATZ THRU LC2812ATZ

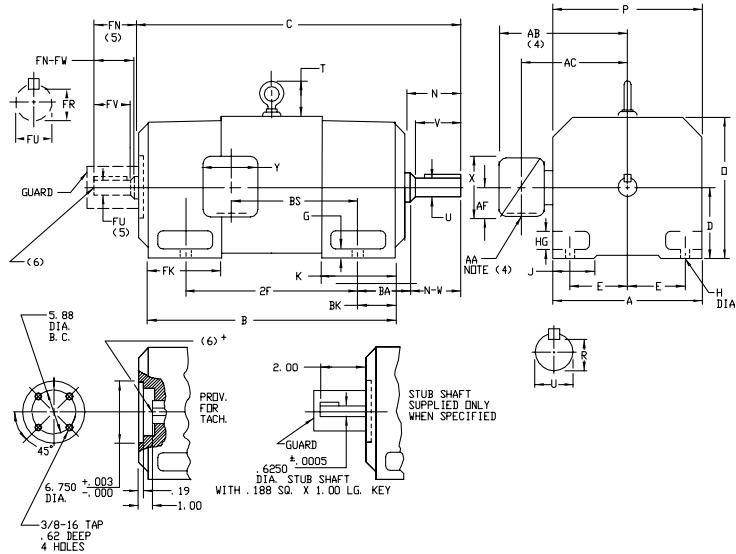

DIMENSIONS ARE IN INCHES; SEE 609950-1M FOR DIMENSIONS IN MILLIMETERS

FRAME	A	B(1)	E	G	H	HG	J	D	P	T	BA	K	FK	BK
SC2113ATZ-LC2113ATZ	10.25	5.25	4.25	.44	.44	1.38	1.75	10.44	10.31	2.56	3.50	5.19	6.81	2.38
SC2512ATZ-LC2512ATZ	12.31	6.25	5.00	.50	.56	1.62	2.00	12.50	12.44	3.06	4.25	6.06	8.00	3.00
MC2812ATZ-LC2812ATZ	13.78	7.00	5.50	.62	.56	1.88	2.75	14.00	13.94	3.38	4.75	6.75	9.19	3.50

FRAME	C(7)	B	BS	2F	DRIVE END SHAFT AND KEY							OPPOSITE DRIVE END SHAFT AND KEY(S)					WT. LBS.		
					N	N-W	UK(2)	V	RC(3)	SO.	LGTH.	FN	FN-FW	FK(2)	FV	FR(3)		SD	LGTH.
SC2113ATZ	28.38	22.50	11.38	18.00	4.00	3.75	1.875	3.50	1.591	.500	2.50	3.50	3.25	1.625	3.00	1.416	.375	2.25	315
MC2113ATZ	29.62	23.75	12.62	18.00	4.00	3.75	1.875	3.50	1.591	.500	2.50	3.50	3.25	1.625	3.00	1.416	.375	2.25	340
LC2113ATZ	31.25	25.38	14.25	18.00	4.00	3.75	1.875	3.50	1.591	.500	2.50	3.50	3.25	1.625	3.00	1.416	.375	2.25	370
SC2512ATZ	31.69	25.06	12.06	20.00	4.50	4.25	2.125	4.00	1.845	.500	3.00	4.00	3.75	1.875	3.50	1.591	.500	2.50	505
MC2512ATZ	33.19	26.56	13.56	20.00	4.50	4.25	2.125	4.00	1.845	.500	3.00	4.00	3.75	1.875	3.50	1.591	.500	2.50	540
LC2512ATZ	34.69	28.06	15.06	20.00	4.50	4.25	2.125	4.00	1.845	.500	3.00	4.00	3.75	1.875	3.50	1.591	.500	2.50	580
MC2812ATZ	37.38	29.94	14.25	22.00	5.00	4.75	2.375	4.50	2.021	.625	3.50	4.50	4.25	2.125	4.00	1.845	.500	3.00	775
LC2812ATZ	39.62	32.19	16.50	22.00	5.00	4.75	2.375	4.50	2.021	.625	3.50	4.50	4.25	2.125	4.00	1.845	.500	3.00	850

- (1) "P" DIMENSION WILL NOT BE EXCEEDED SHIMS UP TO .03 INCHES IN THICKNESS ARE USUALLY REQUIRED FOR COUPLED OR GEARED MACHINES.
- (2) "U" AND "FU" VARY---+.000 - .001
- (3) "R" AND "FR" VARY---+.000 - .015
- (4) TERMINAL BOX VARIES WITH H.P. FOR DIMENSIONS "AA", "AB", "AC", "AF", "X" AND "Y". REFER TO BOX D/S. (STD. 609959-1, "K/P" 609959-2, MILL 609959-3)
- (5) OPPOSITE DRIVE END SHAFT SUPPLIED ONLY WHEN SPECIFIED.
- (6) MOTOR SHAFT TAPPED FOR SCREW-IN STUB SHAFT.
- (7) WHEN THE MOTOR APPLICATION DOES NOT REQUIRE THE USE OF DFP, DRIVE END, ADD .25 TO "C" DIM. FOR BRACKET COVER.

TERMINAL BOX CAN BE ROTATED FOR LEAD OUTLET AT TOP, SIDES OR BOTTOM. TERMINAL BOX LOCATED ON OPPOSITE SIDE WHEN F-2, W-1, W-4, V-5, W-7, OR C-1 MOUNTING IS SPECIFIED. BOX LOCATED ON TOP WHEN SPECIFIED. MOTOR WEIGHT MAY VARY 15% FOR NON-STANDARD RATINGS AND/OR ACCESSORIES. IF MOUNTING CLEARANCE DETAILS ARE REQUIRED, CONSULT FACTORY.

CUSTOMER IS RESPONSIBLE FOR DETERMINING THAT BALDOR'S PRODUCT WILL PERFORM SUITABLY IN THE INTENDED APPLICATION.

REV. DESC: LOADED TO BUS	VERSION: 00	TDR: 000000577407
REV. LTR: -	REVISED: 10/21/19 01/26/2011	BY: RGGBC
FILE: \RGG\00015\543		
MTL: -		

BALDOR

DIMENSION DRAWING, SC2113ATZ - LC2812ATZ, DPP, TENV, FOOT MTG

SH 1 of 1

609950-001

609959-001

INDUSTRIAL DIRECT CURRENT MOTORS
AND GENERATORS - RPM III
TERMINAL BOX DIMENSIONS
STANDARD SIZE AND ONE SIZE LARGER
FRAMES C2113ATZ THRU C2815ATZ

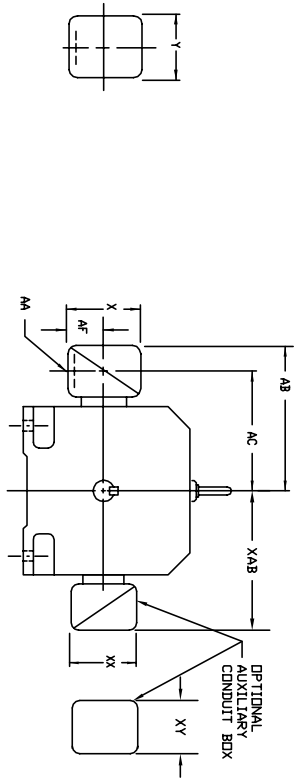

DIMENSIONS ARE IN INCHES

FRAME SIZE	STANDARD SIZE						ONE SIZE LARGER								
	MAX. AMPS	AK(1)	AB	AC	AF	PART NUMBER	AK(1)	AB	AC	AF	PART NUMBER				
C2113ATZ	40	3/4 & 1"	8.97	7.47	1.94	4.38	5.00	7.05028-1-R	1-1/4 & 1-1/2	10.03	8.03	2.50	5.50	6.12	7.05029-1-R
C2115ATZ	96	1-1/4 & 1-1/2	10.03	8.03	2.50	5.50	6.12	7.05029-1-R	2" & 2-1/2	11.16	8.41	3.19	7.00	7.62	7.05030-1-R
(2)	208	2" & 2-1/2	11.16	8.41	3.19	7.00	7.62	7.05030-1-R	2" & 2-1/2	11.16	8.41	3.19	7.00	7.62	7.05030-1-R
C2513ATZ	40	3/4 & 1"	10.03	8.53	1.94	4.38	5.00	7.05029-1-R	1-1/4 & 1-1/2	11.09	9.09	2.50	5.50	6.12	7.05029-1-R
C2515ATZ	96	1-1/4 & 1-1/2	11.09	9.09	2.50	5.50	6.12	7.05029-1-R	2" & 2-1/2	12.22	9.47	3.19	7.00	7.62	7.05030-1-R
(2)	208	2" & 2-1/2	12.22	9.47	3.19	7.00	7.62	7.05030-1-R	2" & 2-1/2	12.22	9.47	3.19	7.00	7.62	7.05030-1-R
C2813ATZ	128	2"	14.03	10.53	4.25	8.44	7.25	7.4874-4-R	3"	14.47	11.22	4.25	8.44	7.25	7.4874-4-R
C2815ATZ	185	3"	14.47	11.22	4.25	8.44	7.25	7.4874-4-R	4"	15.91	11.84	5.38	10.56	9.00	7.0308-3-R
(2)	259	4"	15.91	11.84	5.38	10.56	9.00	7.0308-3-R	5" (4)	18.72	13.47	7.00	12.75	15.00	7.02658-1-C

FRAME SIZE	STANDARD SIZE						ONE SIZE LARGER								
	MAX. AMPS	AK(3)	AB	AC	AF	PART NUMBER	AK(3)	AB	AC	AF	PART NUMBER				
C2113ATZ	18	3/4	10.03	8.03	2.50	5.00	5.75	7.05028-2-S	1"	10.03	8.03	2.50	5.00	5.75	7.05028-2-T
C2115ATZ	40	1"	10.03	8.03	2.50	5.00	5.75	7.05028-2-R	1-1/2	10.97	8.53	3.00	6.00	7.00	7.05029-2-S
(2)	96	1-1/2	10.97	8.53	3.00	6.00	7.00	7.05029-2-R	2-1/2	12.66	8.91	3.62	7.88	9.23	7.05029-2-S
208	3/4	10.97	8.53	3.00	6.00	7.00	7.05029-2-S	1"	11.09	9.09	2.50	5.00	5.75	7.05028-2-T	
C2513ATZ	40	1"	11.09	9.09	2.50	5.00	5.75	7.05028-2-T	1-1/2	12.03	9.59	3.00	6.00	7.00	7.05029-2-R
C2515ATZ	96	1-1/2	12.03	9.59	3.00	6.00	7.00	7.05029-2-S	2-1/2	12.03	9.59	3.00	6.00	7.00	7.05029-2-S
(2)	208	2"	12.03	9.59	3.00	6.00	7.00	7.05029-2-S	1-1/2	12.03	9.59	3.00	6.00	7.00	7.05029-2-S
C2813ATZ	128	2"	12.78	10.34	3.00	6.00	7.00	7.5460-1	3"	14.47	10.72	3.62	7.88	9.23	7.6700-1-R
C2815ATZ	185	3"	14.47	10.72	3.62	7.88	9.23	7.6700-1-R	4"	15.78	11.59	4.12	9.50	10.50	7.6700-1-R
(2)	259	4"	15.78	11.59	4.12	9.50	10.50	7.6700-1-R	5" (4)	18.59	13.34	7.00	12.75	15.00	7.6870-1-S

FRAME SIZE	STANDARD SIZE						ONE SIZE LARGER					
	AMP'S	AB	AC	AF	X	Y	AB	AC	AF	X	Y	
C210	100	10.71	8.98	2.72	7.48	7.48	7.48	7.48	7.48	7.48	7.48	
200	11.26	9.25	3.35	8.82	8.82	8.82	8.82	8.82	8.82	8.82	8.82	
400	11.80	9.57	2.72	7.48	7.48	7.48	7.48	7.48	7.48	7.48	7.48	
800	11.85	9.84	3.35	8.82	8.82	8.82	8.82	8.82	8.82	8.82	8.82	
C290	17.48	12.75	6.20	14.39	14.39	14.39	14.39	14.39	14.39	14.39	14.39	
400	17.48	12.75	6.20	14.39	14.39	14.39	14.39	14.39	14.39	14.39	14.39	
800	17.48	12.75	6.20	14.39	14.39	14.39	14.39	14.39	14.39	14.39	14.39	
1600	18.27	13.54	6.20	14.39	14.39	14.39	14.39	14.39	14.39	14.39	14.39	

FRAME SIZE	OPTIONAL AUXILIARY CONDUIT BOX DIMENSIONS (MAXIMUM)								
	XAB	XY	XX	YY	XX	YY			
C210	7.38	4.25	4.25	6.02007-26-A	C210	10.88	8.00	8.00	7.06310-3-B
C290	8.44	4.25	4.25	6.02007-26-A	C290	11.88	8.00	8.00	7.06310-3-B
C280	9.12	4.25	4.25	6.02007-26-A	C280	12.62	8.00	8.00	7.06310-3-B

(1) *MAX. CONDUIT
(2) STEEL TERMINAL BOX FOR C2113ATZ AND C2513ATZ
(3) *MAX. PIPE TAP
(4) TERMINAL BOX 76870-9R EXTENDS BELOW MOTOR FEET.
TERMINAL BOX CAN BE ROTATED FOR LEAD DULLET AT TOP, SIDES OR BOTTOM.
TERMINAL BOX LOCATED ON OPPOSITE SIDE WHEN F-2, V-1, V-4, V-5, V-7,
OR C-1 MOUNTING IS SPECIFIED. BOX LOCATED ON TOP WHEN SPECIFIED.
FOR *XY* TERMINAL BOX DIMENSIONS SEE 609959-2.
FOR *XX* TERMINAL BOX DIMENSIONS SEE 609959-3.

CUSTOMER IS RESPONSIBLE FOR DETERMINING THAT BALDOR'S PRODUCT WILL PERFORM SUITABLY IN THE INTENDED APPLICATION.

REV. DESC: ADD 706310-63G C/BOX TO C250 AND C280 FRAMES	VERSION: 01	TDR: 000000816512
REV. LTR: A		
FILE: \RGG\00021\153		REVISED: 03:09:09 09/06/2013
MTL: -		BY: RGGWT



DIMENSION SHEET
SH 1 of 1

609959-001

406770-001

406770-001

**CONNECTION DIAGRAM
D-C MOTOR - STAB. SHUNT**

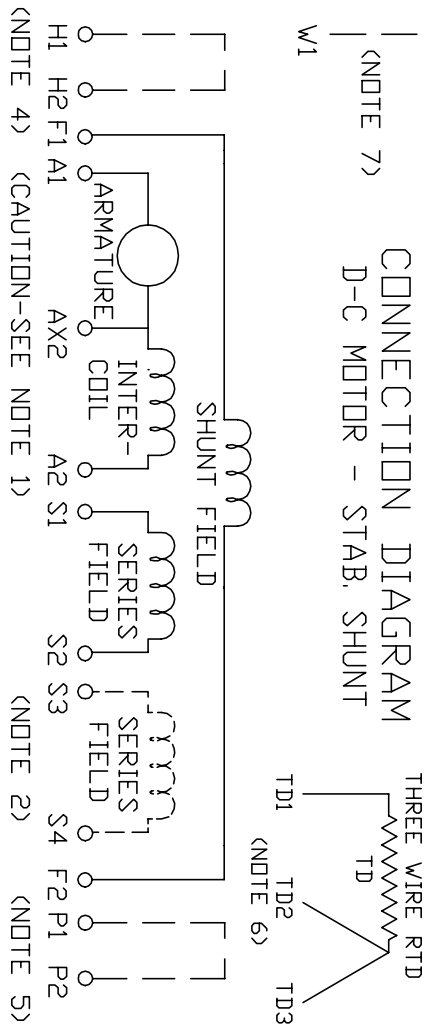

ARMATURE AND FIELD EXTERNAL CONNECTIONS
WARNING- SEE NOTE 8 FOR GROUNDING INSTRUCTIONS



ROTATION FACING COMMUTATOR END

1. **CAUTION** — ARMATURE AND SERIES FIELD MAY HAVE MULTIPLE LEADS. CONNECT ALL LUGS WITH THE SAME MARKING TOGETHER.
 2. OPTIONAL SERIES FIELD IS MARKED S3 AND S4. FOR CUMULATIVE SERIES FIELD, CONNECT S3 TO S2 AND CONNECT S4 TO NEGATIVE. FOR DIFFERENTIAL SERIES FIELD CONNECT S4 TO S2 AND S3 TO NEGATIVE.
 3. OPTIONAL CONTROL SIGNAL LEAD IS MARKED AX2. ALWAYS TAKE INTERPOLE DROP BETWEEN A2 AND AX2. NOTE: NEMA DESIGNATION FOR AX2 IS LETTER C.
 4. SPACE HEATERS, WHEN PROVIDED, WILL HAVE LEADS MARKED H1 AND H2, H3, H4, ETC.
 5. THERMAL PROTECTOR, WHEN PROVIDED, WILL HAVE LEADS MARKED P1 AND P2, P3, P4, ETC.
 6. WINDING RTD'S, WHEN PROVIDED, WILL HAVE LEADS MARKED TD1, TD2, & TD3
 7. BRUSH WEAR SENSOR, WHEN PROVIDED, WILL HAVE LEAD MARKED W1.
 8. **WARNING** — MOTOR MUST BE GROUNDED TO PREVENT SERIOUS INJURIES TO PERSONNEL. GROUND THE MOTOR PER IEC, NATIONAL ELECTRICAL CODE AND ANY APPLICABLE LOCAL ELECTRICAL CODES. A TAPPED HOLE IS PROVIDED IN THE CONDUIT BOX, ON THE FOOT. FRAME BRACE OR OPPOSITE DRIVE END BRACKET, ADJACENT TO THE TERMINAL BOX FOR MOTOR GROUNDING. GROUND LEAD, WHEN PROVIDED, WILL BE GREEN.
- CUSTOMER _____ RELIANCE
CUSTOMER ORDER NO. _____ S.D. NO. _____

REV. DESC: DELETED DUPLICATE WORDS FROM NOTE 8		
REV. LTR: A	VERSION: 01	TDR: 000000970330
FILE: \RSN\00026\422	REVISED: 10:19:12 03/11/2016	BY: RAGTBM
MTL: -		

BALDOR

D-C MOTOR CONNECTION DIAGRAM STAB. SHUNT

SH 1 of 1