

BALDOR® • RELIANCE 

Product Information Packet

D50100RS-BV

100HP, 1750RPM, DC, 3212ATZ, DPG-FV,

Part Detail							
Revision:	-	Status:	PRD/A	Change #:		Proprietary:	No
Type:	DC	Prod. Type:		Elec. Spec:	G6169B C	CD Diagram:	406770-001
Enclosure:	DP	Mfg Plant:		Mech. Spec:		Layout:	609972-049
Frame:	MC321	Mounting:	F2	Poles:	00	Created Date:	04-09-2015
Base:		Rotation:	R	Insulation:	F	Eff. Date:	04-13-2015
Field Type:		Literature:		Elec. Diagram:		Replaced By:	

Specs			
Enclosure:	DP		
Frame:	MC3212ATZ		
Frame Material:	Exposed Laminations		
Agency Approvals:	CCSA US		
Base Indicator:	Rigid		
Bearing Grease Type:	Polyrex EM (-20F +300F)		
Drip Cover:	No Drip Cover		
Duty Rating:	CONT		
Feedback Device:	NO FEEDBACK		
Field Winding Type:	STAB SHUNT		
Frame Prefix:	MC		
Heater Indicator:	No Heater		
Insulation Class:	F		
Lifting Lugs:	Standard Lifting Lugs		
Mounting Arrangement:	F2		
Shaft Extension Location:	Pulley End		

Shaft Ground Indicator:	No Shaft Grounding		
Shaft Slinger Indicator:	No Slinger		
Motor Standards:	NEMA		

Nameplate 000613006LP	
CAT.NO.	D50100RS-BV
FR	MC 3212ATZ
ENCL.	DP
ENCL MOD	FORCE VENT
MAX SAFE SPEED	3600
FIELD DATA	
WINDING	STAB SHUNT
VOLTS	300
MAX AMPS @ 25 C	3.34
HOT AMPS	2.44/ 1.91
BRUSH:419904052AB; AIR BAFFLED	
SPEC NO.	T32T1314
HP	100
RPM	1750/ 2000
VOLTS	500
AMPS	162.00
SER.NO.	
DUTY	CONT
S.F.	1.0
INSUL	F
AMB.	40
POWER CODE	C
D.E. BRG.	70BC03J30X
O.D.E. BRG.	60BC02J30X
MIN. AMB.	0
TYPE	TR

Parts List		
Part Number	Description	Quantity
SA297031	SA T32T1314	1.000 EA
AA016082	AA T32T1314	1.000 EA
000613006LP	EXTRUDER DUTY D-C MOTOR W/CSA	1.000 EA
000692000FP	NP, WARNING LIFT INSTRUCTIONS	1.000 EA
000692000FS	WARNING LABEL	1.000 EA
418057747A	METAL FASTENER	8.000 EA
406770001	C/D TAG (STAB SHUNT)	1.000 EA
036000014JB	M8 X 1.25X14MM HXHDCS	4.000 EA
036000020KB	MHHCS M10-1.5X20MM PLTD.	4.000 EA
036501009AB	M8-1.25 X 9MM HEX NUTS	8.000 EA
036600009AB	METRIC FLWASH M8 PLATED	4.000 EA
036610010AB	MHSLW M10 PLATED	4.000 EA
419904-52AB	BRUSH C	4.000 EA
419905003A	FLAT WASHER ROCKER RPM III RGG	4.000 EA
419905004A	HARDWARE	8.000 EA
706364052RC	BRHLD METRIC SPRING CHG.	4.000 EA
706372012RB	ROCKR METRIC	1.000 EA
004824015A	GREASE POLYREX EM	0.400 LB
034693001AB	PPLG - G508- use 034692001AB	1.000 EA
034693001AB	PPLG - G508- use 034692001AB	1.000 EA
035000001A	ALFTG 1/8" 1610-BL	1.000 EA
035000001BB	GREASE FTG,GRS.IN	1.000 EA
036000080KB	HHCSM10-1.5X80MMPLTD-360	3.000 EA
036100065KA	M10-1.5 X 65MM HXSOCHDCS	3.000 EA

Parts List (continued)		
Part Number	Description	Quantity
036310012FB	PHMS M4 X 12MM M2	8.000 EA
036500013AB	HX NUT,ODE BRKT	4.000 EA
036500013AB	HX NUT,ODE BRKT	4.000 EA
036501006AB	KPNUT M4 ZINC	8.000 EA
048977006C	GRFTG - XP	1.000 EA
049730000L	BPLUG	6.000 EA
400638001AF	WWSHR OS-H-KK-2	1.000 EA
412118001B	3/8-16 X 3/4 DRAIN SSTL.	1.000 EA
418057013A	GROMT	2.000 EA
418150003A	GREASE FITTING CAP	2.000 EA
609830005Y	TBOLT METRIC RP609830-	4.000 EA
706311001E	BAFFLE PLATE	1.000 EA
706311001F	BAFFLE INSULATOR	1.000 EA
706311001X	BAFLE	1.000 EA
801930052A	BRKT,ODE,C320	1.000 EA
801931060A	BRKT,DE,C320	1.000 EA
000613006NT	NAME PLATE IEC	1.000 EA
032018004CK	HHCS 3/8-16X1/2L PLATED	4.000 EA
032018006CK	HHCS 3/8-16X3/4L PLATED	4.000 EA
034017014AB	LCKW 3/8 STD. PLATED	4.000 EA
036000012HB	HHCS M6X12MM LONG PLATED	4.000 EA
036000012JB	M8-1.25 X 12MM HXHDC	3.000 EA
036000016KB	HHCSM10-1.5X16MM PLTD-280	2.000 EA
036000020JB	HHCS M8-1.25X20L PLTD-250	6.000 EA

Product Information Packet: D50100RS-BV - 100HP,1750RPM,DC,3212ATZ,DPG-FV,

036000020JB	HHCS M8-1.25X20L PLTD-250	6.000 EA
036000045HB	MHHCS M6X45MM PLATED	3.000 EA
036000045JB	M8-1.25 X 45MM HXHCS	4.000 EA
036010012GB	M5-.8 X 12 HXWHD SCREW	6.000 EA
036600009AB	METRIC FLWASH M8 PLATED	3.000 EA
036620009AB	M8 EXTERNAL LK WASHER	1.000 EA
036620010AB	M10 EXT. TOOTH LK WASHER	2.000 EA
074874025A	CBOXC, PAINTED 320	1.000 EA
402731000A	GASK 320-400	1.000 EA
410978010E	INLET FLGE	1.000 EA
410978019A	SCREEN, INLET FLANGE	1.000 EA
415000103G	TLUG	1.000 EA
417077121	FILTER KIT	1.000 EA
417733004E	GASKT	2.000 EA
418014004A	ADAPT 418014-4WCA	1.000 EA
418018070A	TAG "WARNING THERMOSTA	1.000 EA
418018074A	GROUND LABEL G100 METRIC 160 D.C.	3.000 EA
422919079	HHCVR KIT, C320, DE, SOLID	1.000 EA
422919079	HHCVR KIT, C320, DE, SOLID	1.000 EA
422919079	HHCVR KIT, C320, DE, SOLID	1.000 EA
422919090	HHCVR KIT,C320,ODE,SOLID	1.000 EA
422919090	HHCVR KIT,C320,ODE,SOLID	1.000 EA
422919101	HHCVR KIT,C320,ODE, LEXAN	1.000 EA
610409044A	ADAPT	1.000 EA
610490001DG	2HP,3450//2890RPM,3PH,60//50HZ,56C,3532M	1.000 EA
611917001H	GASKT	1.000 EA

Product Information Packet: D50100RS-BV - 100HP,1750RPM,DC,3212ATZ,DPG-FV,

611917002H	GASKT	1.000 EA
611965001A	WHEEL, BLOWER	1.000 EA
705034036A	BAFFL	1.000 EA
706303021A	GUARD	2.000 EA
706303021B	GUARD	2.000 EA
706305026A	GUARD,SHAFT	1.000 EA
706320010A	CONDUIT BOX 706320009A	1.000 EA
708528004F	HOUSING, BLOWER	1.000 EA
000640000P	TAG WINDING THERMOST	1.000 EA
000692000NG	LABEL ;NP 4POLE METRIC LABEL	1.000 EA
004824007K	SPECIAL PAINT	0.200 EA
034180032HA	KEY 5/8X5/8X4 L bin stocked	1.000 EA
418018116	WARNING PLATE	1.000 EA

609972-049

INDUSTRIAL DIRECT CURRENT MOTORS AND GENERATORS - RPM III

ENCLOSURE: DRIP-PROOF FULLY-GUARDED,
SPLASHPROOF
MOUNTING: FOOT

COOLING: FORCE VENTILATED WITH
INTEGRAL BLOWER AND
MOTOR AIR FILTERED-
SPECIAL BAFFLE

ACCESSORIES: PROVISION FOR
TACHOMETER MOUNTING
WINGNUT ONLY WHEN SPECIFIED

FRAMES SC3210ATZ THRU ULLC3612ATZ

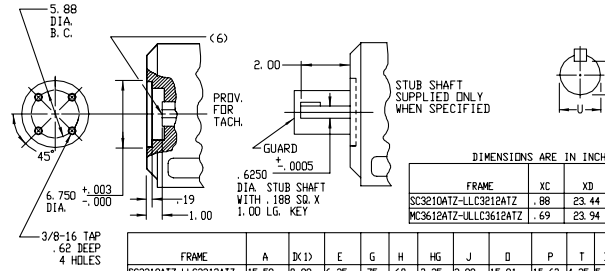
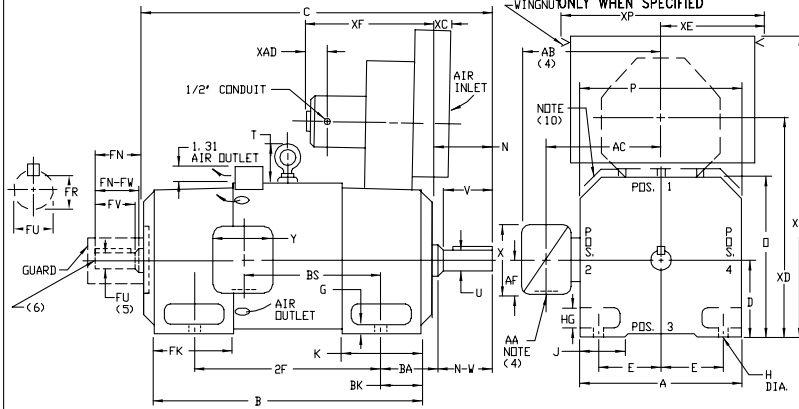

DIMENSIONS ARE IN INCHES

FRAME	XC	XD	XE	XF	XD	XP	XAD
SC3210ATZ-LLC3212ATZ	.88	23.44	11.25	17.69	38.63	22.50	3.06
MC3612ATZ-ULLC3612ATZ	.69	23.94	9.83	18.81	38.25	22.50	(11)

FRAME	A	B	D(1)	E	G	H	HG	J	D	P	T	BA	K	FK	STB.	LG(B)	BK
SC3210ATZ-LLC3212ATZ	15.50	8.00	6.25	.75	.69	2.25	3.00	15.81	15.62	4.25	6.75	7.94	10.44	4.00			
MC3612ATZ-ULLC3612ATZ	17.50	9.00	7.00	.88	.81	2.62	3.50	17.81	17.62	4.25	8.88	7.25	8.56	10.31	4.62		

FRAME	METHOD OF DRIVE	C(7)				DRIVE END SHAFT AND KEY										WT. LBS.						
		STD. LG(B)	STD. LG(B)	BS	2F	N	N-W	UK(2)	V	R(3)	SQ. LGTH.	FN	FN-FV	FK(2)	FV		FR(3)	SQ. LGTH.				
SC3210ATZ-LLC3212ATZ	(9)	36.25	38.75	28.31	30.81	13.38	20.00	5.50	5.25	2.625	5.00	2.275	625	4.00	4.75	4.50	2.250	4.25	1.972	500	3.25	1115
MC3212ATZ-LLC3212ATZ	(9)	39.25	41.75	31.31	33.81	16.38	25.00	5.50	5.25	2.625	5.00	2.275	625	4.00	4.75	4.50	2.250	4.25	1.972	500	3.25	1210
LC3212ATZ-LLC3212ATZ	(9)	41.25	43.75	33.31	35.81	18.38	25.00	5.50	5.25	2.625	5.00	2.275	625	4.00	4.75	4.50	2.250	4.25	1.972	500	3.25	1290
UMC3212ATZ-ULLC3212ATZ	BELTED	39.75	42.25	31.31	33.81	16.38	25.00	6.00	5.75	2.875	5.50	2.450	750	4.25	4.75	4.50	2.250	4.25	1.972	500	3.25	1180
MC3612ATZ-LLC3612ATZ	COUPLED	42.88	44.62	34.44	36.19	18.12	28.00	6.00	5.75	2.875	5.50	2.450	750	4.25	6.00	5.75	2.875	5.50	2.450	750	4.25	1685
UMC3612ATZ-ULLC3612ATZ	BELTED	43.62	45.38	34.44	36.19	18.12	28.00	6.75	6.50	3.250	6.25	2.831	750	5.00	6.00	5.75	2.875	5.50	2.450	750	4.25	1695
LC3612ATZ-LLC3612ATZ	COUPLED	46.62	48.38	38.19	39.94	21.88	28.00	6.00	5.75	2.875	5.50	2.450	750	4.25	6.00	5.75	2.875	5.50	2.450	750	4.25	1850
ULLC3612ATZ-ULLC3612ATZ	BELTED	47.38	49.12	38.19	39.94	21.88	28.00	6.75	6.50	3.250	6.25	2.831	750	5.00	6.00	5.75	2.875	5.50	2.450	750	4.25	1860

- (1) "D" DIMENSION WILL NOT BE EXCEEDED. SHIMS UP .06 INCHES IN THICKNESS ARE USUALLY REQUIRED FOR COUPLED OR GEARED MACHINES.
- (2) "U" AND "FU" VARY---1.000 - .001
- (3) "R" AND "FR" VARY---1.000 - .015
- (4) TERMINAL BOX VARIES WITH H.P. FOR DIMENSIONS "AA", "AB", "AC", "AF", "X" AND "Y" REFER TO BOX D/S. (STD. 609979-1, "X" 609979-2, "Y" 609979-3)
- (5) OPPOSITE DRIVE END SHAFT SUPPLIED ONLY WHEN SPECIFIED.
- (6) MOTOR SHAFT TAPPED FOR SCREW IN STUB SHAFT.
- (7) WHEN THE MOTOR APPLICATION DOES NOT REQUIRE THE USE OF DPP, DRIVE END, ADD .25 TO "C" DIM. FOR BRACKET COVER.
- (8) DIMENSION FOR FRAMES WITH PREFIX LSC, LMC, LLC, ULMC, OR ULLC.
- (9) METHOD OF DRIVE: COUPLED OR BELTED.
- (10) FOR HORIZONTAL APPLICATIONS ONLY.
- (11) "XAD" DIMENSION IS NOT APPLICABLE TO C360 FRAMES. (BLOWER MOTOR HAS CONDUIT BOX.)

BALDOR

DIMENSION DRAWING, SC3210ATZ - ULLC3612ATZ, DPP, FOOT MTG.
SH 1 of 1

CUSTOMER IS RESPONSIBLE FOR DETERMINING THAT BALDOR'S PRODUCT WILL PERFORM SUITABLY IN THE INTENDED APPLICATION.

REV. DESC: LOADED TO BUS	VERSION: 00	TDR: 000000577407
REV. LTR: -	REVISED: 01:15:54 01/26/2011	BY: CONNAS
FILE: \RGG\00015\628		
MTL: -		

609972-049

609979-001

INDUSTRIAL DIRECT CURRENT MOTORS AND GENERATORS – RPM III

STEEL AND CAST IRON TERMINAL BOX DIMENSIONS
STANDARD SIZE AND ONE SIZE LARGER
FRAMES C3210ATZ THRU C3613ATZ

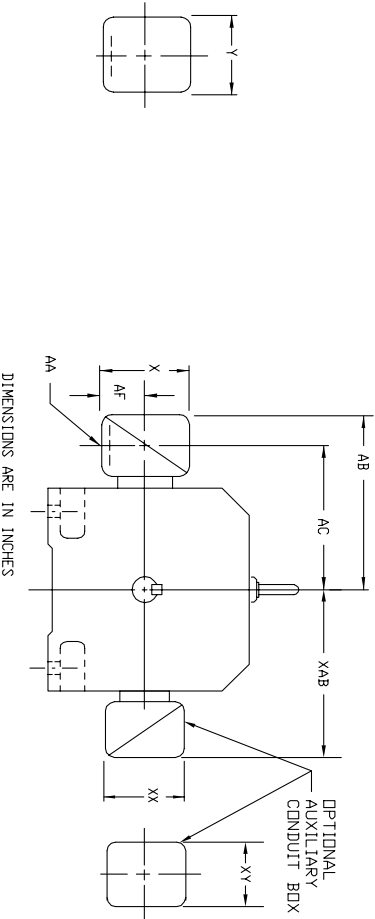

STEEL TERMINAL BOX DIMENSIONS

FRAME SIZE	MAX. AMP'S	STANDARD SIZE						PART NUMBER	ONE SIZE LARGER						PART NUMBER
		AA(1)	AB	AC	AF	X	Y		AA(1)	AB	AC	AF	X	Y	
C3210ATZ	128	2	14.88	11.38	4.25	8.44	7.25	74874-R	3	15.31	12.06	4.25	8.44	7.25	74874-24-R
C3212ATZ	185	3	15.31	12.06	4.25	8.44	7.25	74874-24-R	4	16.75	12.69	5.38	10.56	9.00	700308-3-R
C3214ATZ	269	4	16.75	12.69	5.38	10.56	9.00	700308-3-R	5	21.00	15.88	6.50	12.10	14.62	702658-1-C
	500	5	21.00	15.88	6.50	12.10	14.62	702658-1-C	5	21.00	15.88	6.50	12.10	14.62	702658-1-C
C3612ATZ	128	2	15.88	12.38	4.25	8.44	7.25	74874-R	3	16.31	13.06	4.25	8.44	7.25	74874-24-R
C3613ATZ	185	3	16.31	13.06	4.25	8.44	7.25	74874-24-R	4	17.75	13.69	5.38	10.56	9.00	700308-3-R
	269	4	17.75	13.69	5.38	10.56	9.00	700308-3-R	5	22.00	15.88	6.50	12.10	14.62	702658-1-C
	500	5	22.00	15.88	6.50	12.10	14.62	702658-1-C	5	22.00	15.88	6.50	12.10	14.62	702658-1-C

CAST IRON TERMINAL BOX DIMENSIONS

FRAME SIZE	MAX. AMP'S	STANDARD SIZE						PART NUMBER	ONE SIZE LARGER						PART NUMBER
		AA(2)	AB	AC	AF	X	Y		AA(2)	AB	AC	AF	X	Y	
C3210ATZ	128	1-1/2	13.62	11.19	3.00	6.00	7.00	75460-R	3	15.31	11.56	3.62	7.88	9.25	76700-RB
C3212ATZ	185	3	15.31	11.56	3.62	7.88	9.25	76700-RB	4	16.62	12.44	4.12	9.50	10.50	76708-RR
C3214ATZ	269	4	16.62	12.44	4.12	9.50	10.50	76708-RR	5	19.44	14.19	7.00	12.75	15.00	76870-S
	500	5	19.44	14.19	7.00	12.75	15.00	76870-S	6	19.44	14.19	7.00	12.75	15.00	76870-S
C3612ATZ	128	1-1/2	14.62	12.19	3.00	6.00	7.00	75460-R	3	16.31	12.56	3.62	7.88	9.25	76700-RB
C3613ATZ	185	3	16.31	12.56	3.62	7.88	9.25	76700-RB	4	17.62	13.44	4.12	9.50	10.50	76708-RR
	269	4	17.62	13.44	4.12	9.50	10.50	76708-RR	5	20.44	15.19	7.00	12.75	15.00	76870-S
	500	5	20.44	15.19	7.00	12.75	15.00	76870-S	6	20.44	15.19	7.00	12.75	15.00	76870-S

CONDUIT BOX DIMENSIONS WITH TERMINAL BOARDS (IEC TYPE BOX)

FRAME SIZE	AMP'S	STANDARD SIZE						PART NUMBER	ONE SIZE LARGER						PART NUMBER
		AA (3)	AB	AC	AF	X	Y		AA (3)	AB	AC	AF	X	Y	
C320	400	19.02	15.28	6.20	14.39	---	14.39	706310-63-B	14.39	14.39	---	14.39	706310-63-B		
	800	19.02	15.28	6.20	14.39	---	14.39	706310-63-B	14.39	14.39	---	14.39	706310-63-B		
	1600	19.02	15.28	6.20	14.39	---	14.39	706310-63-B	14.39	14.39	---	14.39	706310-63-B		
C360	400	20.00	15.28	6.20	14.39	---	14.39	706310-63-B	14.39	14.39	---	14.39	706310-63-B		
	800	20.00	15.28	6.20	14.39	---	14.39	706310-63-B	14.39	14.39	---	14.39	706310-63-B		
	1600	20.00	15.28	6.20	14.39	---	14.39	706310-63-B	14.39	14.39	---	14.39	706310-63-B		

FRAME SIZE	OPTIMAL AUXILIARY CONDUIT BOX DIMENSIONS (MAXIMUM)							
	XAB	XX	XY	PART NUMBER	XAB	XX	XY	PART NUMBER
C320	10.00	4.25	4.25	602007-26-A	C320	13.50	8.00	706310-3-B
C360	11.00	4.25	4.25	602007-26-A	C360	14.50	8.00	706310-3-B

- (1) AA' CONDUIT
- (2) AA' PIPE TAB
- (3) CUSTOMER TO PROVIDE HOLE FOR CONDUIT.
- TERMINAL BOX CAN BE ROTATED FOR LEAD OUTLET AT TOP, SIDES OR BOTTOM.
- TERMINAL BOX LOCATED ON OPPOSITE SIDE WHEN F-2, V-1, V-4, W-5, V-7.
- OR C-1 MOUNTING IS SPECIFIED. BOX LOCATED ON TOP WHEN SPECIFIED.
- FOR X/P TERMINAL BOX DIMENSIONS SEE 609979-05979-3.
- FOR MILL TYPE TERMINAL BOX DIMENSIONS SEE 609979-3.

100-646609

CUSTOMER IS RESPONSIBLE FOR DETERMINING THAT BALDOR'S PRODUCT WILL PERFORM SUITABLY IN THE INTENDED APPLICATION.

REV. DESC: LOAD TO BUS	VERSION: 00	TDR: 000000958110
REV. LTR: -	REVISED: 08:37:45 12/17/2015	BY: RGGWT
FILE: \\RGG\00026\318		
MTL: -		

BALDOR

DIM SHT,C3210ATZ THRU C3613ATZ,W/AUX C/BOX

SH 1 of 1

406770-001

406770-001

**CONNECTION DIAGRAM
D-C MOTOR - STAB. SHUNT**

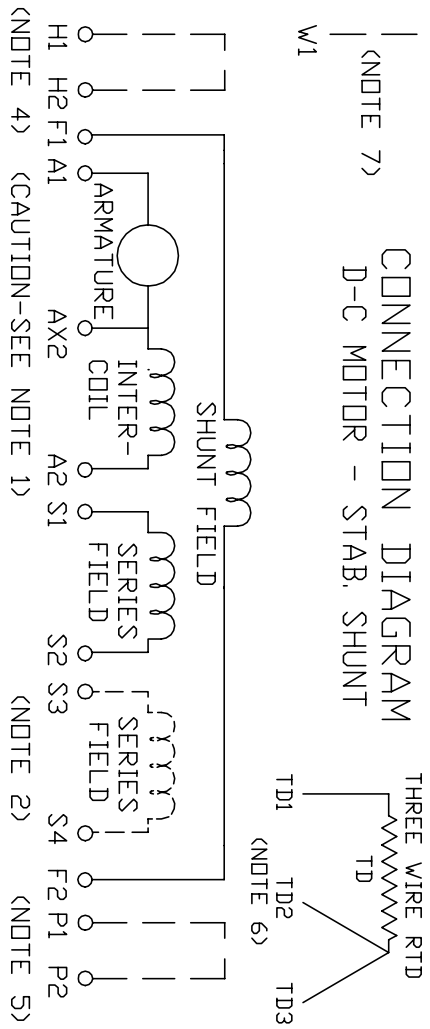

ARMATURE AND FIELD EXTERNAL CONNECTIONS
WARNING- SEE NOTE 8 FOR GROUNDING INSTRUCTIONS



ROTATION FACING COMMUTATOR END

- CAUTION** — ARMATURE AND SERIES FIELD MAY HAVE MULTIPLE LEADS. CONNECT ALL LUGS WITH THE SAME MARKING TOGETHER.
 - OPTIONAL SERIES FIELD IS MARKED S3 AND S4. FOR CUMULATIVE SERIES FIELD, CONNECT S3 TO S2 AND CONNECT S4 TO NEGATIVE. FOR DIFFERENTIAL SERIES FIELD CONNECT S4 TO S2 AND S3 TO NEGATIVE.
 - OPTIONAL CONTROL SIGNAL LEAD IS MARKED AX2. ALWAYS TAKE INTERPOLE DROP BETWEEN A2 AND AX2. NOTE: NEMA DESIGNATION FOR AX2 IS LETTER C.
 - SPACE HEATERS, WHEN PROVIDED, WILL HAVE LEADS MARKED H1 AND H2, H3, H4, ETC.
 - THERMAL PROTECTOR, WHEN PROVIDED, WILL HAVE LEADS MARKED P1 AND P2, P3, P4, ETC.
 - WINDING RTD'S, WHEN PROVIDED, WILL HAVE LEADS MARKED TD1, TD2, & TD3
 - BRUSH WEAR SENSOR, WHEN PROVIDED, WILL HAVE LEAD MARKED W1.
 - WARNING** — MOTOR MUST BE GROUNDED TO PREVENT SERIOUS INJURIES TO PERSONNEL. GROUND THE MOTOR PER IEC, NATIONAL ELECTRICAL CODE AND ANY APPLICABLE LOCAL ELECTRICAL CODES. A TAPPED HOLE IS PROVIDED IN THE CONDUIT BOX, ON THE FOOT. FRAME BRACE OR OPPOSITE DRIVE END BRACKET, ADJACENT TO THE TERMINAL BOX FOR MOTOR GROUNDING. GROUND LEAD, WHEN PROVIDED, WILL BE GREEN.
- CUSTOMER _____ RELIANCE
CUSTOMER ORDER NO. _____ S.D. NO. _____

REV. DESC: DELETED DUPLICATE WORDS FROM NOTE 8

REV. LTR: A

VERSION: 01

TDR: 000000970330

FILE: \RSN\00026\422

REVISED: 10:19:12 03/11/2016

BY: RAGTBM

MTL: -

BALDOR

D-C MOTOR CONNECTION DIAGRAM STAB. SHUNT

SH 1 of 1