

BALDOR® • RELIANCE 

Product Information Packet

D51300R-BV

300HP, 1150RPM, DC, 4013ATZ, DPG-FV,

Part Detail							
Revision:	-	Status:	PRD/A	Change #:		Proprietary:	No
Type:	DC	Prod. Type:		Elec. Spec:	G7516A A	CD Diagram:	406770-006
Enclosure:	DP	Mfg Plant:		Mech. Spec:		Layout:	609962-013
Frame:	LC401	Mounting:	F2	Poles:	00	Created Date:	04-09-2015
Base:		Rotation:	R	Insulation:	F	Eff. Date:	04-13-2015
Field Type:		Literature:		Elec. Diagram:		Replaced By:	

Specs			
Enclosure:	DP		
Frame:	LC4013ATZ		
Frame Material:	Exposed Laminations		
Agency Approvals:	CCSA US		
Base Indicator:	Rigid		
Bearing Grease Type:	Polyrex EM (-20F +300F)		
Drip Cover:	No Drip Cover		
Duty Rating:	CONT		
Feedback Device:	NO FEEDBACK		
Field Winding Type:	STR. SHUNT		
Frame Prefix:	LC		
Heater Indicator:	No Heater		
Insulation Class:	F		
Lifting Lugs:	Standard Lifting Lugs		
Mounting Arrangement:	F2		
Shaft Extension Location:	Pulley End		

Shaft Ground Indicator:	No Shaft Grounding		
Shaft Slinger Indicator:	No Slinger		
Motor Standards:	NEMA		

Nameplate 000613006HP	
CAT.NO.	D51300R-BV
FR	LC 4013ATZ
ENCL.	DP
ENCL MOD	FORCE VENT
MAX SAFE SPEED	3000
FIELD DATA	
WINDING	STR. SHUNT
VOLTS	300
MAX AMPS @ 25 C	13.20
HOT AMPS	9.27/ 4.87
	BRUSH:419904052AA

SPEC NO.	T40S1320
HP	300
RPM	1150/ 2000
VOLTS	500
AMPS	485.00
SER.NO.	
DUTY	CONT
S.F.	1.0
INSUL	F
AMB.	40
POWER CODE	C
D.E. BRG.	95BC02J30X
O.D.E. BRG.	95BC02J30X
MIN. AMB.	0
TYPE	TR

Parts List		
Part Number	Description	Quantity
SA297000	SA T40S1320	1.000 EA
AA016051	AA T40S1320	1.000 EA
000613006HP	NAMEPLATE - RPM III D-C MOTOR W/CSA LOGO	1.000 EA
000692000FP	NP, WARNING LIFT INSTRUCTIONS	1.000 EA
000692000FS	WARNING LABEL	1.000 EA
418057747A	METAL FASTENER	8.000 EA
406770006	C/D TAG STRAIGHT SHUNT	1.000 EA
036000014JB	M8 X 1.25X14MM HXHDCS	4.000 EA
036000020KB	MHHCS M10-1.5X20MM PLTD.	4.000 EA
036501009AB	M8-1.25 X 9MM HEX NUTS	8.000 EA
036600009AB	METRIC FLWASH M8 PLATED	4.000 EA
036610010AB	MHSLW M10 PLATED	4.000 EA
419904052AA	BRUSH C	16.000 EA
419905003A	FLAT WASHER ROCKER RPM III RGG	4.000 EA
419905004A	HARDWARE	8.000 EA
706364052RL	BRHLD METRIC SPRING CHG.	4.000 EA
706372015RA	ROCKR C400	1.000 EA
004824015A	GREASE POLYREX EM	0.900 LB
034693001AB	PPLG - G508- use 034692001AB	1.000 EA
034693001AB	PPLG - G508- use 034692001AB	1.000 EA
035000001A	ALFTG 1/8" 1610-BL	1.000 EA
035000001BB	GREASE FTG,GRS.IN	1.000 EA
036000075KB	HHCS M10 75MM ZINCPLAT	4.000 EA
036100100KA	SHCS BRACKET LE	4.000 EA

Parts List (continued)		
Part Number	Description	Quantity
036500013AB	HX NUT,ODE BRKT	4.000 EA
036500013AB	HX NUT,ODE BRKT	4.000 EA
418150003A	GREASE FITTING CAP	2.000 EA
419912001B	W WASHER	1.000 EA
609830005AL	TBOLT METRIC C400	4.000 EA
801934002A	BRKT,ODE,C400	1.000 EA
801935002A	BRKT,DE,C400	1.000 EA
000613006NT	NAME PLATE IEC	1.000 EA
032018004CK	HHCS 3/8-16X1/2L PLATED	4.000 EA
032018006CK	HHCS 3/8-16X3/4L PLATED	4.000 EA
034017014AB	LCKW 3/8 STD. PLATED	4.000 EA
036000012JB	M8-1.25 X 12MM HXHDC	3.000 EA
036000016KB	HHCSM10-1.5X16MM PLTD-280	2.000 EA
036000020JB	HHCS M8-1.25X20L PLTD-250	2.000 EA
036000020JB	HHCS M8-1.25X20L PLTD-250	6.000 EA
036000045JB	M8-1.25 X 45MM HXHCS	2.000 EA
036000060KB	HHCS,DE CAP	4.000 EA
036601009AB	M8 FLAT WASHER	2.000 EA
036601009AB	M8 FLAT WASHER	2.000 EA
036610009AB	MHSLW M8 SPL.PLTD-G508- BS	2.000 EA
036610009AB	MHSLW M8 SPL.PLTD-G508- BS	2.000 EA
036620010AB	M10 EXT. TOOTH LK WASHER	1.000 EA
036620010AB	M10 EXT. TOOTH LK WASHER	2.000 EA
410978010F	FLANGE, INLET BLOWER HSG	1.000 EA

Product Information Packet: D51300R-BV - 300HP,1150RPM,DC,4013ATZ,DPG-FV,

410978015A	GRILL, INLET FLANGE	1.000 EA
415000103F	TLUG	1.000 EA
417537001A	CLAMP PLATE (MTR LEADS)	1.000 EA
417733010B	GASKT	2.000 EA
418010015A	ADAPT C/BOX BASE	1.000 EA
418018074A	GROUND LABEL G100 METRIC 160 D.C.	4.000 EA
422913001A	SUPRT, LEAD CLAMP C400 ST	1.000 EA
422919131	HHCVR KIT,C400, DE, SOLID	1.000 EA
422919133	HHCVR KIT,C400,DE,LOUVERED	1.000 EA
422919133	HHCVR KIT,C400,DE,LOUVERED	1.000 EA
422919142	HHCVR KIT,C400,ODE,SOLID	1.000 EA
422919142	HHCVR KIT,C400,ODE,SOLID	1.000 EA
610490002JM	BLOWER MOTOR	1.000 EA
611917002N	GASKT C400	1.000 EA
611965001E	BLOWER WHEEL	1.000 EA
706305026A	GUARD,SHAFT	1.000 EA
706310015A	CBOX C400	1.000 EA
706313062A	BLOWER HOUSING	1.000 EA
000640000P	TAG WINDING THERMOST	1.000 EA
000692000NG	LABEL ;NP 4POLE METRIC LABEL	1.000 EA
004824007K	SPECIAL PAINT	0.300 EA
034180046KA	KEY 7/8X7/8X5-3/4L	1.000 EA
418018071	LABEL LABE	1.000 EA

609962-013

INDUSTRIAL DIRECT CURRENT MOTORS AND GENERATORS - RPM III

ENCLOSURE: DRIP-PROOF FULLY-GUARDED
SPLASHPROOF

COOLING: FORCE VENTILATED
WITH INTEGRAL
BLOWER AND MOTOR
ACCESSORIES: PROVISION FOR
TACHOMETER MOUNTING
ONLY WHEN SPECIFIED

FRAMES C4011ATZ THRU ULC4013ATZ

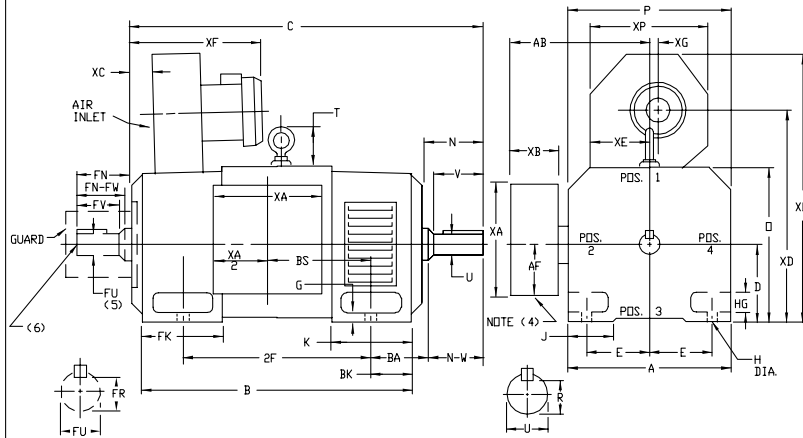

DIMENSIONS ARE IN INCHES

FRAME	A	D(1)	E	G	H	HG	J	D	P	T	BA	K	FK	BK	AB	AF	RH(6)
C4011ATZ-ULC4013ATZ	19.38	10.00	8.00	1.06	1.06	2.82	3.50	19.81	19.56	4.31	6.62	8.75	12.12	5.25	16.12	8.00	.6240

FRAME	METHOD OF DRIVE	C(7)	B	BS	2F	N	N-W	UC(2)	V	R(3)	SO	LGTH	FN	FN-FW	FK(2)	FV	FR(3)	SO	LGTH	WT. LBS.
C4011ATZ	COUPLED	52.19	42.06	16.00	28.00	7.62	7.25	3.625	7.00	3.134	.875	5.75	7.62	7.25	3.625	7.00	3.134	.875	5.75	2500
UC4011ATZ	BELTED	53.19	42.06	16.00	28.00	8.62	8.25	4.125	8.00	3.563	1.000	6.50	7.62	7.25	3.625	7.00	3.134	.875	5.75	2505
MC4013ATZ	COUPLED	56.94	46.81	20.75	36.00	7.62	7.25	3.625	7.00	3.134	.875	5.75	7.62	7.25	3.625	7.00	3.134	.875	5.75	2800
UMC4013ATZ	BELTED	57.94	46.81	20.75	36.00	8.62	8.25	4.125	8.00	3.563	1.000	6.50	7.62	7.25	3.625	7.00	3.134	.875	5.75	2805
LC4013ATZ	COUPLED	60.19	50.06	24.00	36.00	7.62	7.25	3.625	7.00	3.134	.875	5.75	7.62	7.25	3.625	7.00	3.134	.875	5.75	3100
ULC4013ATZ	BELTED	61.19	50.06	24.00	36.00	8.62	8.25	4.125	8.00	3.563	1.000	6.50	7.62	7.25	3.625	7.00	3.134	.875	5.75	3105

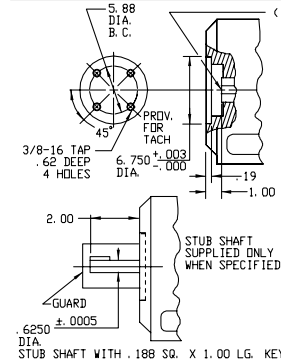

FRAME	XA	XB	XC	XD	XE	XF	XG	XD	XP
C4011ATZ-ULC4013ATZ	16.00	6.00	6.88	26.00	8.69	23.50	3.38	33.62	15.12

- (1) "D" DIMENSION WILL NOT BE EXCEEDED. SHIMS UP TO .06 INCHES IN THICKNESS ARE USUALLY REQUIRED FOR COUPLED OR GEARED MACHINES.
- (2) "UP" AND "FU" VARY ----+.000 -.001
- (3) "R" AND "FR" VARY ----+.000 -.015
- (4) CUSTOMER TO PROVIDE HOLE IN TERMINAL BOX FOR CONDUIT.
- (5) OPPOSITE DRIVE END SHAFT SUPPLIED ONLY WHEN SPECIFIED.
- (6) MOTOR SHAFT TAPPED FOR SCREW IN STUB SHAFT
- (7) WHEN THE MOTOR APPLICATION DOES NOT REQUIRE THE USE OF DPP, DRIVE END, ADD .25 TO "C" DIM. FOR BRACKET COVER.

TERMINAL BOX LOCATED ON OPPOSITE SIDE WHEN F-2, W-1, W-4, W-5, W-7, OR C-1 MOUNTING IS SPECIFIED. BOX LOCATED ON TOP WHEN SPECIFIED. BLOWER ASSEMBLY CAN BE LOCATED AT POSITIONS 1, 2, OR 4, EXCEPT BLOWER ASSEMBLY AND TERMINAL BOX CAN NOT BE LOCATED AT THE SAME POSITION. MOTOR WEIGHT MAY VARY 13% FOR NON-STANDARD RATINGS AND/OR ACCESSORIES. IF MOUNTING CLEARANCE DETAILS ARE REQUIRED, CONSULT FACTORY.

CUSTOMER IS RESPONSIBLE FOR DETERMINING THAT BALDOR'S PRODUCT WILL PERFORM SUITABLY IN THE INTENDED APPLICATION.

REV. DESC: LOADED TO BUS	VERSION: 00	TDR: 000000577407
REV. LTR: -	REVISED: 12:04:54 01/26/2011	BY: CONNAS
FILE: \RGG\00015\600		
MTL: -		

BALDOR
DIMENSION DRAWING, C4011ATZ - ULC4013ATZ, DPP, FOOT MTG.
SH 1 of 1

609962-013

406770-006

406770-006

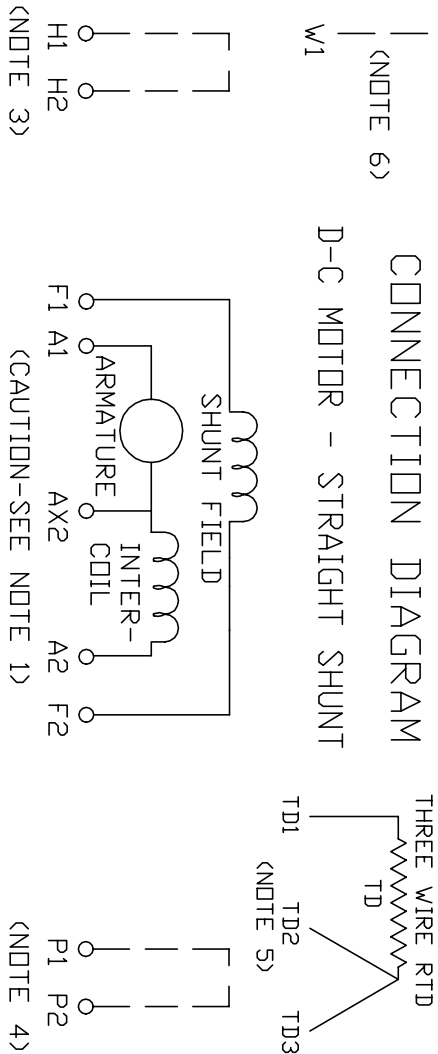

1. **CAUTION** — ARMATURE MAY HAVE MULTIPLE LEADS. CONNECT ALL LUGS WITH THE SAME MARKING TOGETHER.
2. OPTIONAL CONTROL SIGNAL LEAD IS MARKED AX2. ALWAYS TAKE INTERPOLE DROP BETWEEN A2 AND AX2. NOTE: NEMA DESIGNATION FOR AX2 IS LETTER C.
3. SPACE HEATERS, WHEN PROVIDED, WILL HAVE LEADS MARKED H1 AND H2, H3, H4, ETC.
4. THERMAL PROTECTOR, WHEN PROVIDED, WILL HAVE LEADS MARKED P1 AND P2, P3, P4, ETC.
5. WINDING RTD'S, WHEN PROVIDED, WILL HAVE LEADS MARKED TD1, TD2, & TD3.
6. BRUSH WEAR SENSOR, WHEN PROVIDED, WILL HAVE LEAD MARKED W1.
7. **WARNING** — MOTOR MUST BE GROUNDED TO PREVENT SERIOUS INJURIES TO PERSONNEL. GROUND THE MOTOR PER IEC, NATIONAL ELECTRICAL CODE AND ANY APPLICABLE LOCAL ELECTRICAL CODES. A TAPPED HOLE IS PROVIDED IN THE CONDUIT BOX, ON THE FOOT. FRAME BRACE OR OPPOSITE OPPOSITE DRIVE END BRACKET, ADJACENT TO THE TERMINAL BOX FOR FOR MOTOR GROUNDING. GROUND LEAD, WHEN PROVIDED, WILL BE GREEN.

CUSTOMER _____ RELIANCE
ORDER NO. _____ S.D. NO. _____

REV. DESC: UPDATE LOGO AND TITLEBLOCK: LOADED TO BUS		
REV. LTR: -	VERSION: 00	TDR: 000000781086
FILE: \RSN\00026\515	REVISED: 02: 41: 08 02/01/2013	
MTL: -	BY: MGHPC	

BALDOR
D-C MOTOR CONNECTION DIAGRAM, STRAIGHT SHUNT
SH 1 of 1