

BALDOR® • RELIANCE 

Product Information Packet

D5510R

10HP, 1750RPM, DC, 2113ATY, TEFC,

Part Detail							
Revision:	-	Status:	PRD/A	Change #:		Proprietary:	No
Type:	DC	Prod. Type:		Elec. Spec:	G6142B A	CD Diagram:	406770-002
Enclosure:	TEFC	Mfg Plant:		Mech. Spec:		Layout:	609951-013
Frame:	MC211	Mounting:	F1	Poles:	00	Created Date:	04-10-2015
Base:		Rotation:	R	Insulation:	F	Eff. Date:	04-13-2015
Field Type:		Literature:		Elec. Diagram:		Replaced By:	

Specs			
Enclosure:	TEFC		
Frame:	MC2113ATZ		
Frame Material:	Exposed Laminations		
Agency Approvals:	CCSA US		
Base Indicator:	Rigid		
Bearing Grease Type:	Polyrex EM (-20F +300F)		
Drip Cover:	No Drip Cover		
Duty Rating:	CONT		
Feedback Device:	NO FEEDBACK		
Field Winding Type:	STAB SHUNT		
Frame Prefix:	MC		
Heater Indicator:	No Heater		
Insulation Class:	F		
Lifting Lugs:	Standard Lifting Lugs		
Mounting Arrangement:	F1		
Shaft Extension Location:	Pulley End		

Shaft Ground Indicator:	No Shaft Grounding		
Shaft Slinger Indicator:	No Slinger		
Motor Standards:	NEMA		

Nameplate 000613006HP			
CAT.NO.	D5510R	SPEC NO.	T21S0304
FR	MC 2113ATZ	HP	10
ENCL.	TEFC	DUTY	CONT
ENCL MOD		RPM	1750/ 2300
MAX SAFE SPEED	4500	VOLTS	500
		S.F.	1.0
		AMPS	17.50
		INSUL	F
		AMB.	40
		SER.NO.	
		POWER CODE	C
		D.E. BRG.	50BC03J30X
		O.D.E. BRG.	45BC02J30X
		MIN. AMB.	0
			TYPE TR
			150/300

FIELD DATA	
WINDING	STAB SHUNT
VOLTS	300
MAX AMPS @ 25 C	1.55
HOT AMPS	1.06/ .76
	BRUSH:419904051E; FLD. DATA
	FOR HIGH VOLTS; FIELD VOLTS

Parts List		
Part Number	Description	Quantity
SA297167	SA T21S0304	1.000 EA
AA016180	AA T21S0304	1.000 EA
000613006HP	NAMEPLATE - RPM III D-C MOTOR W/CSA LOGO	1.000 EA
000692000FP	NP, WARNING LIFT INSTRUCTIONS	1.000 EA
000692000FS	WARNING LABEL	1.000 EA
036170004EA	ROUND HEAD DRIVE SCREW	6.000 EA
406770002	C/D TAG STAB SHUNT D.V.	1.000 EA
036000012HB	HHCS M6X12MM LONG PLATED	4.000 EA
036000020KB	MHHCS M10-1.5X20MM PLTD.	4.000 EA
036501008AB	KPNUT M6-1.0 ZINCPLETED	8.000 EA
036610010AB	MHSLW M10 PLATED	4.000 EA
419904051E	BRUSH N	4.000 EA
419905003A	FLAT WASHER ROCKER RPM III RGG	4.000 EA
419905008A	HARDWARE	8.000 EA
706364051AA	BRHLD ADD HARDWARE	4.000 EA
706372001B	ROCKR METRIC	1.000 EA
034530018AB	P/NIP 1/8X2-1/4L PLATED	1.000 EA
034630001AJ	1/8" PIPE COUPLING	1.000 EA
034693001AB	PPLG - G508- use 034692001AB	1.000 EA
034693001AB	PPLG - G508- use 034692001AB	1.000 EA
035000001A	ALFTG 1/8" 1610-BL	1.000 EA
035000001A	ALFTG 1/8" 1610-BL	1.000 EA
036000055JB	HHCS,DE CAP	2.000 EA
036000060KB	HHCS,DE CAP	3.000 EA

Parts List (continued)		
Part Number	Description	Quantity
036500010AB	METRIC NUT M10-1.5PLTD400	4.000 EA
036500010AB	METRIC NUT M10-1.5PLTD400	4.000 EA
048977006B	GRFTG - XP	1.000 EA
400638001H	SPRING WASHER	1.000 EA
418150003A	GREASE FITTING CAP	2.000 EA
609830005N	TBOLT METRIC RP609830-	4.000 EA
801924102E	BRKT,ODE,C210	1.000 EA
801925102A	BRKT,DE,C210	1.000 EA
032018004AK	HHCS 1/4-20X1/2 PLATED	4.000 EA
032018004CK	HHCS 3/8-16X1/2L PLATED	3.000 EA
032018014DK	HHCS 1/2-13X1-3/4 PLTD	4.000 EA
034001012AB	WSHR 1/4" PLATED	4.000 EA
034017016AB	LCKW 1/2" PLATED	4.000 EA
034180012EA	KEY 5/16X5X16X1-1/2 L	1.000 EA
036000012HB	HHCS M6X12MM LONG PLATED	2.000 EA
036000045JB	M8-1.25 X 45MM HXHCS	4.000 EA
036620009AB	M8 EXTERNAL LK WASHER	1.000 EA
065530000B	GASK	1.000 EA
075451000A	COVER, CONDUIT BOX	1.000 EA
078547001R	FAN A 78547001P	1.000 EA
412043012B	400G BUTTON	1.000 EA
415072001B	CLAMP	1.000 EA
417733001G	GASKT	2.000 EA
418010006A	CAST,MPLATE,180-280,EX1,7BY	1.000 EA

Product Information Packet: D5510R - 10HP,1750RPM,DC,2113ATY,TEFC,

418018074A	GROUND LABEL G100 METRIC 160 D.C.	1.000 EA
422919001	CVRKT BE SOLID C210	1.000 EA
422919001	CVRKT BE SOLID C210	1.000 EA
422919001	CVRKT BE SOLID C210	1.000 EA
422919012	HHCVR KIT,C210,ODE,SOLID	1.000 EA
422919012	HHCVR KIT,C210,ODE,SOLID	1.000 EA
422919012	HHCVR KIT,C210,ODE,SOLID	1.000 EA
603909002A	GRILL, FAN	1.000 EA
706320003A	CONDUIT BOX	1.000 EA
706365001A	FNGRL	1.000 EA
801953001A	FNCVR	1.000 EA
000640000P	TAG WINDING THERMOST	1.000 EA
000692000NG	LABEL ;NP 4POLE METRIC LABEL	1.000 EA
034180020GA	KEY 1/2X1/2X2-1/2 L	1.000 EA

609951-013

INDUSTRIAL DIRECT CURRENT MOTORS AND GENERATORS - RPM III

ENCLOSURE: TOTALLY ENCLOSED
MOUNTING: FOOT
METHOD OF DRIVE: COUPLED OR BELTED

COOLING: FAN COOLED
ACCESSORIES: PROVISION FOR
TACHOMETER MOUNTING
ONLY WHEN SPECIFIED

FRAMES SC2113ATZ THRU LC2812ATZ

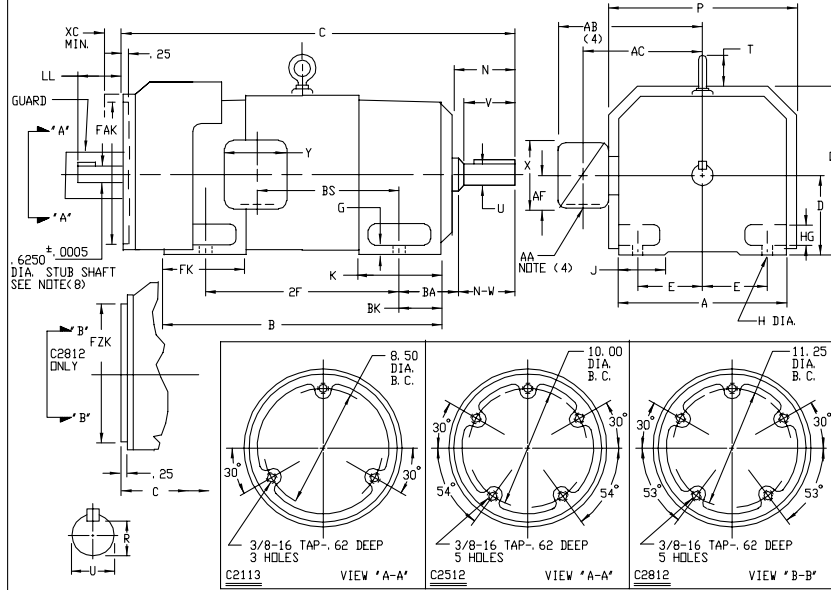

DIMENSIONS ARE IN INCHES

FRAME	A	B(1)	E	G	H	HG	J	D	P	T	BA	K	FK	BK	FAK(6)	FZK(7)	XC(5)
SC2113ATZ-LC2113ATZ	10.25	5.25	4.25	.44	.44	1.38	1.75	11.62	12.75	1.38	3.50	5.19	6.81	2.38	9.750	N/A	1.25
SC2512ATZ-LC2512ATZ	12.31	6.25	5.00	.50	.56	1.62	2.00	13.62	14.75	1.94	4.25	6.06	8.00	3.00	11.250	N/A	1.25
MC2812ATZ-LC2812ATZ	13.78	7.00	5.50	.62	.56	1.88	2.75	15.06	16.12	2.31	4.75	6.75	9.19	3.50	N/A	12.500	1.25

FRAME	C	B	BS	ZF	DRIVE END SHAFT AND KEY				WT.			
					N	N-V	UK(2)	V		RC(3)	SD	LGTH.
SC2113ATZ	32.19	22.50	11.38	18.00	4.00	3.75	1.875	3.50	1.591	500	2.50	355
MC2113ATZ	33.44	23.75	12.62	18.00	4.00	3.75	1.875	3.50	1.591	500	2.50	380
LC2113ATZ	35.06	25.38	14.25	18.00	4.00	3.75	1.875	3.50	1.591	500	2.50	410
SC2512ATZ	35.94	25.06	12.06	20.00	4.50	4.25	2.125	4.00	1.845	500	3.00	355
MC2512ATZ	37.44	26.56	13.56	20.00	4.50	4.25	2.125	4.00	1.845	500	3.00	590
LC2512ATZ	38.94	28.06	15.06	20.00	4.50	4.25	2.125	4.00	1.845	500	3.00	630
MC2812ATZ	41.62	29.94	14.25	22.00	5.00	4.75	2.375	4.50	2.021	625	3.50	835
LC2812ATZ	43.88	32.19	16.50	22.00	5.00	4.75	2.375	4.50	2.021	625	3.50	900

- (1) 'B' DIMENSION WILL NOT BE EXCEEDED. SHIMS UP TO .03 INCHES IN THICKNESS ARE USUALLY REQUIRED FOR COUPLED OR GEARED MACHINES.
 - (2) 'U' VARIES----4.000 - .001
 - (3) 'R' VARIES----4.000 - .015
 - (4) TERMINAL BOX VARIES WITH H.P. FOR DIMENSIONS 'AA', 'AB', 'AC', 'AF', 'X' AND 'Y'. SEE DRAWING NUMBER 609959-1.
 - (5) WALLS OR OBSTRUCTIONS MUST NOT ENCRDACH ON AIR INLET SPACE 'XC'.
 - (6) 'FAK' VARIES + .005 - .000----FACE RUNDUT AND ECCENTRICITY .007 MAX. T. I. R.
 - (7) 'FZK' VARIES + .000 - .005----FACE RUNDUT AND ECCENTRICITY .007 MAX. T. I. R.
 - (8) STUB SHAFT SUPPLIED ONLY WHEN SPECIFIED. KEY SIZE .188 X .188 X 1.00
 - (9) FOR RE-045 DR SPY PROVISIONS ON 'C2812' ADD 1.00 TO 'LL' DIMENSION.
- TERMINAL BOX CAN BE ROTATED FOR LEAD OUTLET AT TOP, SIDES OR BOTTOM
TERMINAL BOX LOCATED ON OPPOSITE SIDE WHEN F-2, W-1, W-4, W-5, W-7,
DR, C-1 MOUNTING IS SPECIFIED. BOX LOCATED ON TOP WHEN SPECIFIED.
MOTOR WEIGHT MAY VARY 15% FOR NON-STANDARD RATINGS AND/OR ACCESSORIES.
IF MOUNTING CLEARANCE DETAILS ARE REQUIRED, CONSULT FACTORY.

TACHOMETER	LL
BC-42	4.25
BC-46	
RD-11	
RD-12	
RD-51	
RD-61	
RD-62	
RE-210	
M627, M628	
M727, M737	
M738	3.80
DINAPAR 745	
RE-045	1.12
SPY	SEE NOTE (9)

CUSTOMER IS RESPONSIBLE FOR DETERMINING THAT BALDOR'S PRODUCT WILL PERFORM SUITABLY IN THE INTENDED APPLICATION.

REV. DESC: LOADED TO BUS	VERSION: 00	TDR: 000000577407
REV. LTR: -	REVISED: 11:02:01 01/26/2011	BY: CONNAS
FILE: \RGG\00015\557		
MTL: -		

BALDOR
DIMENSION DRAWING, SC2113ATZ - LC2812ATZ, TEFC, FOOT MTG
SH 1 of 1

609951-013

609959-001

INDUSTRIAL DIRECT CURRENT MOTORS
AND GENERATORS - RPM III
TERMINAL BOX DIMENSIONS
STANDARD SIZE AND ONE SIZE LARGER
FRAMES C2113ATZ THRU C2815ATZ

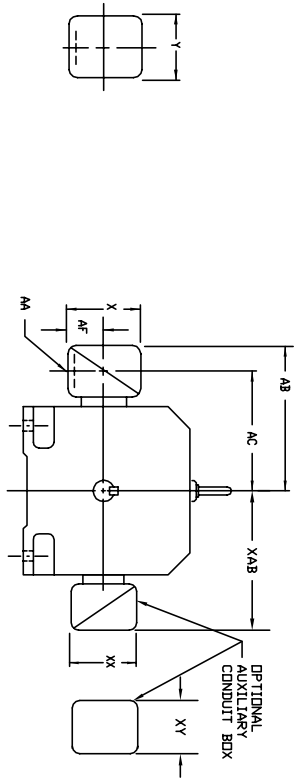

DIMENSIONS ARE IN INCHES

FRAME SIZE	STANDARD SIZE						ONE SIZE LARGER								
	MAX. AMPS	AK(1)	AB	AC	AF	PART NUMBER	AK(1)	AB	AC	AF	PART NUMBER				
C2113ATZ	40	3/4 & 1"	8.97	7.47	1.94	4.38	5.00	7.05028-1-R	1-1/4 & 1-1/2	10.03	8.03	2.50	5.50	6.12	7.05029-1-R
C2115ATZ	96	1-1/4 & 1-1/2	10.03	8.03	2.50	5.50	6.12	7.05029-1-R	2" & 2-1/2	11.16	8.41	3.19	7.00	7.62	7.05030-1-R
(2)	208	2" & 2-1/2	11.16	8.41	3.19	7.00	7.62	7.05030-1-R	2" & 2-1/2	11.16	8.41	3.19	7.00	7.62	7.05030-1-R
C2513ATZ	40	3/4 & 1"	10.03	8.53	1.94	4.38	5.00	7.05029-1-R	1-1/4 & 1-1/2	11.09	9.09	2.50	5.50	6.12	7.05029-1-R
C2515ATZ	96	1-1/4 & 1-1/2	11.09	9.09	2.50	5.50	6.12	7.05029-1-R	2" & 2-1/2	12.22	9.47	3.19	7.00	7.62	7.05030-1-R
(2)	208	2" & 2-1/2	12.22	9.47	3.19	7.00	7.62	7.05030-1-R	2" & 2-1/2	12.22	9.47	3.19	7.00	7.62	7.05030-1-R
C2813ATZ	128	2"	14.03	10.53	4.25	8.44	7.25	7.4874-R	3"	14.47	11.22	4.25	8.44	7.25	7.4874-R
C2815ATZ	185	3"	14.47	11.22	4.25	8.44	7.25	7.4874-R	4"	15.91	11.84	5.38	10.56	9.00	7.0308-3-R
(2)	259	4"	15.91	11.84	5.38	10.56	9.00	7.0308-3-R	5" (4)	18.72	13.47	7.00	12.75	15.00	7.02658-1-C

FRAME SIZE	STANDARD SIZE						ONE SIZE LARGER								
	MAX. AMPS	AK(3)	AB	AC	AF	PART NUMBER	AK(3)	AB	AC	AF	PART NUMBER				
C2113ATZ	18	3/4	10.03	8.03	2.50	5.00	5.75	7.05028-2-S	1-1/2	10.03	8.03	2.50	5.00	5.75	7.05028-2-T
C2115ATZ	40	1"	10.03	8.03	2.50	5.00	5.75	7.05028-2-R	1-1/2	10.97	8.53	3.00	6.00	7.00	7.05029-2-S
(2)	96	1-1/2	10.97	8.53	3.00	6.00	7.00	7.05029-2-R	2-1/2	12.66	8.91	3.62	7.88	9.23	7.05029-2-S
208	3/4	10.97	8.53	3.00	6.00	7.00	7.05029-2-S	1"	11.09	9.09	2.50	5.00	5.75	7.05028-2-T	
C2513ATZ	40	1"	11.09	9.09	2.50	5.00	5.75	7.05028-2-T	1-1/2	12.03	9.59	3.00	6.00	7.00	7.05029-2-R
C2515ATZ	96	1-1/2	12.03	9.59	3.00	6.00	7.00	7.05029-2-R	2"	12.03	9.59	3.00	6.00	7.00	7.05029-2-S
(2)	208	2"	12.03	9.59	3.00	6.00	7.00	7.05029-2-S	1-1/2	12.03	9.59	3.00	6.00	7.00	7.05029-2-R
C2813ATZ	128	2"	12.78	10.34	3.00	6.00	7.00	7.5460-T	3"	14.47	10.72	3.62	7.88	9.23	7.6700-R
C2815ATZ	185	3"	14.47	10.72	3.62	7.88	9.23	7.6700-R	4"	15.78	11.59	4.12	9.50	10.50	7.6700-R
(2)	259	4"	15.78	11.59	4.12	9.50	10.50	7.6700-R	5" (4)	18.59	13.34	7.00	12.75	15.00	7.6870-S

FRAME SIZE	STANDARD SIZE						ONE SIZE LARGER					
	AMP(S)	AB	AC	AF	X	Y	AB	AC	AF	X	Y	
C210	100	10.71	8.98	2.72	7.48	7.48	7.48	7.48	7.48	7.48	7.48	
200	11.26	9.25	3.35	8.82	8.82	8.82	7.48	7.48	7.48	7.48	7.48	
100	11.30	9.57	2.72	7.48	7.48	7.48	7.48	7.48	7.48	7.48	7.48	
200	11.85	9.84	3.35	8.82	8.82	8.82	7.48	7.48	7.48	7.48	7.48	
400	17.48	12.75	6.20	14.39	14.39	14.39	7.48	7.48	7.48	7.48	7.48	
800	17.48	12.75	6.20	14.39	14.39	14.39	7.48	7.48	7.48	7.48	7.48	
200	12.60	10.99	3.76	8.82	8.82	8.82	7.48	7.48	7.48	7.48	7.48	
400	18.27	13.54	6.20	14.39	14.39	14.39	7.48	7.48	7.48	7.48	7.48	
800	18.27	13.54	6.20	14.39	14.39	14.39	7.48	7.48	7.48	7.48	7.48	
1600	18.27	13.54	7.68	15.35	15.35	15.35	7.48	7.48	7.48	7.48	7.48	

(1) *AM. CONDUIT
(2) STEEL TERMINAL BOX FOR C2113ATZ AND C251ATZ
(3) *AM. PIPE TAP
(4) TERMINAL BOX 76870-9R EXTENDS BELOW MOTOR FEET.
TERMINAL BOX CAN BE ROTATED FOR LEAD DULLET AT TOP, SIDES OR BOTTOM.
TERMINAL BOX LOCATED ON OPPOSITE SIDE WHEN F-2, V-1, V-4, V-5, V-7,
OR C-1 MOUNTING IS SPECIFIED. BOX LOCATED ON TOP WHEN SPECIFIED.
FOR *X/P TERMINAL BOX DIMENSIONS SEE 609959-2.
FOR **X/P TERMINAL BOX DIMENSIONS SEE 609959-3.

CUSTOMER IS RESPONSIBLE FOR DETERMINING THAT BALDOR'S PRODUCT WILL PERFORM SUITABLY IN THE INTENDED APPLICATION.

REV. DESC: ADD 706310-63G C/BOX TO C250 AND C280 FRAMES	VERSION: 01	TDR: 000000816512
REV. LTR: A		
FILE: \RGG\00021\153		REVISED: 03:09:09 09/06/2013
MTL: -		BY: RGGWT



DIMENSION SHEET
SH 1 of 1

609959-001

406770-002

406770-002

CONNECTION DIAGRAM
D-C MOTOR - STAB, SHUNT
DUAL VOLTAGE FIELD

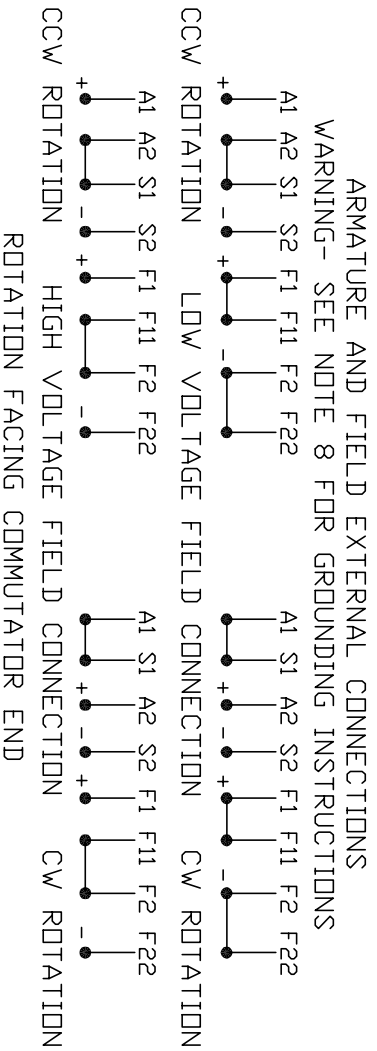
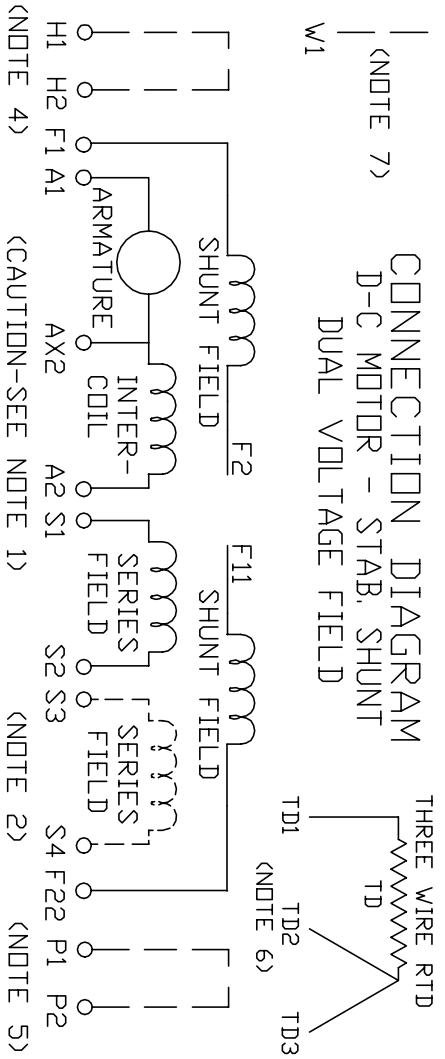

- CAUTION** - ARMATURE AND SERIES FIELD MAY HAVE MULTIPLE LEADS. CONNECT ALL LUGS WITH THE SAME MARKING TOGETHER.
 - OPTIONAL SERIES FIELD IS MARKED S3 AND S4. FOR CUMULATIVE SERIES FIELD, CONNECT S3 TO S2 AND CONNECT S4 TO NEGATIVE. FOR DIFFERENTIAL SERIES FIELD CONNECT S4 TO S2 AND S3 TO NEGATIVE.
 - OPTIONAL CONTROL SIGNAL LEAD IS MARKED AX2. ALWAYS TAKE INTERPOLE DROP BETWEEN A2 AND AX2. NOTE: NEMA DESIGNATION FOR AX2 IS LETTER C.
 - SPACE HEATERS, WHEN PROVIDED, WILL HAVE LEADS MARKED H1 AND H2, H3, H4, ETC.
 - THERMAL PROTECTOR, WHEN PROVIDED, WILL HAVE LEADS MARKED P1 AND P2, P3, P4, ETC.
 - WINDING RTD'S, WHEN PROVIDED, WILL HAVE LEADS MARKED TD1, TD2, & TD3
 - BRUSH WEAR SENSOR, WHEN PROVIDED, WILL HAVE LEAD MARKED W1.
 - WARNING** - MOTOR MUST BE GROUNDED TO PREVENT SERIOUS INJURIES TO PERSONNEL. GROUND THE MOTOR PER IEC, NATIONAL ELECTRICAL CODE AND ANY APPLICABLE LOCAL ELECTRICAL CODES. A TAPPED HOLE IS PROVIDED IN THE CONDUIT BOX, ON THE FOOT. FRAME BRACE OR OPPOSITE OPPOSITE DRIVE END BRACKET, ADJACENT TO THE TERMINAL BOX FOR FOR MOTOR GROUNDING. GROUND LEAD, WHEN PROVIDED, WILL BE GREEN.
- CUSTOMER _____ RELIANCE
CUSTOMER _____ S.D. NO. _____
ORDER NO. _____

REV. DESC: UPDATE LOGO AND TITLEBLOCK: LOADED TO BUS		
REV. LTR: -	VERSION: 00	TDR: 000000781086
FILE: \RSN\00026\434	REVISED: 02:35:07 02/01/2013	
MTL: -	BY: MGHPC	

BALDOR

D-C MOTOR CONNECTION DIAGRAM STAB. SHUNT, DUAL VOLTAGE FIELD

SH 1 of 1