

## DISAPPEARING WATER FEATURES - BASINS & VAULTS

Little Giant® heavy-duty disappearing water feature basins are perfect for in-ground installations. These basins are ideal for smaller applications where space is limited. Basins sit flush with the ground, and the sectioned access plates make maintenance a breeze. Cover the basin with a wide variety of rocks or pottery (not included) for a disappearing water effect. Add any container such as a ceramic or stone vase, and a pump to build a stunning disappearing water feature.



SF

### SERIES SPECIFICATIONS

Item No.	Model	Dimensions (in)	Description
566517	DFB36	36" W x 36" L x 10.8" H	Supports up to 2000 lbs
566559	DFB36PP	-	Bulk Priced 566517 w/purchase of 5 units
566558	DFB44	44" W x 44" L x 11" H	Supports up to 3000 lbs
566560	DFB44PP	-	Bulk Priced 566558 w/purchase of 5 units
566410	SF	19" W x 19" L x 22" H	Pump vault for easy pump access

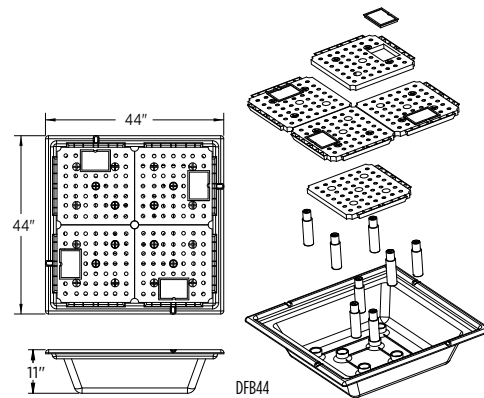
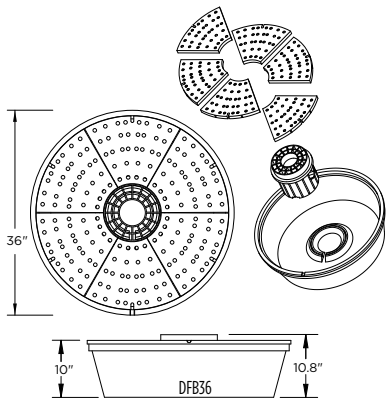

### PARTS

Item No.	Description
166469	6 X Wedge Grates
166468	1 X Basin Column

### PARTS

Item No.	Description
166471	8 X Tubes
166472	1 X Base Plate
166473	4 X Square Grate