

DUTY MASTER ALTERNATING CURRENT MOTORS

SQUIRREL-CAGE INDUCTION
CAST IRON CONSTRUCTION

ENCLOSURE: TOTALLY ENCLOSED
MOUNTING: FOOT

FRAMES 364T-365T

COOLING: FAN COOLED

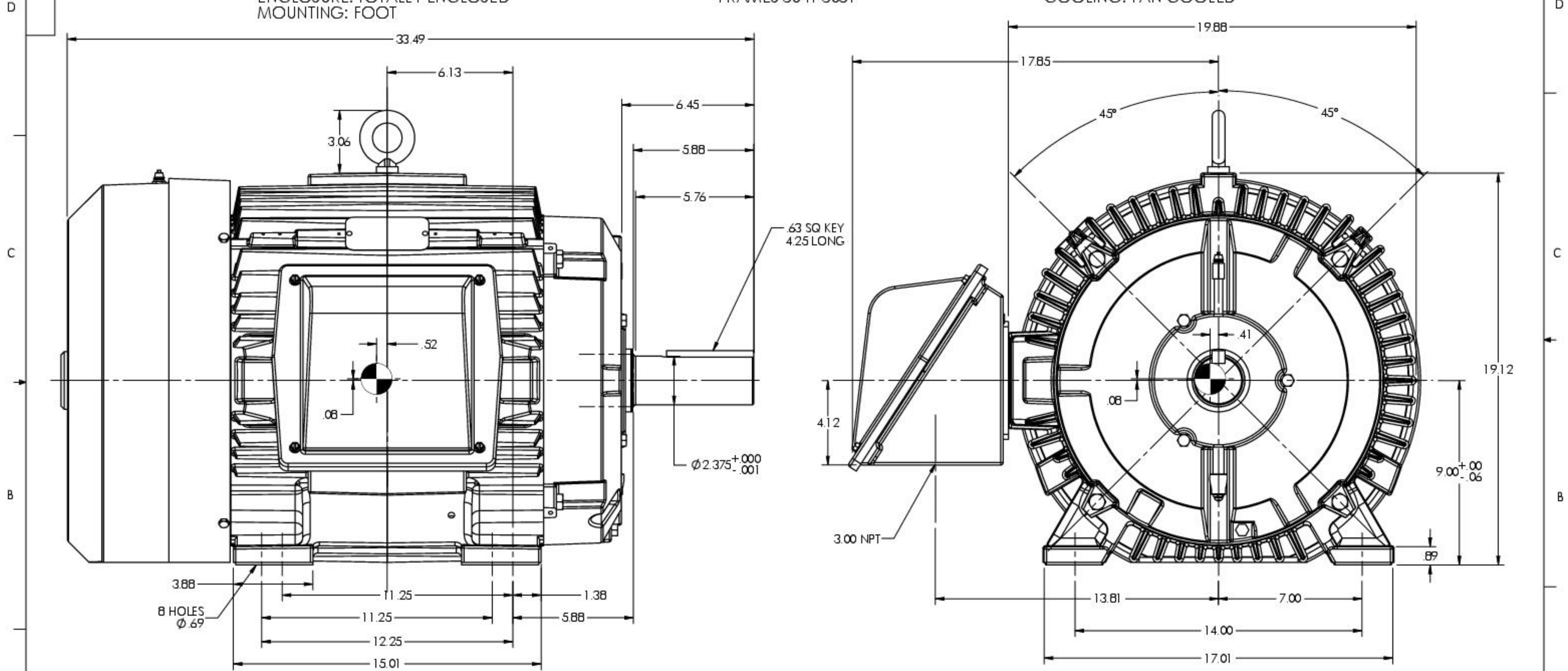

⊕ DENOTES CENTER GRAVITY VARY ± 1.00 INCH

MAXIMUM PERMISSIBLE SHAFT RUNOUT WHEN MEASURED AT
END OF STD. SHAFT EXTENSION IS .002 T.I.R. UP TO AND
INCLUDING 1.625 DIA. AND .003 T.I.R. 1.625 DIA. TO 5 INCH
DIA.

CONDUIT BOXES LOCATED ON OPPOSITE SIDE WHEN F-2, W-1,
W-4, W-5, W-7, OR C-1 MOUNTING IS SPECIFIED

WEIGHT (LBS): 364T = 865
365T = 890

MOTOR WEIGHTS MAY VARY BY 15% DEPENDING UPON RATING.

CUSTOMER IS RESPONSIBLE FOR DETERMINING THAT BALDOR'S PRODUCT WILL PERFORM SUITABLY IN THE INTENDED APPLICATION

REV. DESC: NEW ISSUE			
REV: C	VERSION: 03	REVISED: 01:52:13 06/13/2024	TDR: 000001234622
MODEL NO. 617428-034			REF:
BY: RAGGDM			B

BALDOR

DIM SHEET HOR.364-5T TEFC XT

617428-034