

**BALDOR® • RELIANCE** 

**Product Information Packet**

**ECP4402T-4**

**100HP,3565RPM,3PH,60HZ,405TS,A40060M,TEF**

Part Detail							
Revision:	L	Status:	PRD/A	Change #:		Proprietary:	No
Type:	AC	Elec. Spec:	A40WG0061	CD Diagram:	416820-036	Mfg Plant:	
Mech. Spec:		Layout:	617429-502	Poles:	02	Created Date:	07-15-2013
Base:		Eff. Date:	03-06-2018	Leads:	3#2		

Specs			
Catalog Number:	ECP4402T-4	Heater Indicator:	No Heater
Enclosure:	TEFC	Insulation Class:	F
Frame:	405TS	Inverter Code:	Inverter Ready
Frame Material:	Iron	KVA Code:	F
Output @ Frequency:	100.000 HP @ 60 HZ	Lifting Lugs:	Standard Lifting Lugs
Synchronous Speed @ Frequency:	3600 RPM @ 60 HZ	Motor Lead Quantity/Wire Size:	3 @ 2 AWG
Voltage @ Frequency:	460.0 V @ 60 HZ	Motor Type:	A40060M
XP Class and Group:	None	Mounting Arrangement:	F1
XP Division:	Division II	Power Factor:	90
Agency Approvals:	CSA EEV	Pulley End Bearing Type:	Ball
Auxillary Box:	No Auxillary Box	Pulley Face Code:	Standard
Base Indicator:	Rigid	Shaft Ground Indicator:	No Shaft Grounding
Bearing Grease Type:	Polyrex EM (-20F +300F)	Shaft Rotation:	Reversible
Constant Torque Speed Range:	6-60	Shaft Slinger Indicator:	Shaft Slinger
Current @ Voltage:	110.000 A @ 460.0 V	Speed Code:	Single Speed
Design Code:	B	Motor Standards:	NEMA
Drip Cover:	No Drip Cover	Starting Method:	Direct on line
Duty Rating:	CONT	Thermal Device - Bearing:	NONE (OLD)

<b>Feedback Device:</b>	NO FEEDBACK	<b>Thermal Device - Winding:</b>	None
		<b>XP Temp Code:</b>	T3

Nameplate NP3238									
CAT NO	ECP4402T-4	SPEC NO.	P40G3906						
HP	100	AMPS	110	VOLTS	460	DESIGN	B		
FRAME	405TS	RPM	3565	HZ	60	AMB	40	SF	1.15
D.E. BRG.DATA	6313	O.D.E. BRG.DATA	6313	PH	3	DUTY	CONT	INSUL.CLASS	F
D.E. BRG.	65BC03J30X	TYPE	P	ENCL	TEFC	CODE	F	NEMA NOM EFFICIENCY	95
O.D.E. BRG.	65BC03J30X	POWER FACTOR	90	MAX CORR KVAR	10.0	GUARANTEED EFFICIENCY	94.1		
3/4 LOAD EFF.	95.1	TEMP	= 200						
TEMP CODE	T3	CT HZ	6-60	VT HZ	0-60				
CHP HZ	60-75								
INVERTER-TEMP-CODE	T3								
SER.NO.		MOTOR WEIGHT							

Parts List		
Part Number	Description	Quantity
SA267697	SA P40G3906	1.000 EA
RA254367	RA P40G3906	1.000 EA
NP3238	SS CP XEX SEVERE DUTY MAIN NP	1.000 EA
000692000VD	LABEL WARNING	1.000 EA
000692000FF	N/P	1.000 EA
004824015A	GREASE POLYREX EM	0.544 LB
032018008CK	HHCS 3/8-16X1L PLATED	4.000 EA
032018020EK	HHCS 5/8-11X2-1/2 PLTD.	4.000 EA
032018024CK	HHCS 3/8-16X3 PLTD.	3.000 EA
034000014AB	WSH ID.406 OD.812 TH.065	4.000 EA
034017014AB	LCKW 3/8 STD. PLATED	4.000 EA
034180008DA	KEY 1/4X1/4X1 L (shipping)	1.000 EA
034530052AB	P/NIP 1/8X6-1/2 GALV.	1.000 EA
034530056BB	P/NIP 1/4X7 SCHED 40	1.000 EA
034631002AB	BUSH 1/4 TO 1/8 PLTD.	1.000 EA
083198101A	G400 STD FAN COVER MACHINING	1.000 EA
034692005AA	P PLUG 3/4"BLK.	1.000 EA
089413501A	G400 FIN/MACH FT MTD BRKT 089413500WCA	1.000 EA
410700004F	WSHR	1.000 EA
415045002E	SLGR	1.000 EA
415072001B	CLAMP	1.000 EA
415096002A	CPLG 1/8 HEX TYPE	1.000 EA
702675001D	FAN 250-440	1.000 EA
032018020EK	HHCS 5/8-11X2-1/2 PLTD.	4.000 EA

Parts List (continued)		
Part Number	Description	Quantity
032018024CK	HHCS 3/8-16X3 PLTD.	3.000 EA
034530040AB	P/NIP 1/8X5 GALV.	1.000 EA
034530040BB	P/NIP 1/4X5	1.000 EA
034631002AB	BUSH 1/4 TO 1/8 PLTD.	1.000 EA
089413501A	G400 FIN/MACH FT MTD BRKT 089413500WCA	1.000 EA
415045002E	SLGR	1.000 EA
415096002A	CPLG 1/8 HEX TYPE	1.000 EA
032018010CK	HHCS 3/8-16X1-1/4 PLTD.	4.000 EA
033512008LB	HHTTS 1/4-20X1 PLATED	4.000 EA
034000014AB	WSH ID.406 OD.812 TH.065	4.000 EA
035000001A	ALFTG 1/8" 1610-BL	1.000 EA
035000001A	ALFTG 1/8" 1610-BL	1.000 EA
065776000C	TERBD 320-400	1.000 EA
067053000B	GASK 320-400	1.000 EA
076708000BB	C/B - 360	1.000 EA
076709000A	C/B Cover - 360	1.000 EA
406099000A	PLUG - FAN COVER 320-440	1.000 EA
415000103H	415000103H	1.000 EA
418150003A	GREASE FITTING CAP	1.000 EA
418150003A	GREASE FITTING CAP	1.000 EA
033775004EA	DRSCR #6-1/4 304 S.S.	4.000 EA
034180022GA	KEY 1/2X1/2X2-3/4 L	1.000 EA
MG1025N19	WILKO 778.50 BLUE GREEN - 55 GAL DRUMS	0.375 GA
004824003CBY	WILKO PAINT 060.02 - ACTIVATOR	0.063 GA

421948051	LABEL, MYLAR	1.000 EA
604797045	STD. 400 FRAME SKID	1.000 EA
000613006PU	N/P (RELEASE QTY 10,000) UL CSA LABEL	1.000 EA
LB1449	DIV-2/NEC WARNING LABEL	1.000 EA
035000001G	GREASE RELIEF FITTING, ALEMITE 317400	1.000 EA
035000001G	GREASE RELIEF FITTING, ALEMITE 317400	1.000 EA
032018005DL	1/2-13 X 5/8 SILICON BRONZE HHCS	1.000 EA
412118006A	DRAIN	2.000 EA

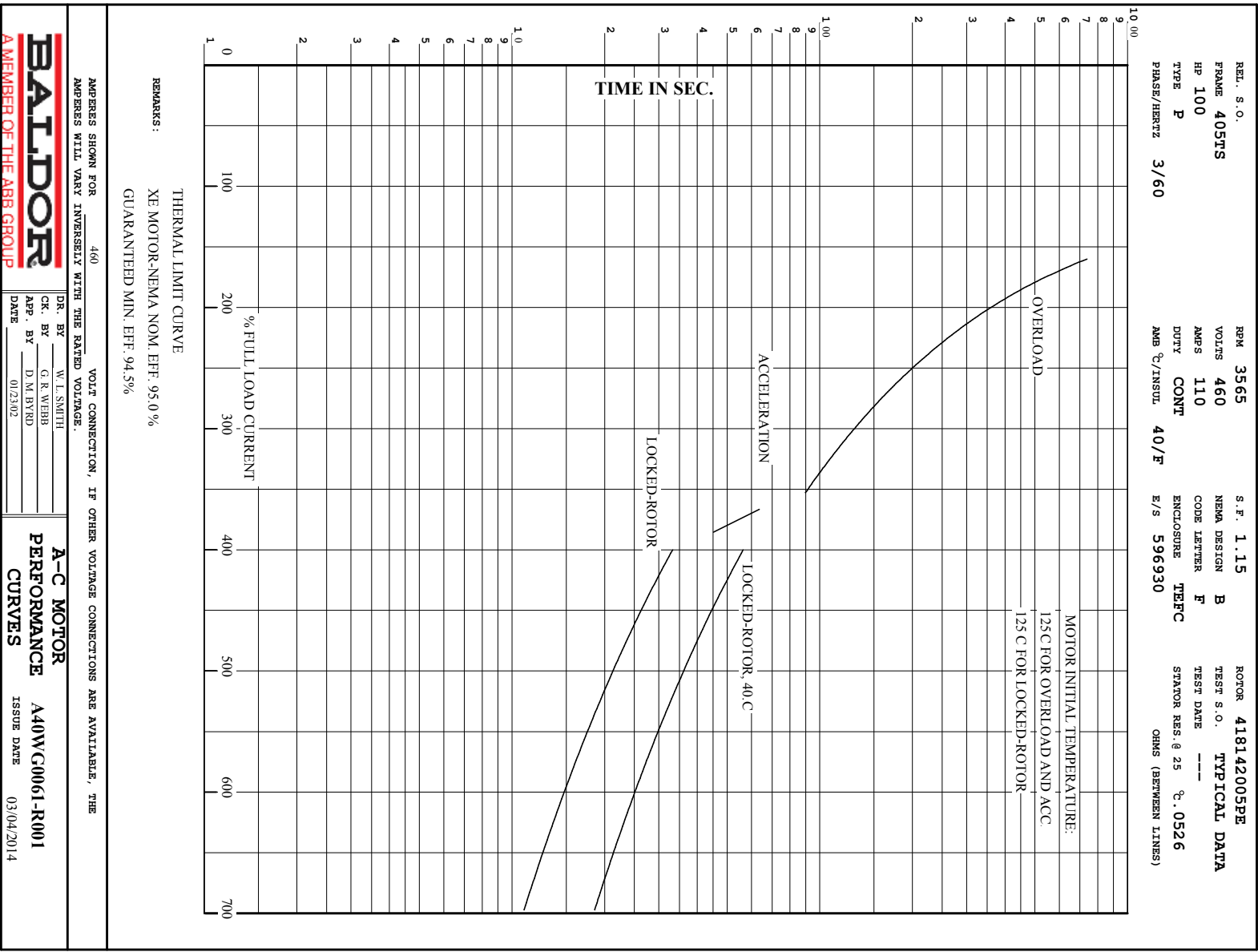



REL. S.O.	FRAME	HP	TYPE	PHASE/HERTZ	RPM	VOLTS
	405TS	100	P	3/60	3565	460
AMPS	DUTY	AMB °C/ INSUL.	S.F.	NEMA DESIGN	CODE LETTER	ENCL.
110	CONT	40/F	1.15	B	F	TEFC
E/S	ROTOR	TEST S.O.	TEST DATE	STATOR RES. @25 °C OHMS (BETWEEN LINES)		
596930	418142005PE	---	---	.0526		

PERFORMANCE

LOAD	HP	AMPERES	RPM	POWER FACTOR %	EFFICIENCY %
NO LOAD	0	25.6	3600	7.57	0
1/4	25.0	36.7	3591	69.7	91.7
2/4	50.0	57.7	3582	85.8	94.6
3/4	75.1	82.7	3572	89.3	95.1
4/4	100	110	3563	89.9	95.0
5/4	125	137	3552	90.2	94.6

SPEED TORQUE

	RPM	TORQUE % FULL LOAD	TORQUE LB.-FT.	AMPERES
LOCKED ROTOR	0	203	299	695
PULL UP	1545	182	269	632
BREAKDOWN	3408	256	377	387
FULL LOAD	3563	100	147	110

AMPERES SHOWN FOR 460. VOLT CONNECTION. IF OTHER VOLTAGE CONNECTIONS ARE AVAILABLE, THE AMPERES WILL VARY INVERSELY WITH THE RATED VOLTAGE

REMARKS: TYPICAL DATA  
 XE MOTOR-NEMA NOM. EFF. 95.0 %  
 GUARANTEED MIN. EFF. 94.5%



DR. BY W. I. SMITH  
 CK. BY G. R. WEBB  
 APP. BY D. M. BYRD  
 DATE 01/23/02

A-C MOTOR  
 PERFORMANCE DATA  
 A40WG0061-R001  
 ISSUE DATE 03/04/20

A MEMBER OF THE ABB GROUP

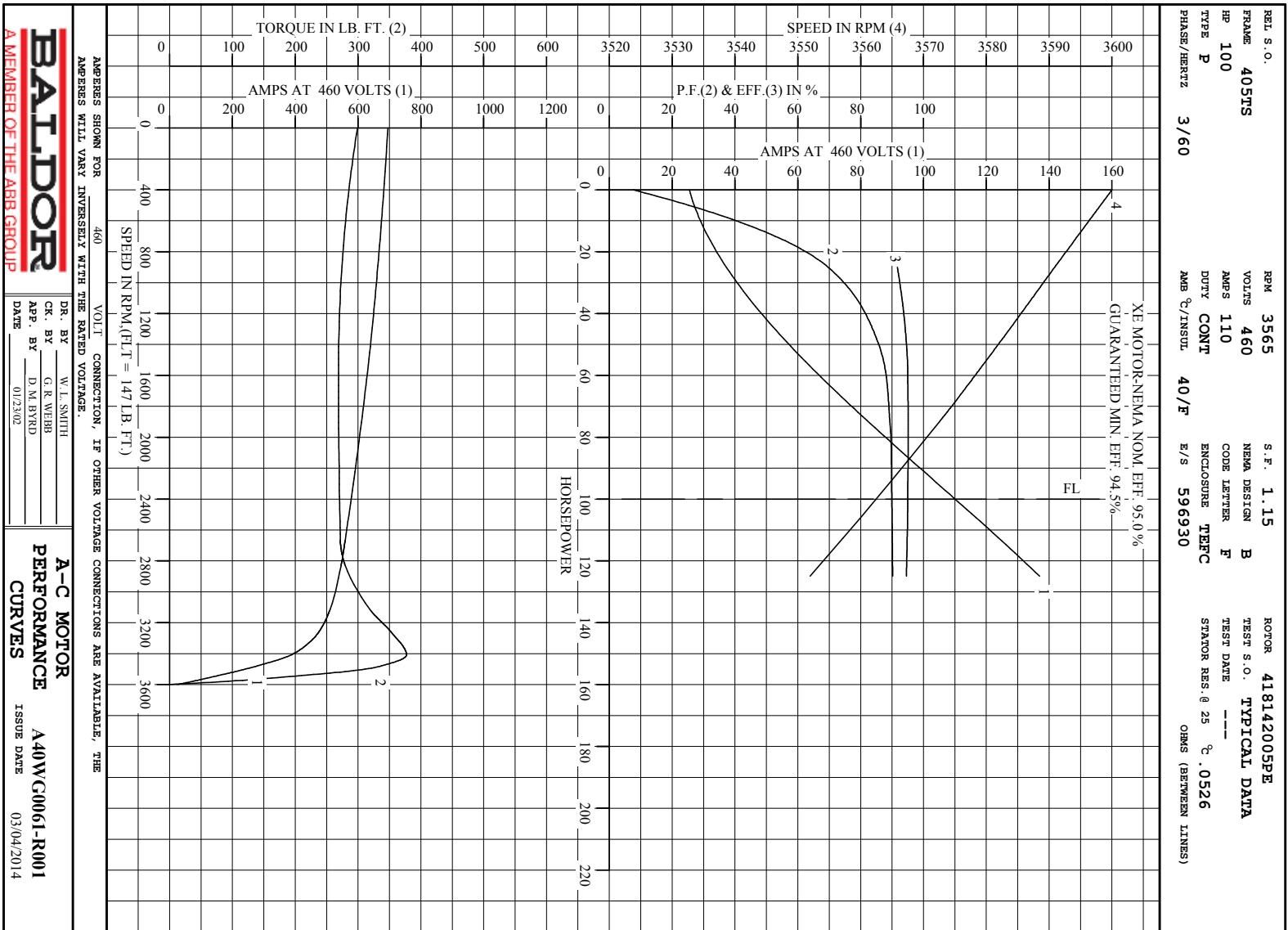

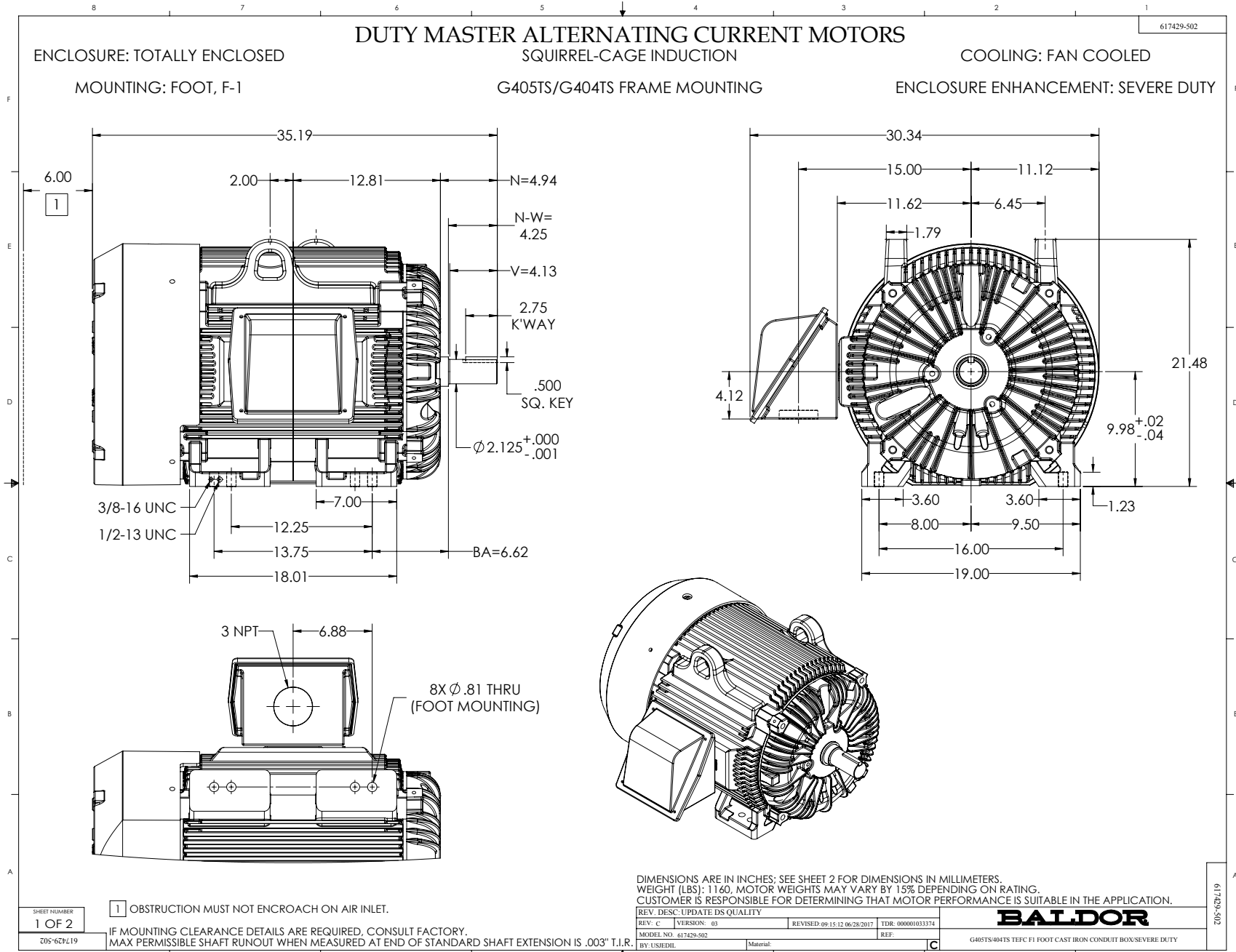

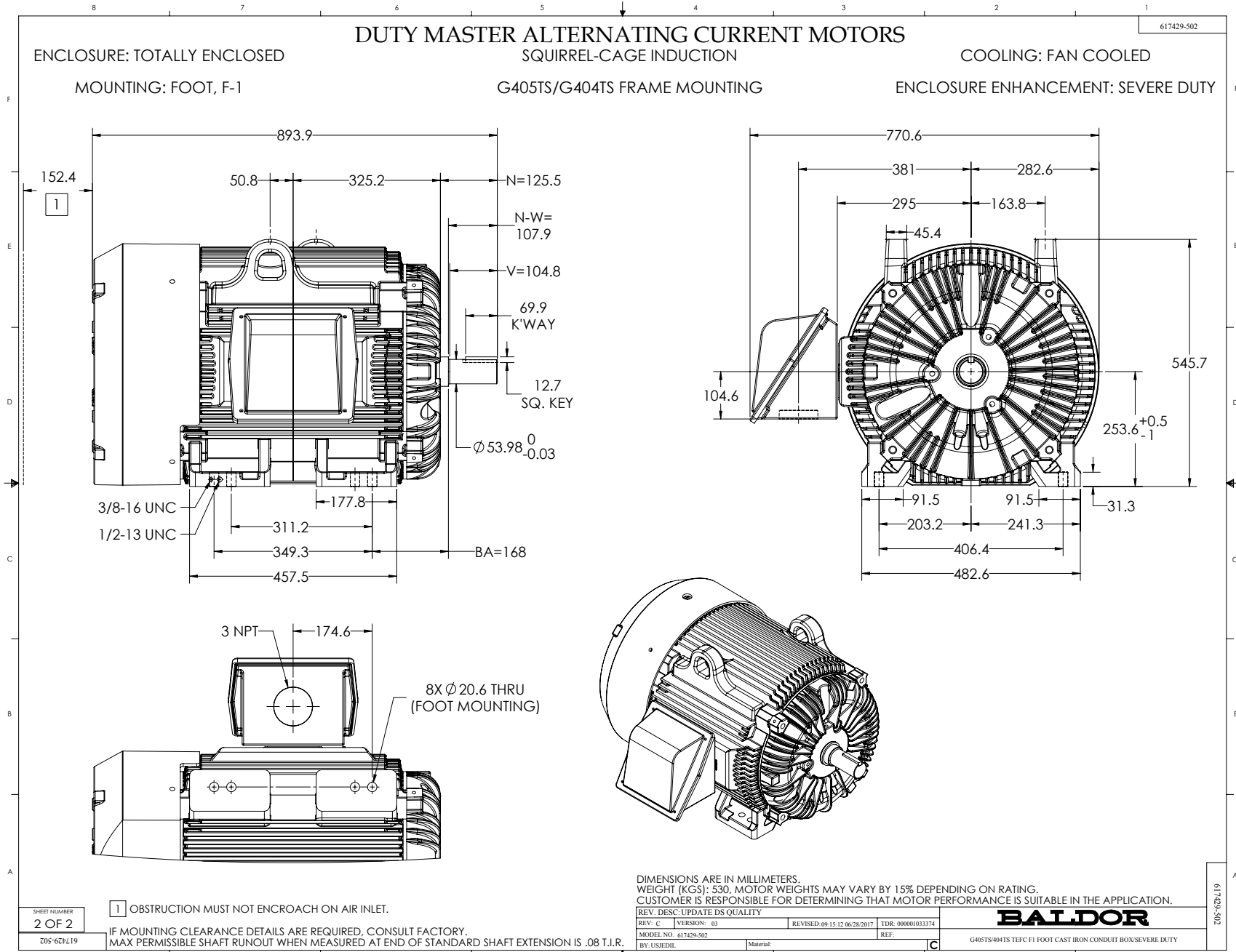

416820-036

A-C MOTOR  
 CONNECTION DIAGRAM  
 STANDARD 3 LEAD CONNECTED

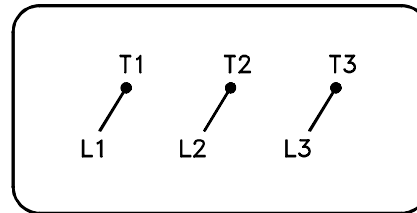

(N.P. 1575-BA)

416820-036

REV. DESC: LOADED TO BUS, C/R 335225		
REV. LTR: -	VERSION: 00	TDR: 000000538207
FILE: \MGA\00000\682	REVISED: 11:54:06 04/30/2010	
MTL: -	BY: RAGRA	

**BALDOR**

CONN DIAG - STANDARD 3 LEAD

SH 1 of 1

Marketing maintained PDF of MN408:

<http://www.baldor.com/support/Literature/Load.ashx/MN408?ManNumber=MN408>

Marketing maintained PDF of MN416:

<http://www.baldor.com/support/Literature/Load.ashx/MN416?ManNumber=MN416>