

**BALDOR® • RELIANCE** 

**Product Information Packet**

**ECP44302T-4**

**300HP,3570RPM,3PH,60HZ,449TS,A44128M,TEF**

Part Detail							
Revision:	Q	Status:	PRD/A	Change #:		Proprietary:	No
Type:	AC	Elec. Spec:	A44WG1242	CD Diagram:	416820-036	Mfg Plant:	
Mech. Spec:		Layout:	617427-006	Poles:	02	Created Date:	08-16-2012
Base:		Eff. Date:	01-11-2018	Leads:	3#2/0 (02 per group)		

Specs			
Catalog Number:	ECP44302T-4	Heater Indicator:	No Heater
Enclosure:	TEFC	Insulation Class:	F
Frame:	449TS	Inverter Code:	Not Inverter
Frame Material:	Iron	KVA Code:	G
Output @ Frequency:	300.000 HP @ 60 HZ	Lifting Lugs:	No Lifting Lugs
Synchronous Speed @ Frequency:	3600 RPM @ 60 HZ	Motor Lead Quantity/Wire Size:	6 @ 2/0 AWG
Voltage @ Frequency:	460.0 V @ 60 HZ	Motor Type:	A44128M
XP Class and Group:	None	Mounting Arrangement:	F1
XP Division:	Division II	Power Factor:	91
Agency Approvals:	CSA EEV	Pulley End Bearing Type:	Ball
Auxillary Box:	No Auxillary Box	Pulley Face Code:	Standard
Base Indicator:	Rigid	Shaft Ground Indicator:	No Shaft Grounding
Bearing Grease Type:	Polyrex EM (-20F +300F)	Shaft Rotation:	Reversible
Constant Torque Speed Range:	30-60	Shaft Slinger Indicator:	No Slinger
Current @ Voltage:	318.000 A @ 460.0 V	Speed Code:	Single Speed
Design Code:	B	Motor Standards:	NEMA
Drip Cover:	No Drip Cover	Starting Method:	Direct on line
Duty Rating:	CONT	Thermal Device - Bearing:	NONE (OLD)

<b>Feedback Device:</b>	NO FEEDBACK	<b>Thermal Device - Winding:</b>	None
		<b>XP Temp Code:</b>	T2C

Nameplate NP3238									
CAT NO	ECP44302T-4	SPEC NO.	P44G3953						
HP	300	AMPS	318	VOLTS	460	DESIGN	B		
FRAME	449TS	RPM	3570	HZ	60	AMB	40	SF	1.15
D.E. BRG.DATA	6313	O.D.E. BRG.DATA	6313	PH	3	DUTY	CONT	INSUL.CLASS	F
D.E. BRG.	65BC03J30X	TYPE	P	ENCL	TEFC	CODE	G	NEMA NOM EFFICIENCY	96.2
O.D.E. BRG.	65BC03J30X	POWER FACTOR	91	MAX CORR KVAR	30.0	GUARANTEED EFFICIENCY	95.8		
3/4 LOAD EFF.	96.5	TEMP	= 230						
TEMP CODE	T2C	CT HZ	30-60	VT HZ	0-60				
CHP HZ	60-75								
INVERTER-TEMP-CODE	T2C								
SER.NO.		MOTOR WEIGHT							

Parts List		
Part Number	Description	Quantity
SA249723	SA P44G3953	1.000 EA
RA236583	RA P44G3953	1.000 EA
NP3238	SS CP XEX SEVERE DUTY MAIN NP	1.000 EA
000692000FF	N/P	1.000 EA
000692000VD	LABEL WARNING	1.000 EA
004824015A	GREASE POLYREX EM	0.544 LB
032018008CK	HHCS 3/8-16X1L PLATED	4.000 EA
032018012BK	HHCS 5/16-16X1-1/2PLATED	4.000 EA
032018020FK	HHCS 3/4-10X2-1/2 PLTD.	4.000 EA
032018028CK	HHCS 3/8-16X3-1/2 PLTD.	3.000 EA
034180014DA	KEY 1/4X1/4X1-3/4 L	1.000 EA
034530072AB	P/NIP 1/8X9"L Threaded both ends	1.000 EA
034530072BB	PIPE NIPPLE,DE - 440-BS	1.000 EA
034631002AB	BUSH 1/4 TO 1/8 PLTD.	1.000 EA
035000001G	GREASE RELIEF FITTING, ALEMITE 317400	1.000 EA
034690005AB	PPLG 3/4 PLATED	1.000 EA
083199082RA	G28 SHORT FAN COVER W/BAFFLE ASSEMBLY	1.000 EA
089490097A	BRKT 089490102WCA	1.000 EA
410700004F	WSHR	1.000 EA
415072001B	CLAMP	1.000 EA
415096002A	CPLG 1/8 HEX TYPE	1.000 EA
702676001D	FAN 250-440	1.000 EA
032018004BK	HHCS 5/16-18X1/2 PLATED	3.000 EA
032018006BK	HHCS 5/16-18X3/4 PLATED	3.000 EA

Parts List (continued)		
Part Number	Description	Quantity
032018020FK	HHCS 3/4-10X2-1/2 PLTD.	4.000 EA
032018022CK	HHCS 3/8-16X2-3/4 PLTD	3.000 EA
034000013AB	WSHR 5/16" PLATED-440	3.000 EA
034017013AB	LCKW 5/16 STD. PLATED	3.000 EA
034530072AB	P/NIP 1/8X9"L Threaded both ends	1.000 EA
034530072BB	PIPE NIPPLE,DE - 440-BS	1.000 EA
034631002AB	BUSH 1/4 TO 1/8 PLTD.	1.000 EA
035000001G	GREASE RELIEF FITTING, ALEMITE 317400	1.000 EA
089490097A	BRKT 089490102WCA	1.000 EA
415915007K	GASK, 26" LAC	1.000 EA
415045002E	SLGR	1.000 EA
415096002A	CPLG 1/8 HEX TYPE	1.000 EA
702623022A	G28 AIR DEFLECTOR DRIVE END -- PLASTIC	1.000 EA
702623012A	THERMAL BARRIER, G28	1.000 EA
032018008BK	HHCS 5/16-18X1L PLATED	4.000 EA
032018008DK	HHCS 1/2-13X1 PLATED	4.000 EA
033512004LB	HHTTS 1/4-20X1/2 PLTD.	1.000 EA
035000001A	ALFTG 1/8" 1610-BL	1.000 EA
035000001A	ALFTG 1/8" 1610-BL	1.000 EA
067053014A	GASK 440	1.000 EA
076870000B	+CBCST BLKT - 440	1.000 EA
076871000A	+CBOX CVR BLKT - 449	1.000 EA
406056007A	GASKET, 440	1.000 EA
406099000A	PLUG - FAN COVER 320-440	1.000 EA

Product Information Packet: ECP44302T-4 - 300HP,3570RPM,3PH,60HZ,449TS,A44128M,TEF

415000103D	T/LUG #4AWG-1/0AWG W/HOLE FOR .250 BOLT	1.000 EA
418150003A	GREASE FITTING CAP	1.000 EA
418150003A	GREASE FITTING CAP	1.000 EA
033775004EA	DRSCR #6-1/4 304 S.S.	2.000 EA
034180024HA	KEY 5/8X5/8X3 L	1.000 EA
MG1025N19	WILKO 778.50 BLUE GREEN - 55 GAL DRUMS	0.375 GA
004824003CBY	WILKO PAINT 060.02 - ACTIVATOR	0.094 GA
L482401016	SPRAY AC-29-7S	0.019 GA
421948051	LABEL, MYLAR	1.000 EA
PK5005A01	WOOD BASE 449 60 X 41-1/2 BLT 25 X 18	1.000 EA
000613006PU	N/P (RELEASE QTY 10,000) UL CSA LABEL	1.000 EA
LB1449	DIV-2/NEC WARNING LABEL	1.000 EA
412118006A	DRAIN	2.000 EA

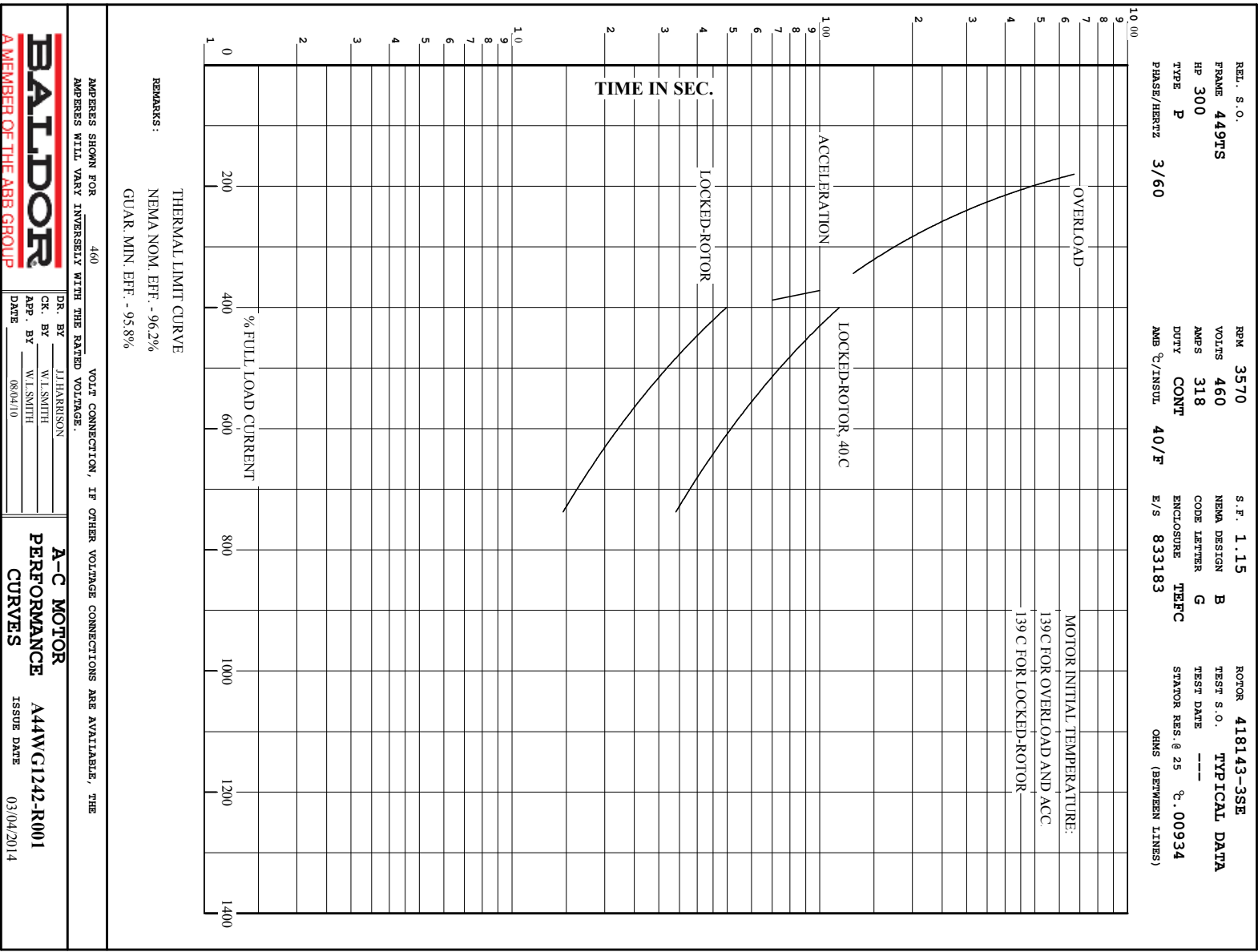



REL. S.O.	FRAME	HP	TYPE	PHASE/HERTZ	RPM	VOLTS
	449TS	300	P	3/60	3570	460
AMPS	DUTY	AMB °C/INSUL.	S.F.	NEMA DESIGN	CODE LETTER	ENCL.
318	CONT	40/F	1.15	B	G	TEFC
E/S	ROTOR	TEST S.O.	TEST DATE	STATOR RES. @25 °C OHMS (BETWEEN LINES)		
833183	418143-3SE	---	---	---		.00934

PERFORMANCE

LOAD	HP	AMPERES	RPM	POWER FACTOR %	EFFICIENCY %
NO LOAD	0	59.3	3600	6.34	0
1/4	75.0	109	3593	68.4	94.3
2/4	150	172	3586	84.8	96.3
3/4	225	244	3578	89.4	96.5
4/4	300	321	3571	90.8	96.4
5/4	375	402	3562	91.0	96.0
SPEED TORQUE					
		RPM	TORQUE % FULL LOAD	TORQUE LB.-FT.	AMPERES
LOCKED ROTOR		0	159	703	2149
PULL UP		1620	142	627	1977
BREAKDOWN		3464	274	1208	1062
FULL LOAD		3571	100	441	321

AMPERES SHOWN FOR 460. VOLT CONNECTION. IF OTHER VOLTAGE CONNECTIONS ARE AVAILABLE, THE AMPERES WILL VARY INVERSELY WITH THE RATED VOLTAGE

REMARKS: TYPICAL DATA  
 NEMA NOM. EFF. - 96.2%  
 GUAR. MIN. EFF. - 95.8%



DR. BY J.J. HARRISON  
 CK. BY W.L. SMITH  
 APP. BY W.L. SMITH  
 DATE 08/04/10

A-C MOTOR PERFORMANCE DATA  
 A44WG1242-R001  
 ISSUE DATE 03/04/20

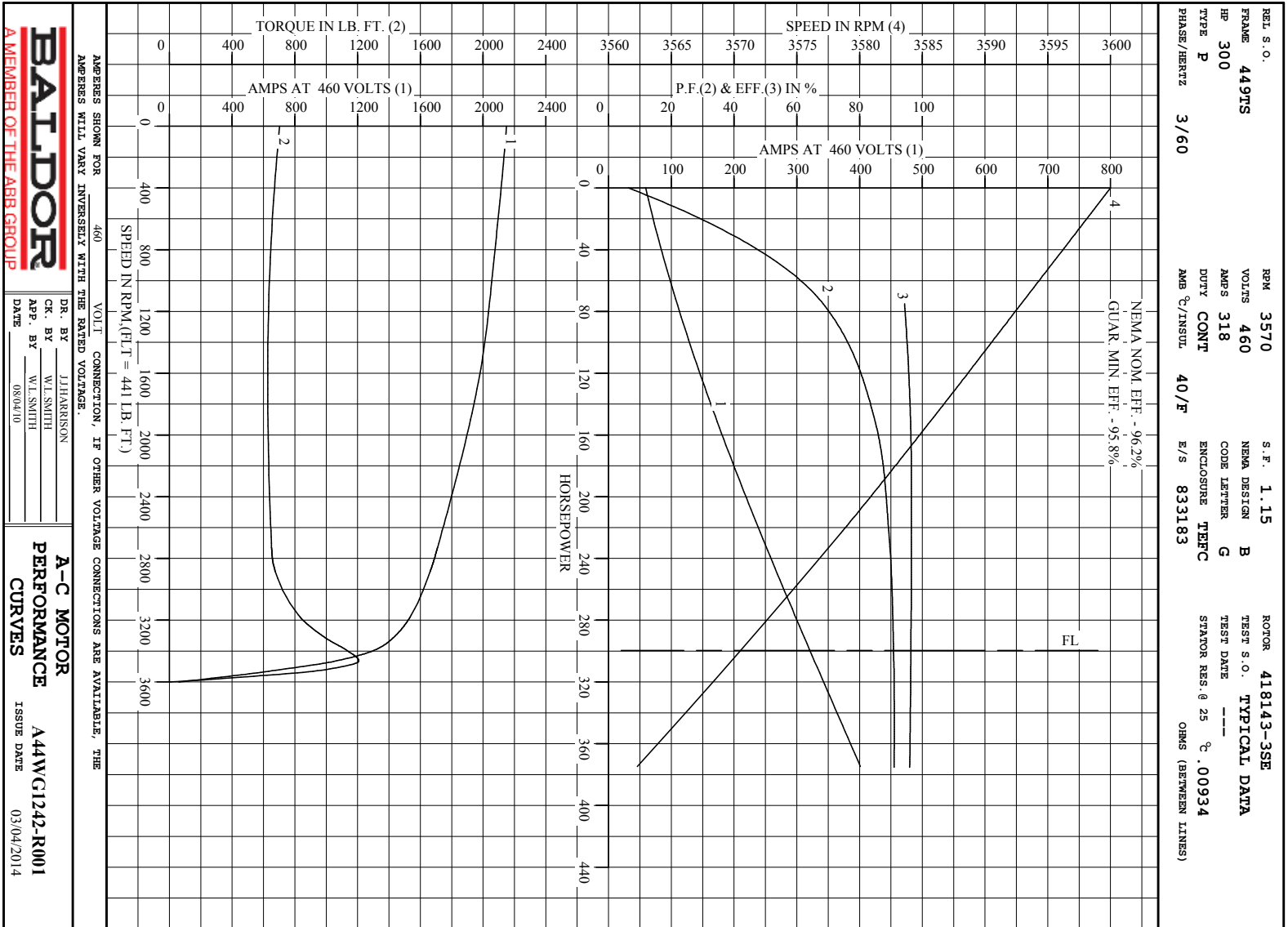

**BALDOR**  
 A MEMBER OF THE ABB GROUP

DR. BY J. HARRISON  
 CK. BY W. SMITH  
 App. BY W. SMITH  
 DATE 08/04/10

**A-C MOTOR**  
**PERFORMANCE**  
**CURVES**

A44WC1242-R001  
 ISSUE DATE 03/04/2014

Printed on 3/4/14 7:46 @ fagsun

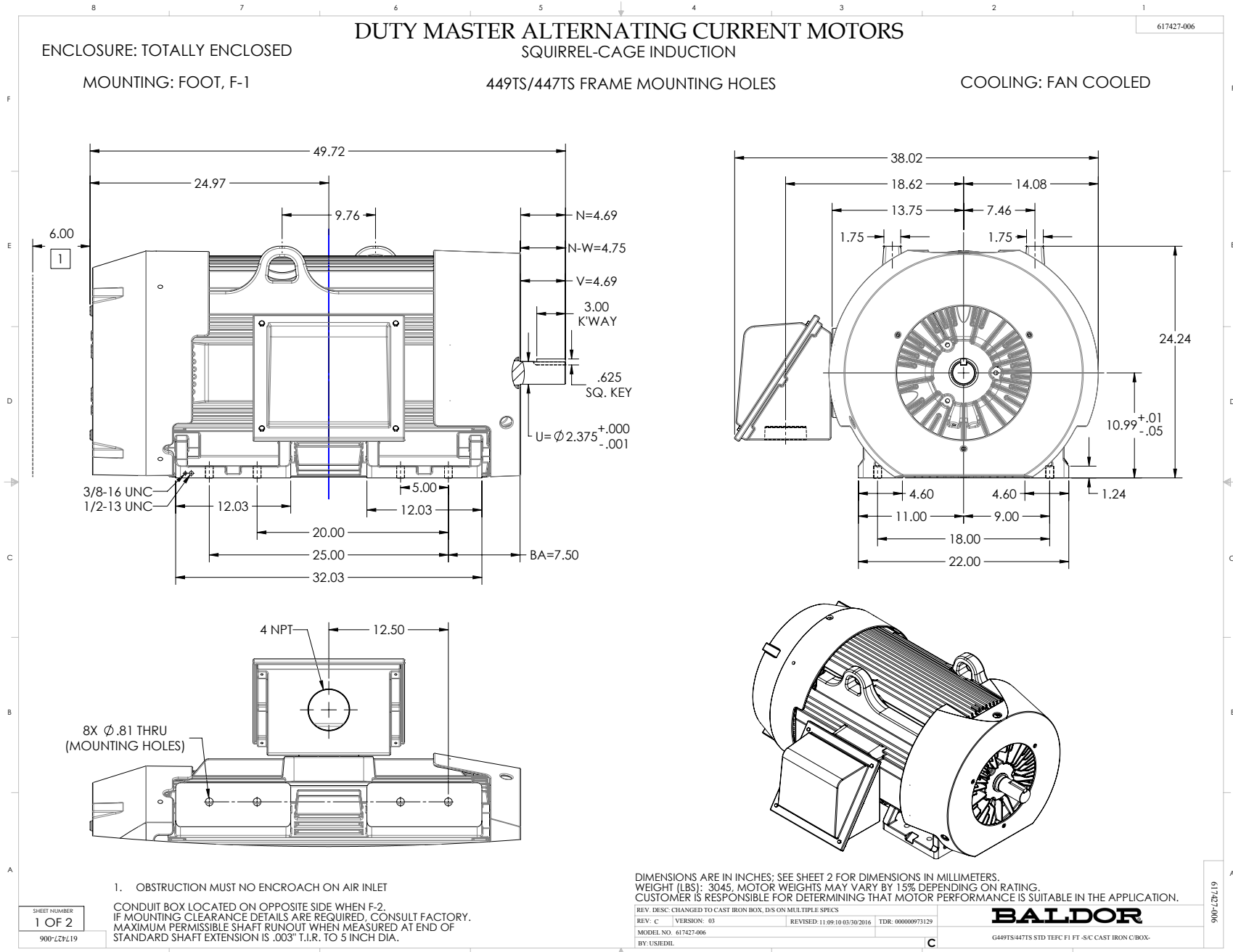

**DUTY MASTER ALTERNATING CURRENT MOTORS**  
SQUIRREL-CAGE INDUCTION

617427-006

ENCLOSURE: TOTALLY ENCLOSED

MOUNTING: FOOT, F-1

449TS/447TS FRAME MOUNTING HOLES

COOLING: FAN COOLED

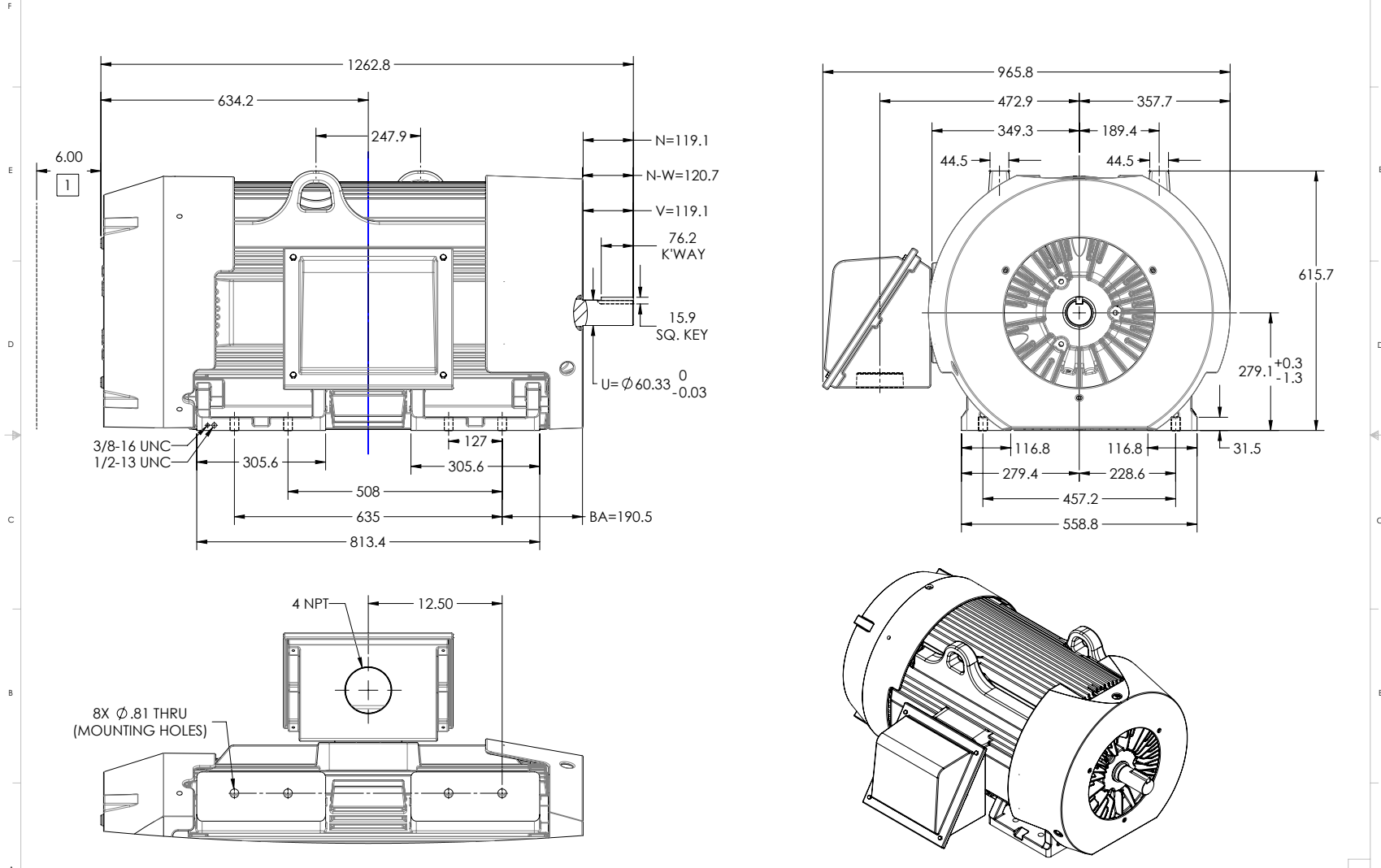

1. OBSTRUCTION MUST NO ENCROACH ON AIR INLET

CONDUIT BOX LOCATED ON OPPOSITE SIDE WHEN F-2.  
IF MOUNTING CLEARANCE DETAILS ARE REQUIRED, CONSULT FACTORY.  
MAXIMUM PERMISSIBLE SHAFT RUNOUT WHEN MEASURED AT END OF  
STANDARD SHAFT EXTENSION IS .08 MM T.I.R. TO 127 MM DIA.

DIMENSIONS ARE IN MILLIMETERS; SEE SHEET 1 FOR DIMENSIONS IN INCHES.  
WEIGHT (KGS): 1380. MOTOR WEIGHTS MAY VARY BY 15% DEPENDING ON RATING.  
CUSTOMER IS RESPONSIBLE FOR DETERMINING THAT MOTOR PERFORMANCE IS SUITABLE IN THE APPLICATION.

REV. DESC: CHANGED TO CAST IRON BOX, DS ON MULTIPLE SPECS	VERSION: 03	REVISED: 11-09-10 03:30/2016	TDR: 00000973129
MODEL NO. 617427-006	BY: USJEDL		

**BALDOR**

G449TS/447TS STD TEF C F1 FT -S/C CAST IRON C/BOX-

SHEET NUMBER  
**2 OF 2**  
900-27-119

617427-006

416820-036

A-C MOTOR  
 CONNECTION DIAGRAM  
 STANDARD 3 LEAD CONNECTED

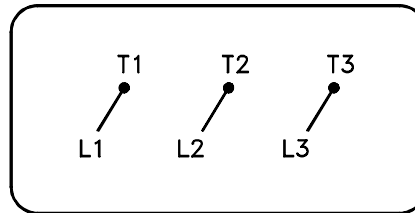

(N.P. 1575-BA)

416820-036

REV. DESC: LOADED TO BUS, C/R 335225		
REV. LTR: -	VERSION: 00	TDR: 000000538207
FILE: \MGA\00000\682	REVISED: 11:54:06 04/30/2010	
MTL: -	BY: RAGRA	

**BALDOR**

CONN DIAG - STANDARD 3 LEAD

SH 1 of 1

Marketing maintained PDF of MN408:

<http://www.baldor.com/support/Literature/Load.ashx/MN408?ManNumber=MN408>

Marketing maintained PDF of MN416:

<http://www.baldor.com/support/Literature/Load.ashx/MN416?ManNumber=MN416>