

**BALDOR® • RELIANCE** 

**Product Information Packet**

**ECTM3774T**

**10 AIR OVERHP,1760RPM,3PH,60HZ,213T,0748**

Part Detail							
Revision:	H	Status:	PRD/A	Change #:		Proprietary:	No
Type:	AC	Elec. Spec:	07WGY179	CD Diagram:	CD0005	Mfg Plant:	
Mech. Spec:	07N391	Layout:	07LYN391	Poles:	04	Created Date:	08-14-2015
Base:	RG	Eff. Date:	04-09-2018	Leads:	9#14		

Specs			
Catalog Number:	ECTM3774T	Heater Indicator:	No Heater
Enclosure:	TEAO	Insulation Class:	F
Frame:	213T	Inverter Code:	Inverter Ready
Frame Material:	Iron	KVA Code:	H
Output @ Frequency:	10.000 HP @ 60 HZ	Lifting Lugs:	Vertical Lifting Lugs
Synchronous Speed @ Frequency:	1800 RPM @ 60 HZ	Locked Bearing Indicator:	Locked Bearing
Voltage @ Frequency:	208.0 V @ 60 HZ	Motor Lead Quantity/Wire Size:	9 @ 14 AWG
	460.0 V @ 60 HZ	Motor Lead Exit:	Ko Box
	230.0 V @ 60 HZ	Motor Lead Termination:	Flying Leads
XP Class and Group:	None	Motor Type:	0748M
XP Division:	Not Applicable	Mounting Arrangement:	F1
Agency Approvals:	CSA	Power Factor:	83
	CSA EEV	Product Family:	Chemical Processing (Not DC)
	UR	Pulley End Bearing Type:	Sealed Bearing
Auxillary Box:	No Auxillary Box	Pulley Face Code:	Standard
Auxillary Box Lead Termination:	None	Pulley Shaft Indicator:	Tapped & Key
Base Indicator:	Rigid	Rodent Screen:	None
Bearing Grease Type:	Polyrex EM (-20F +300F)	Shaft Extension Location:	Pulley End

<b>Blower:</b>	None	<b>Shaft Ground Indicator:</b>	No Shaft Grounding
<b>Current @ Voltage:</b>	26.500 A @ 208.0 V	<b>Shaft Rotation:</b>	Reversible
	24.400 A @ 230.0 V	<b>Shaft Slinger Indicator:</b>	Shaft Slinger
	12.200 A @ 460.0 V	<b>Speed Code:</b>	Single Speed
<b>Design Code:</b>	B	<b>Motor Standards:</b>	NEMA
<b>Drip Cover:</b>	No Drip Cover	<b>Starting Method:</b>	Direct on line
<b>Duty Rating:</b>	CONT	<b>Thermal Device - Bearing:</b>	NONE (OLD)
<b>Electrically Isolated Bearing:</b>	Not Electrically Isolated	<b>Thermal Device - Winding:</b>	None
<b>Feedback Device:</b>	NO FEEDBACK	<b>Vibration Sensor Indicator:</b>	No Vibration Sensor
<b>Front Face Code:</b>	Standard	<b>Winding Thermal 1:</b>	None
<b>Front Shaft Indicator:</b>	None	<b>Winding Thermal 2:</b>	None

<b>Nameplate NP1260E</b>											
<b>CAT.NO.</b>	ECTM3774T										
<b>SPEC.</b>	07N391Y179G1										
<b>HP</b>	10 AIR OVER										
<b>VOLTS</b>	208-230/460										
<b>AMP</b>	26.5-24.4/12.2										
<b>RPM</b>	1760										
<b>FRAME</b>	213T					<b>HZ</b>	60		<b>PH</b>	3	
<b>SER.F.</b>	1.15			<b>CODE</b>	H	<b>DES</b>	B		<b>CL</b>	F	
<b>NEMA-NOM-EFF</b>	91.7			<b>PF</b>	83						
<b>RATING</b>	40C AMB-CONT										
<b>CC</b>									<b>USABLE AT 208V</b>	26.5	
<b>DE</b>	6307			<b>ODE</b>	6206						
<b>ENCL</b>	TEAO			<b>SN</b>							
	1700 FPM 170 CFM										

Parts List		
Part Number	Description	Quantity
SA306957	SA 07N391Y179G1	1.000 EA
RA294232	RA 07N391Y179G1	1.000 EA
HW3201A05	3/8-16 EYEBOLT	1.000 EA
HA7205	"L" SHAPE LIFTING LUG FOR 37,39 & 40 FRA	2.000 EA
09CB1002A26G	KOBX W/1.00 NPT LD HL .25-20 TAP FOR LID	1.000 EA
RM1017	LEAD SEPERATOR GASKET MODEL 307 1/8" THK	1.000 EA
19XW2520A16	SCREW,1/4-20X1 TAPTITE-II OR ROLOC 91	2.000 EA
11XW1032G06	10-32 X .38, TAPTITE II, HEX WSHR SLTD U	1.000 EA
HW3001B01	BRASS CUP WASHER, FOR #10 SCREW	1.000 EA
HA4044A00	PLUG,PIPE 1/8 NPT PLASTIC SQUARE HEAD	2.000 EA
10XN2520S06	1/4 20X3/8 HX HD CAP S.S.	1.000 EA
WD1000B16	T&B CX70TN TERMINAL	1.000 EA
10XN2520A28	1/4-20X 1 3/4 HEX HD	4.000 EA
37EP1100D74G	FRONT TENV 37M 206 BRG COOLING TOWER W/O	1.000 EA
HA4054	SHORT T-DRAIN FITTING, .125" N.P.T.	1.000 EA
HA4044A00	PLUG,PIPE 1/8 NPT PLASTIC SQUARE HEAD	2.000 EA
51XN1032A22	10-32 X 1 3/8 HX WS SL SR	2.000 EA
HW5100A06	W2420-025 WVY WSHR (WB)	1.000 EA
37EP1101C77G	PULLEY 213-5T ENCL 307 BRG COOLING TOWER	1.000 EA
HW4600B51	SEAL 1.375 X 2.125 X 0.313 SINGLE LIP DB	1.000 EA
HA4054	SHORT T-DRAIN FITTING, .125" N.P.T.	1.000 EA
HA4044A00	PLUG,PIPE 1/8 NPT PLASTIC SQUARE HEAD	2.000 EA
XY3118A12	5/16-18 HEX NUT DIRECTIONAL SERRATION	4.000 EA
12CB1503G	CONDUIT BOX CAST. (GRAY)	1.000 EA

Parts List (continued)		
Part Number	Description	Quantity
12GS1002	GASKET, CONDUIT BOX LID, NEOP	1.000 EA
10XN2520A24	1/4-20X 1 1/2 HEX HD X	2.000 EA
HW1001A25	LOCKWASHER 1/4, ZINC PLT .493 OD, .255 I	2.000 EA
HW2501F21	KEY, 5/16 SQ X 2.375	1.000 EA
HA7000A02	KEY RETAINER RING, 1 1/8 DIA, 1 3/8 DIA	1.000 EA
HW4600B33	V-RING SLINGER 1.375 X 1.890 X .35 VITON	1.000 EA
HW4600G52	DOME SLINGER, 5.438 OD X 1.370/1.320 ID	1.000 EA
MJ5001A27	32220KN GRAY SEALER *MIN BUY 4 QTS=1GAL	0.001 QT
MJ5001A02	732 CL SEALANT 3 OZ DIXIE BEARING 289100	1.000 EA
85XU0407S04	4X1/4 U DRIVE PIN STAINLESS	2.000 EA
HA5027A04	HA4054 T-DRAIN X2 BAGGED	1.000 EA
LB1115N	LABEL,LIFTING DEVICE (ON ROLLS)	1.000 EA
LB1182	WARNING LABEL FOR MOTORS WITH EYENUTS	1.000 EA
MJ1000A02	GREASE, POLYREX EM EXXON (USe 4824-15A)	0.050 LB
HA3104A28	THRUBOLT .31-18 X 13.062	4.000 EA
MG1025G29	WILKOFASST, 789.229, DARK CHARCOAL GRAY	0.036 GA
LC0005E01	CONN.DIA./WARNING LABEL (LC0005/LB1119N)	1.000 EA
NP1260E	SS CP SUPER-E UL CSA CC	1.000 EA
07PA1011	PKG GRP, 07 CAST IRON PK1181	1.000 EA
10XL3808A28	3/8 X 1 3/4" LAG SCREW	2.000 EA
MN416A01	TAG-INSTAL-MAINT no wire (1200/bx) 5/18	1.000 EA
LB1417	LABEL CARTON 6X4 PERFORATED BLANK ROLLS	1.000 EA

**AC Induction Motor Performance Data**

Record # 35568 - Typical performance - not guaranteed values

<b>Winding:</b> 07WGY179-R006	<b>Type:</b> 0748M	<b>Enclosure:</b> TEAO
-------------------------------	--------------------	------------------------

Nameplate Data				460 V, 60 Hz: High Voltage Connection	
Rated Output (HP)	10 AIR OVER			Full Load Torque	29.8 LB-FT
Volts	208-230/460			Start Configuration	direct on line
Full Load Amps	26.5-24.4/12.2			Breakdown Torque	80.9 LB-FT
R.P.M.	1760			Pull-up Torque	40.2 LB-FT
Hz	60	Phase	3	Locked-rotor Torque	52.6 LB-FT
NEMA Design Code	B	KVA Code	H	Starting Current	81 A
Service Factor (S.F.)	1.15			No-load Current	4.44 A
NEMA Nom. Eff.	91.7	Power Factor	83	Line-line Res. @ 25°C	1.08 Ω
Rating - Duty	40C AMB-CONT			Temp. Rise @ Rated Load	64°C
S.F. Amps				Temp. Rise @ S.F. Load	80°C
				Locked-rotor Power Factor	35
				Rotor inertia	1.18 LB-FT <sup>2</sup>

**Load Characteristics 460 V, 60 Hz, 10 HP**

% of Rated Load	25	50	75	100	125	150	S.F.
Power Factor	50	71	80	83	85	85	84
Efficiency	90.4	92.5	92.9	92.4	91	89.1	91.6
Speed	1791	1782	1774	1763	1751	1737	1756
Line amperes	5.24	7.1	9.42	12.2	15.2	18.7	14

Performance Graph at 460V, 60Hz, 10.0HP Typical performance - Not guaranteed values

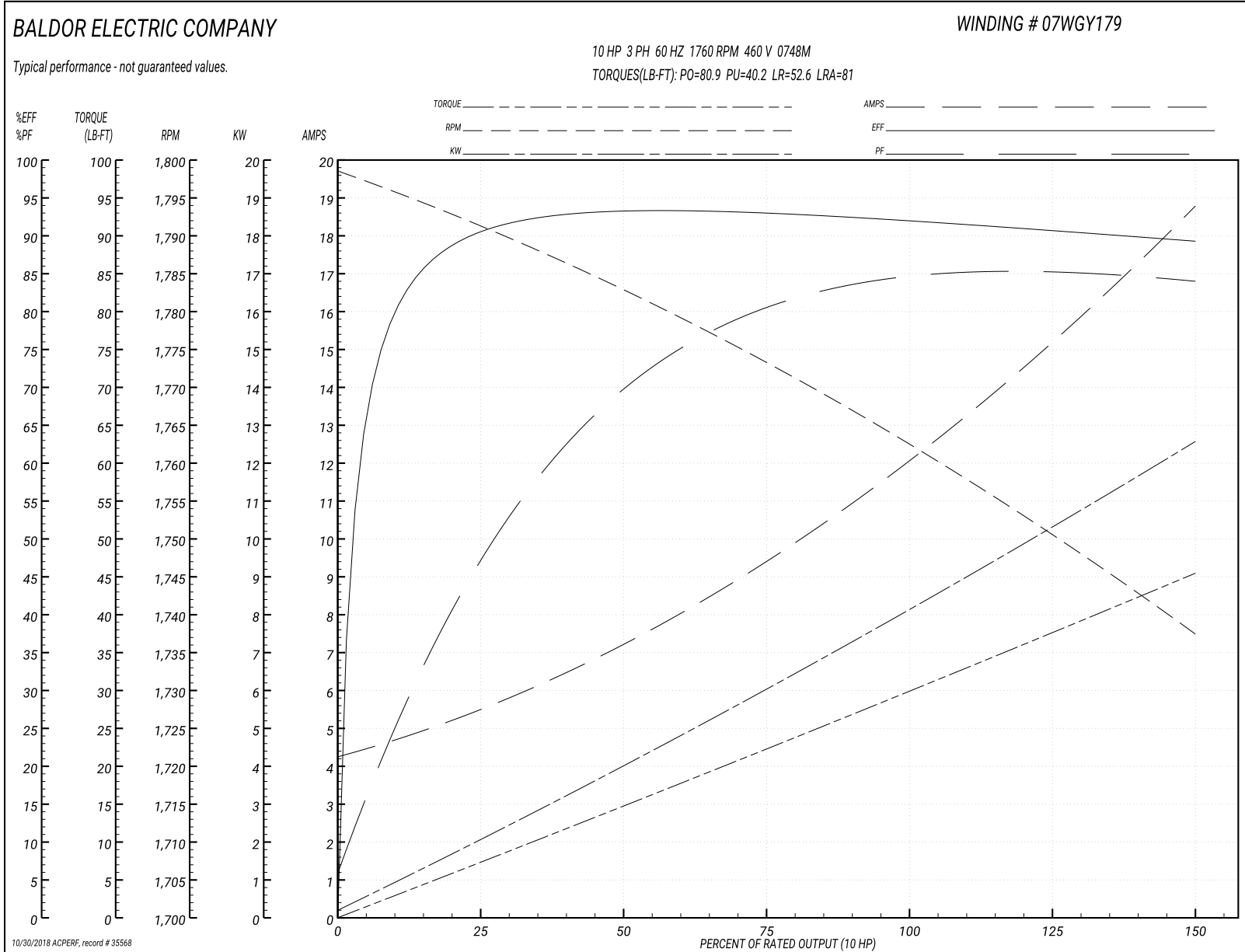



07LYN391

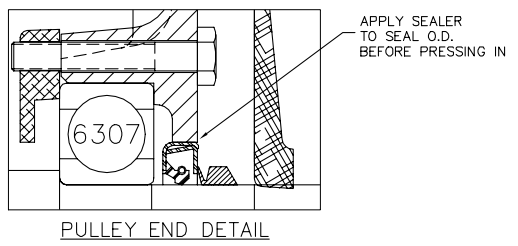
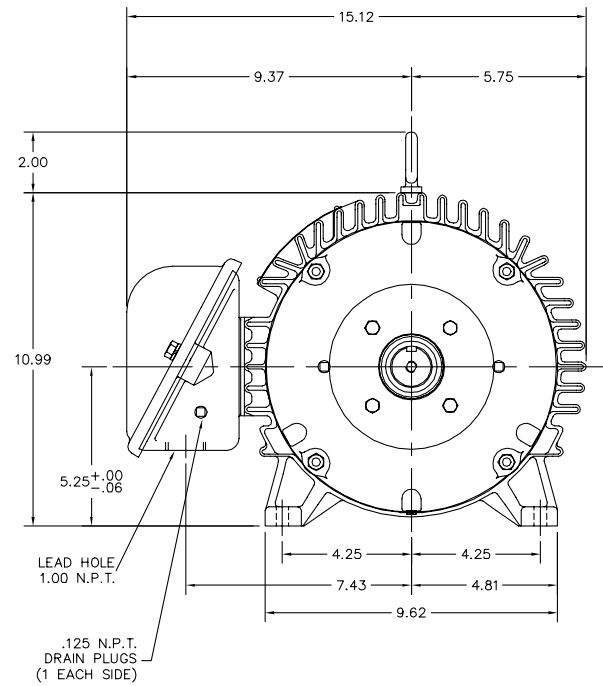
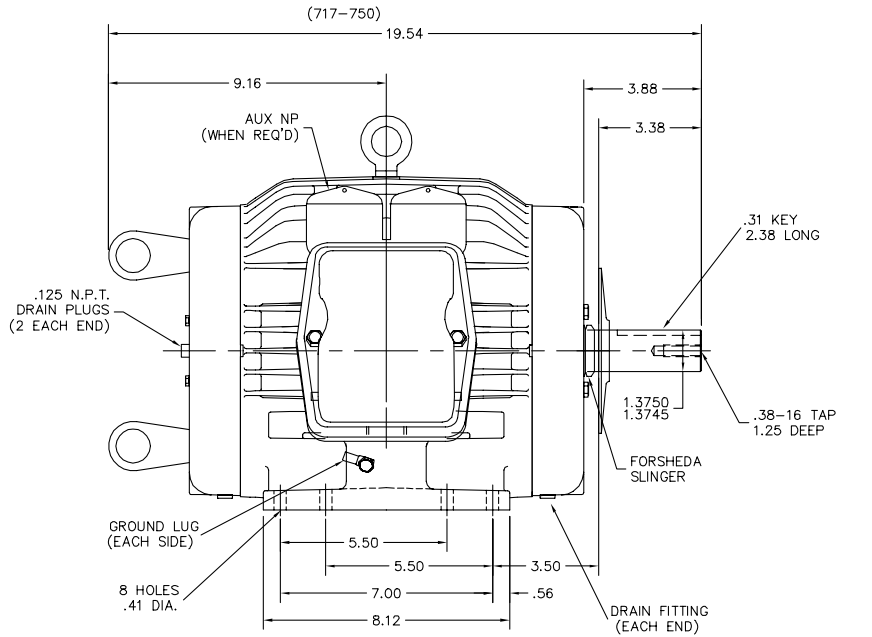

NOTE:  
FOR VERTICAL SHAFT UP LIFTING,  
REMOVE EYE BOLT FROM TOP OF MOTOR  
AND SCREW INTO END OF SHAFT

CUSTOMER IS RESPONSIBLE FOR DETERMINING THAT BALDOR'S PRODUCT WILL PERFORM SUITABLY IN THE INTENDED APPLICATION.

REV. DESC: REPLACE 07SH2887 W/07SH2955	VERSION: 01	TDR: 000000964179
REV. LTR: A	REVISED: 08:26:01 02/02/2016	BY: ENALEMO
FILE: \AAA\00220\883	MTL: -	

**BALDOR**

HOR 213-5T TEAO CP COOL TOWER, LIFT, SLD BRGS, SEAL, DOME SL

SH 1 of 1

07LYN391

CD0005

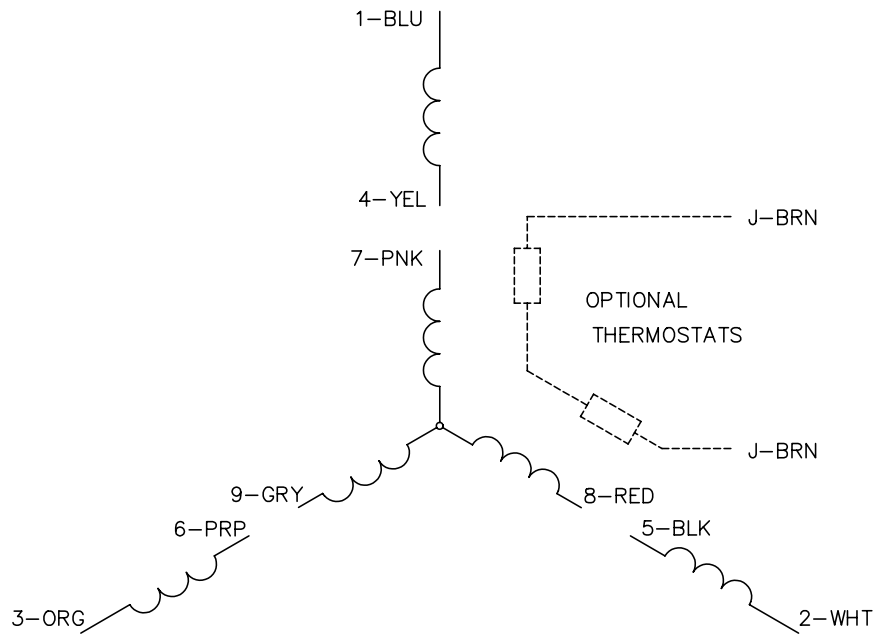

LOW VOLTAGE  
(2Y)



LINE

HIGH VOLTAGE  
(1Y)



LINE

NOTES:

1. INTERCHANGE ANY TWO LINE LEADS TO REVERSE ROTATION.
2. OPTIONAL THERMOSTATS ARE PROVIDED WHEN SPECIFIED.
3. ACTUAL NUMBER OF INTERNAL PARALLEL CIRCUITS MAY BE A MULTIPLE OF THOSE SHOWN ABOVE.
4. LEAD COLORS ARE OPTIONAL. LEADS MUST ALWAYS BE NUMBERED AS SHOWN.

REV. DESC: REVISE TO SHOW OPTIONAL COLORS

REV. LTR: E BY: JLP

REVISED: 01/19/99 10:15

TDR: 0171435

900003

FILE: AAA00005140

MDL: -

MTL: -

**BALDOR ELECTRIC Co.**

3PH, DV, 9 LEADS

CD0005