

BALDOR® • RELIANCE 

Product Information Packet

EJPM2514T

20HP,3510RPM,3PH,60HZ,254JP,3928M,OPSB,F

Part Detail							
Revision:	G	Status:	PRD/A	Change #:		Proprietary:	No
Type:	AC	Elec. Spec:	39WG101	CD Diagram:	CD0180	Mfg Plant:	
Mech. Spec:	39K61	Layout:	39LYK061	Poles:	02	Created Date:	05-14-2012
Base:	RG	Eff. Date:	10-31-2017	Leads:	9#10		

Specs			
Catalog Number:	EJPM2514T	Heater Indicator:	No Heater
Enclosure:	OPSB	Insulation Class:	F
Frame:	254JP	Inverter Code:	Inverter Ready
Frame Material:	Steel	KVA Code:	G
Output @ Frequency:	20.000 HP @ 60 HZ	Lifting Lugs:	Standard Lifting Lugs
Synchronous Speed @ Frequency:	3600 RPM @ 60 HZ	Locked Bearing Indicator:	Locked Bearing
Voltage @ Frequency:	460.0 V @ 60 HZ	Motor Lead Quantity/Wire Size:	9 @ 10 AWG
	230.0 V @ 60 HZ	Motor Lead Exit:	Ko Box
XP Class and Group:	None	Motor Lead Termination:	Flying Leads
XP Division:	Not Applicable	Motor Type:	3928M
Agency Approvals:	UR	Mounting Arrangement:	F1
	CSA EEV	Power Factor:	88
	CSA	Product Family:	General Purpose
Auxillary Box:	No Auxillary Box	Pulley End Bearing Type:	Ball
Auxillary Box Lead Termination:	None	Pulley Face Code:	C-Face
Base Indicator:	Rigid	Pulley Shaft Indicator:	Tapped & Key
Bearing Grease Type:	Polyrex EM (-20F +300F)	Rodent Screen:	Included
Blower:	None	Shaft Extension Location:	Pulley End

Current @ Voltage:	23.500 A @ 460.0 V	Shaft Ground Indicator:	No Shaft Grounding
	47.000 A @ 230.0 V	Shaft Rotation:	Reversible
	51.000 A @ 208.0 V	Shaft Slinger Indicator:	Shaft Slinger
Design Code:	A	Speed Code:	Single Speed
Drip Cover:	No Drip Cover	Motor Standards:	NEMA
Duty Rating:	CONT	Starting Method:	Direct on line
Electrically Isolated Bearing:	Not Electrically Isolated	Thermal Device - Bearing:	NONE (OLD)
Feedback Device:	NO FEEDBACK	Thermal Device - Winding:	None
Front Face Code:	Standard	Vibration Sensor Indicator:	No Vibration Sensor
Front Shaft Indicator:	None	Winding Thermal 1:	None
		Winding Thermal 2:	None

Nameplate NP1259L													
CAT.NO.	EJPM2514T												
SPEC.	39K061X101G1												
HP	20												
VOLTS	230/460												
AMP	47/23.5												
RPM	3510												
FRAME	254JP					HZ	60			PH	3		
SER.F.	1.15					CODE	G		DES	A		CL	F
NEMA-NOM-EFF	91					PF	88						
RATING	40C AMB-CONT												
CC	010A									USABLE AT 208V	51		
DE	6309					ODE	6208						
ENCL	OPSB					SN							

Parts List		
Part Number	Description	Quantity
SA244391	SA 39K061X101G1	1.000 EA
RA231277	RA 39K061X101G1	1.000 EA
S/P107-000-005	SUPER-E PROC'S(254/6 FR.) ZK PLANT - POL	1.000 EA
HA6361A01	LIFTING LUG FOR 37, 39 & 40 FRAME ZINC	2.000 EA
HA6016	ADAPTER, CAST CONDUIT BOX	1.000 EA
09CB3002SP	CB W/1.38 LEAD HOLE FOR 37, 39, 307 & 30	1.000 EA
51XW2520A12	.25-20 X .75, TAPTITE II, HEX WSHR SLTD	2.000 EA
HW1001A25	LOCKWASHER 1/4, ZINC PLT .493 OD, .255 I	2.000 EA
WD1000B16	T&B CX70TN TERMINAL	1.000 EA
59XW2520G07	.25-20X.44,HEX SER WSHR,TAPTITE 2,GREEN	1.000 EA
39EP3200A01SP	FR/PU ENDPLATE, MACH	1.000 EA
HA4051A00	PLASTIC CAP FOR GREASE FITTING	1.000 EA
HA1101A01	RODENT SCREEN, 39 MTR	1.000 EA
11XW1032G06	10-32 X .38, TAPTITE II, HEX WSHR SLTD U	4.000 EA
HW5100A08	W3118-035 WVY WSHR (WB)	1.000 EA
10XN2520K28	1/4-20 X 1.75" HX HD SCRWGRADE 5, ZINC P	4.000 EA
HW1001A25	LOCKWASHER 1/4, ZINC PLT .493 OD, .255 I	4.000 EA
39EP3400A03	STD FACE MTD ENDPLATE, 309 BRG W/BAFFLE	1.000 EA
HA4051A00	PLASTIC CAP FOR GREASE FITTING	1.000 EA
HA1101A03	RODENT SCREEN, 39 FACE MTD.E.P.	1.000 EA
11XW1032G06	10-32 X .38, TAPTITE II, HEX WSHR SLTD U	4.000 EA
HA2009A04	39-81 SLINGER (STERLING)	1.000 EA
80XN1032A06	10-32 X 3/8 SET SC HEX SOCK	1.000 EA
XY3816A12	3/8-16 FINISHED NUT	8.000 EA

Parts List (continued)		
Part Number	Description	Quantity
09CB3501SP	CONDUIT BOX LID FOR 09CB3001 & 09CB3002	1.000 EA
51XW2520A12	.25-20 X .75, TAPTITE II, HEX WSHR SLTD	2.000 EA
HW2501E18	KEY, 1/4 SQ X 2.000	1.000 EA
LB1115N	LABEL,LIFTING DEVICE (ON ROLLS)	1.000 EA
HW4500A03	GREASE FITTING, .125 NPT 1610(ALEMITE) 8	1.000 EA
HW4500A20	1/8NPT SL PIPE PLUG	1.000 EA
MJ1000A02	GREASE, POLYREX EM EXXON (USe 4824-15A)	0.030 LB
HW4500A03	GREASE FITTING, .125 NPT 1610(ALEMITE) 8	1.000 EA
HW4500A20	1/8NPT SL PIPE PLUG	1.000 EA
MG1000Y03	MUNSELL 2.53Y 6.70/ 4.60, GLOSS 20,	0.050 GA
85XU0407S04	4X1/4 U DRIVE PIN STAINLESS	2.000 EA
MN416A01	TAG-INSTAL-MAINT no wire (1200/bx) 5/18	1.000 EA
39AD2002C01	BAFFLE PLATE,"X" DIM=2.12 OPEN SLOT BAND	1.000 EA
39AD2002C01	BAFFLE PLATE,"X" DIM=2.12 OPEN SLOT BAND	1.000 EA
HA3154A09	TB STUD 3/8-16 X 16.25	4.000 EA
LB1119N	WARNING LABEL	1.000 EA
LC0181	CONNECTION LABEL	1.000 EA
NP1259L	ALUM SUPER-E UL CSA-EEV CC NEMA PREMIUM	1.000 EA
40PA1000	PACKAGING GROUP	1.000 EA

AC Induction Motor Performance Data

Record # 13049 - Typical performance - not guaranteed values

Winding: 39WGX101-R004	Type: 3928M	Enclosure: OPSB
-------------------------------	--------------------	------------------------

Nameplate Data				460 V, 60 Hz: High Voltage Connection	
Rated Output (HP)	20			Full Load Torque	29.6 LB-FT
Volts	230/460			Start Configuration	direct on line
Full Load Amps	47/23.5			Breakdown Torque	111 LB-FT
R.P.M.	3510			Pull-up Torque	36.1 LB-FT
Hz	60	Phase	3	Locked-rotor Torque	50.6 LB-FT
NEMA Design Code	B	KVA Code	G	Starting Current	153 A
Service Factor (S.F.)	1.15			No-load Current	8.61 A
NEMA Nom. Eff.	91	Power Factor	88	Line-line Res. @ 25°C	0.512 Ω
Rating - Duty	40C AMB-CONT			Temp. Rise @ Rated Load	44°C
S.F. Amps				Temp. Rise @ S.F. Load	54°C
				Locked-rotor Power Factor	30
				Rotor inertia	0.715 LB-FT ²

Load Characteristics 460 V, 60 Hz, 20 HP

% of Rated Load	25	50	75	100	125	150	S.F.
Power Factor	52	74	83	87	89	89	88
Efficiency	84.7	90.1	91.2	91	90.1	89.1	90.5
Speed	3581	3563	3544	3522	3496	3472	3506
Line amperes	10.2	13.9	18.1	23.3	29.1	35	26.78

Performance Graph at 460V, 60Hz, 20.0HP Typical performance - Not guaranteed values

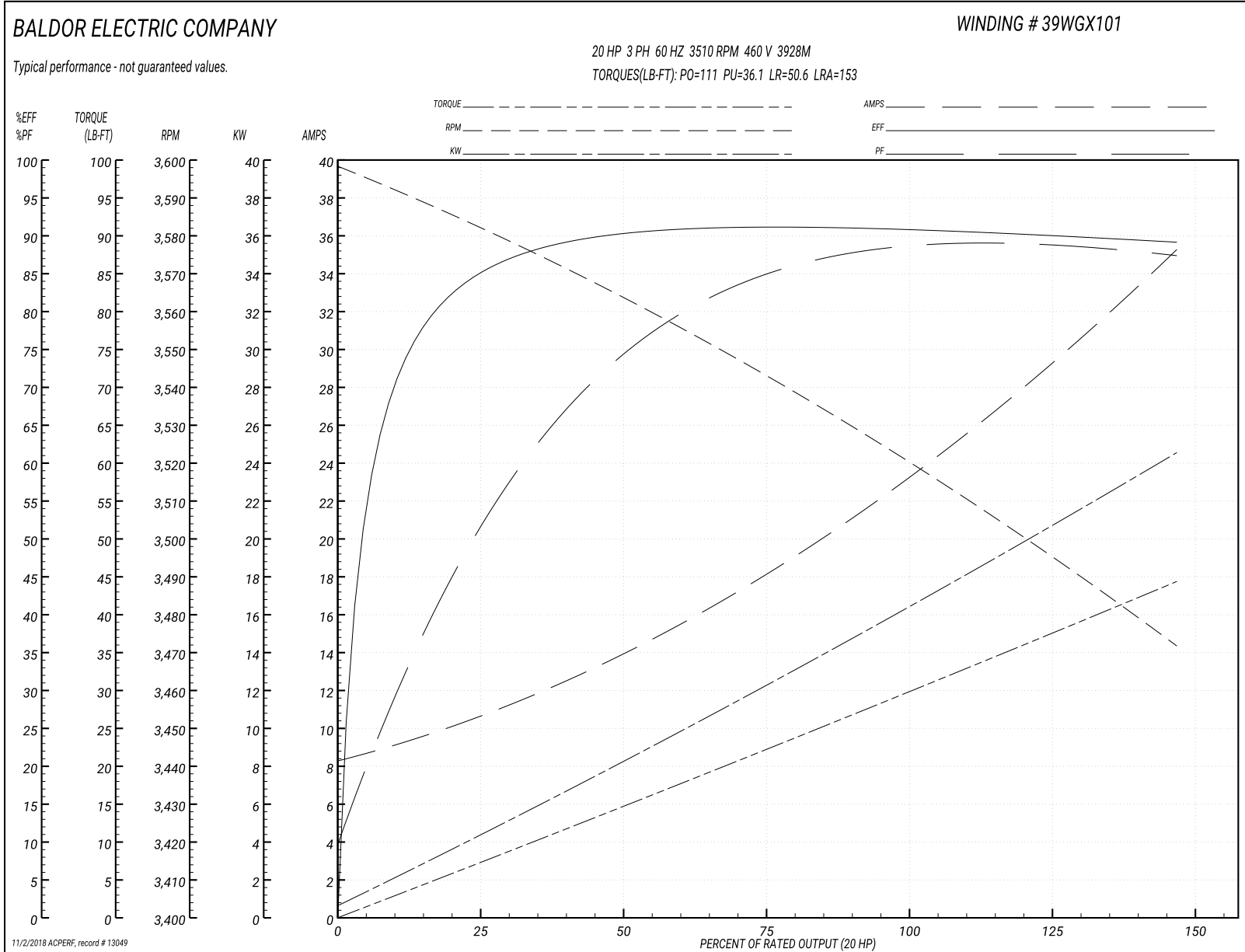

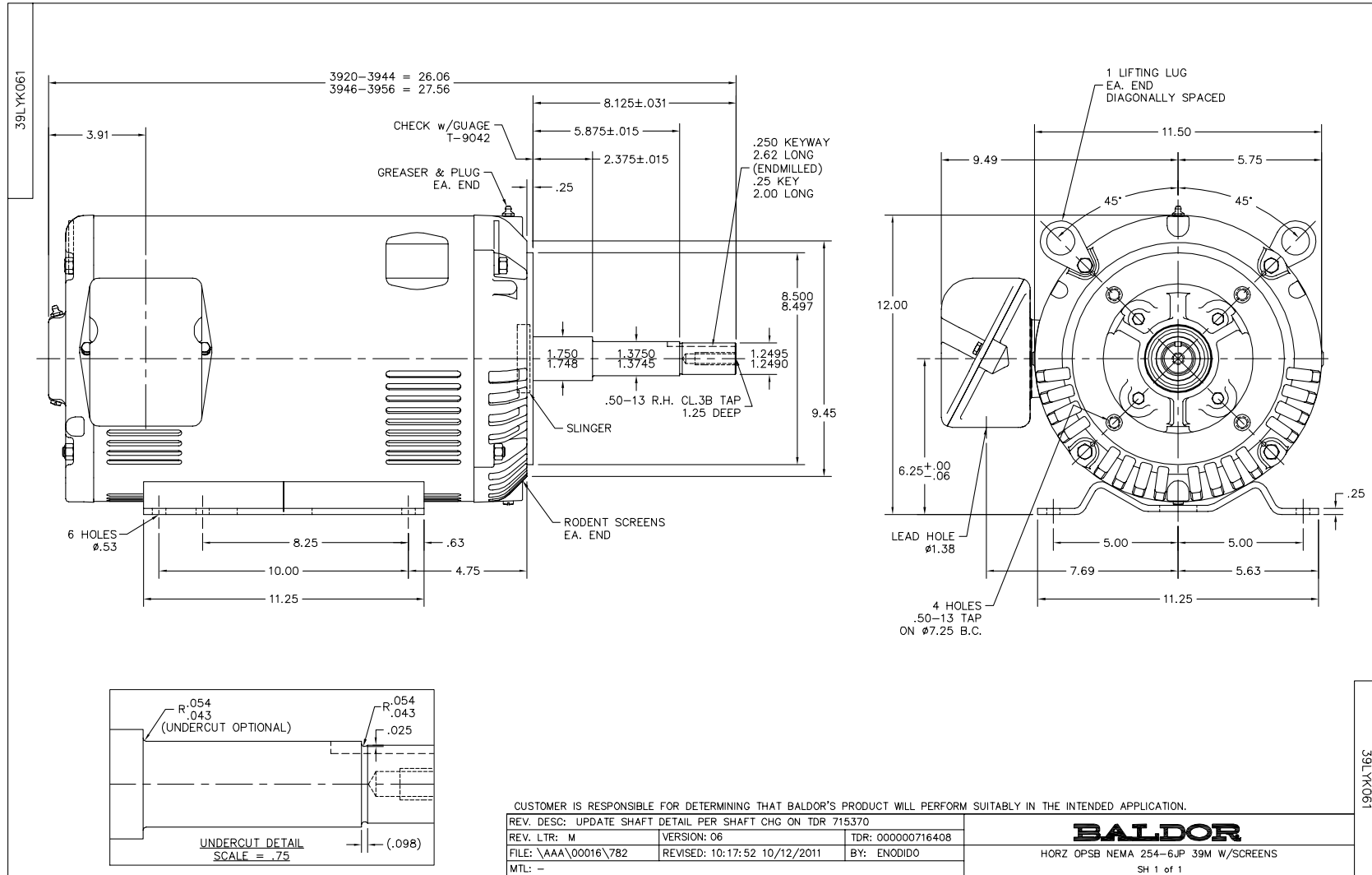

CD0180



LOW VOLTAGE
(2D)



HIGH VOLTAGE
(1D)

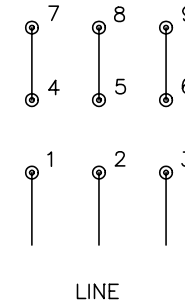

NOTES:

1. INTERCHANGE ANY TWO LINE LEADS TO REVERSE ROTATION.
2. OPTIONAL THERMOSTATS ARE PROVIDED WHEN SPECIFIED.
3. ACTUAL NUMBER OF INTERNAL PARALLEL CIRCUITS MAY BE A MULTIPLE OF THOSE SHOWN ABOVE.
4. LEAD COLORS ARE OPTIONAL. LEADS MUST ALWAYS BE NUMBERED AS SHOWN.

REV. DESC: REVISE TO SHOW OPTIONAL COLORS			
REV. LTR: C	BY: JLP	REVISED: 01/21/99 2:28	TDR: 0171435
0810D0		FILE: AAA00005148	MDL: -
		MTL: -	

BALDOR ELECTRIC Co.

3PH, DV, 9 LEADS, DELTA CONNECTION

CD0180