

DUTY MASTER ALTERNATING CURRENT MOTORS

ENCLOSURE: TOTALLY ENCLOSED

SQUIRREL-CAGE INDUCTION

COOLING: OPEN DRIP-PROOF

MOUNTING: FOOT, F-1

FRAME E447TS

STEEL CONDUIT BOX

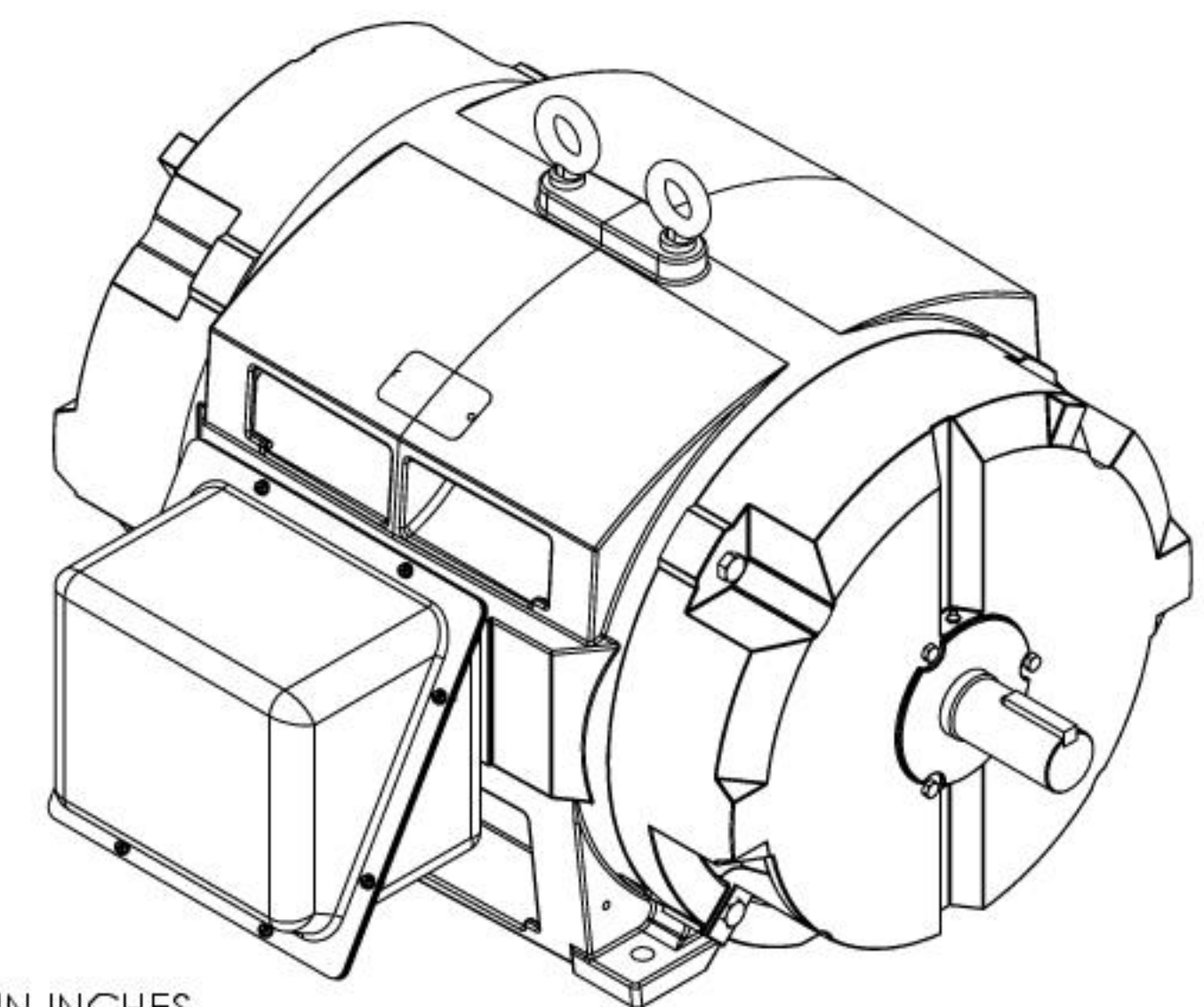
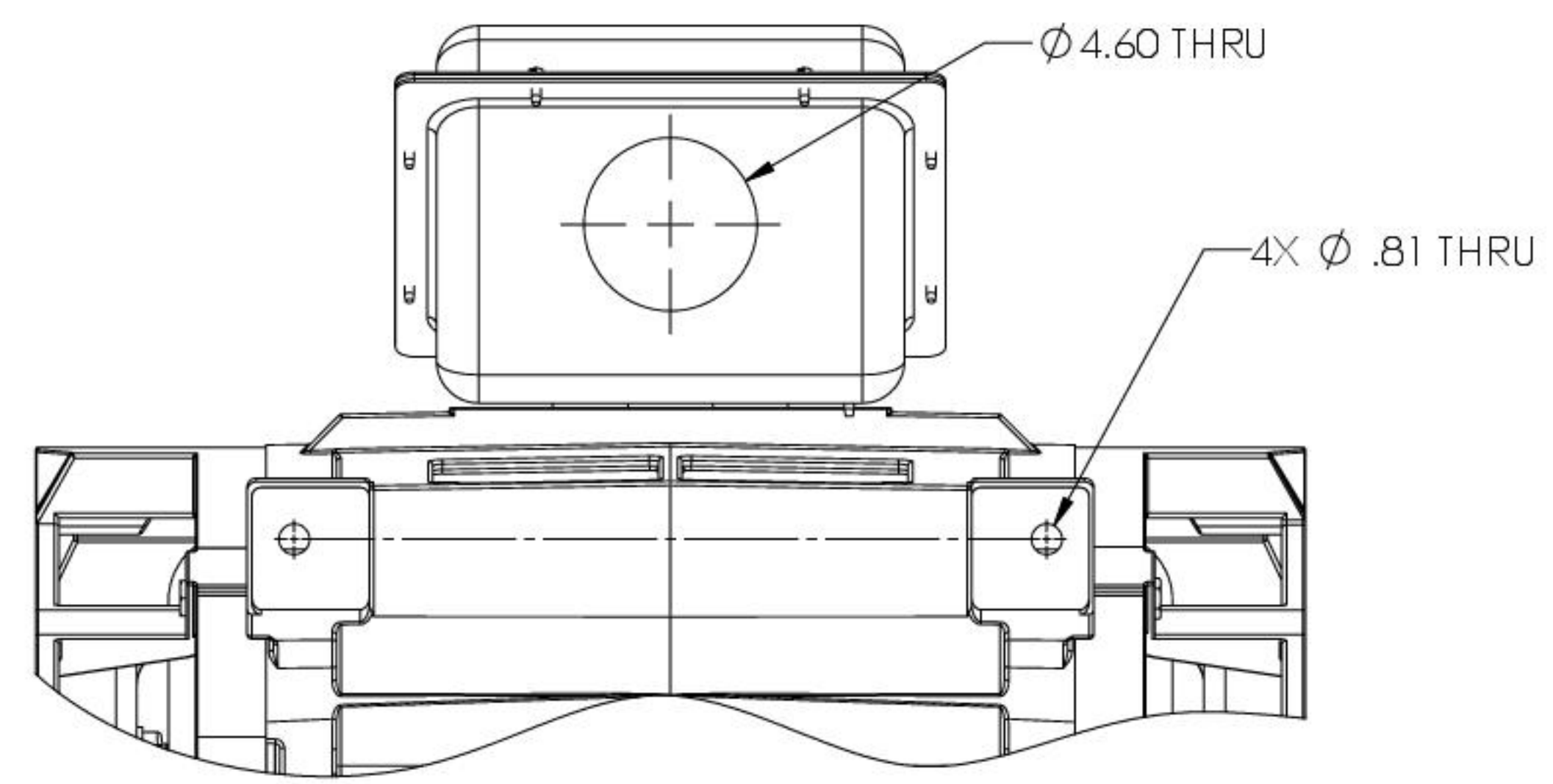
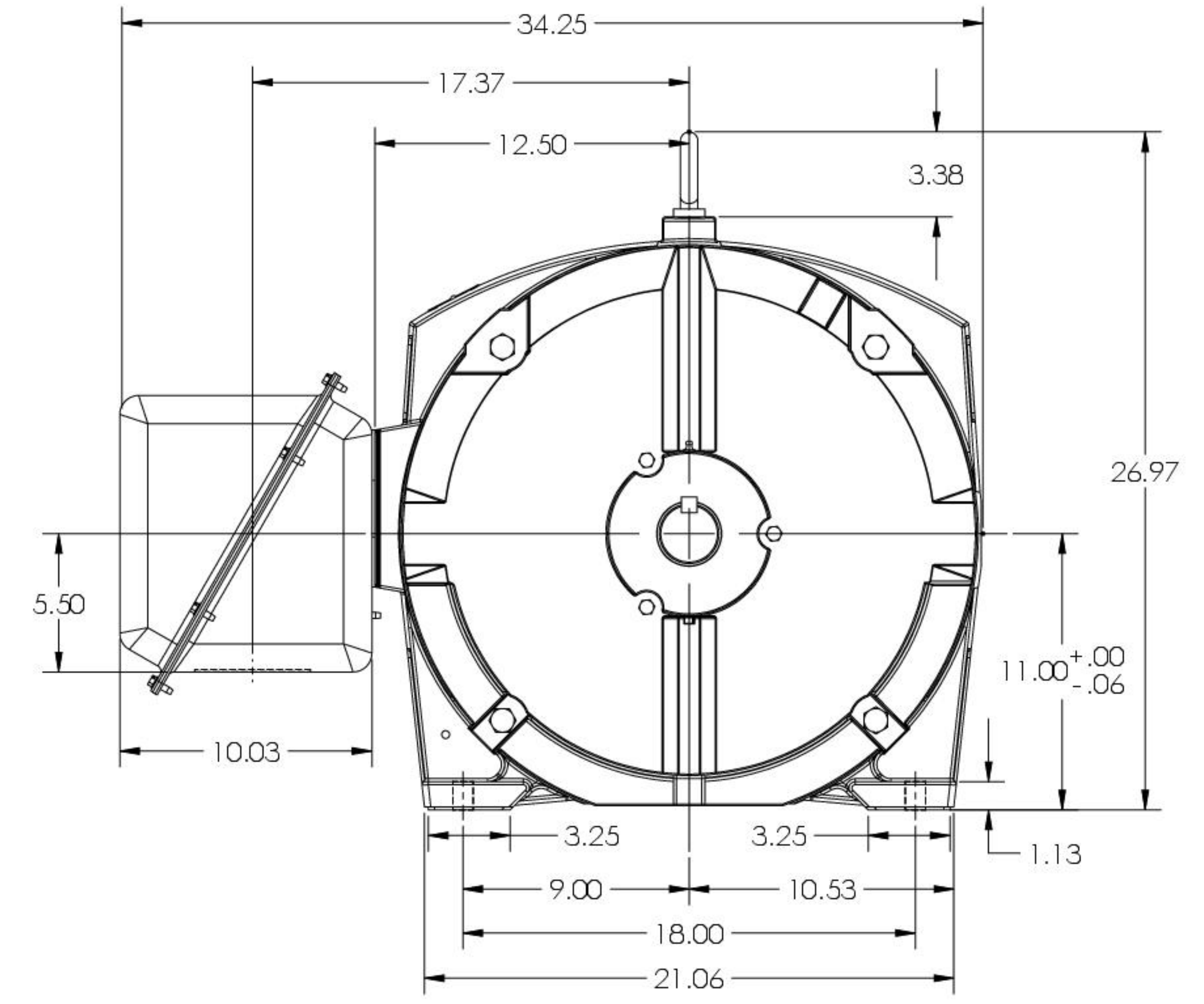
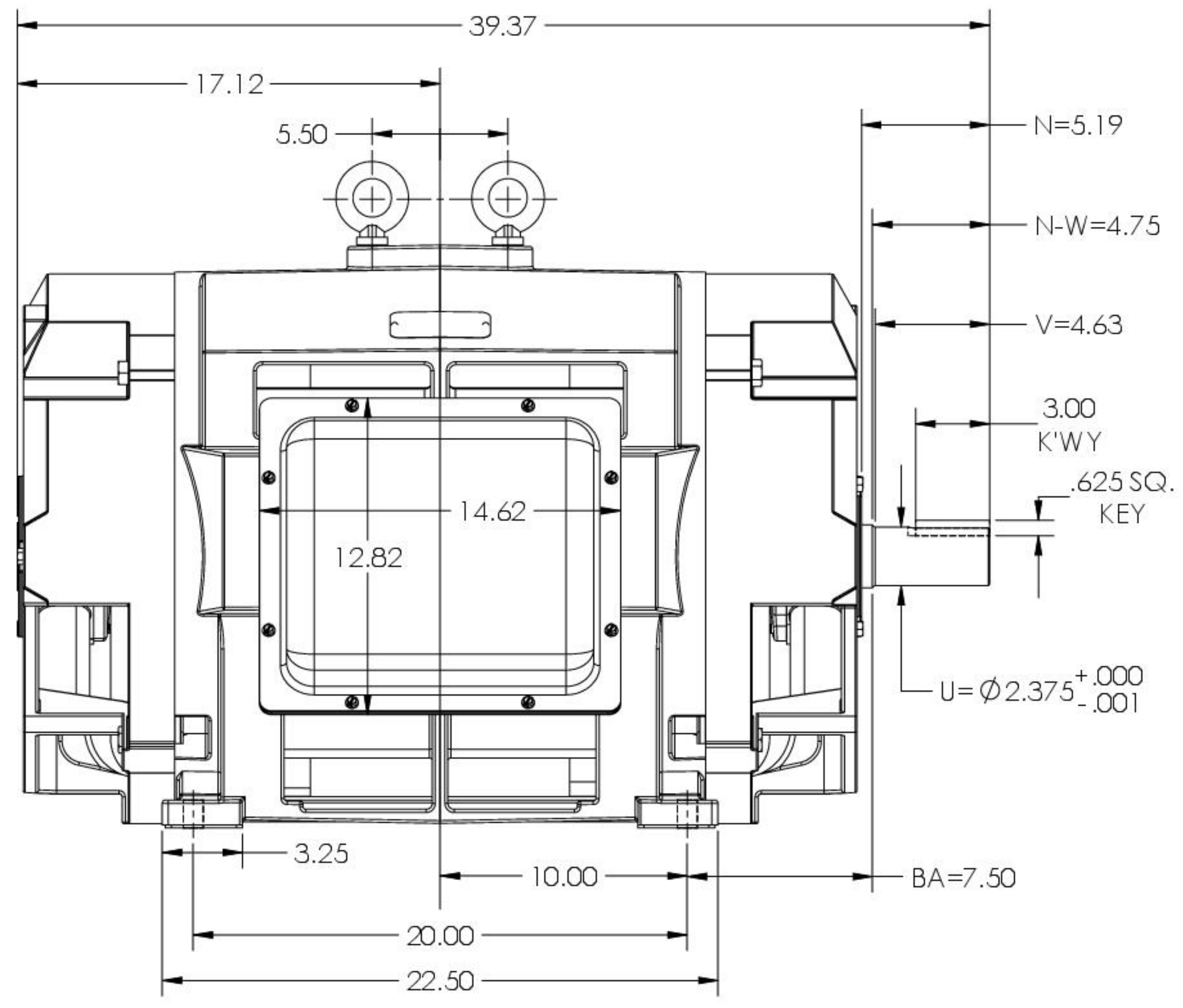

DIMENSIONS ARE IN INCHES

CUSTOMER IS RESPONSIBLE FOR DETERMINING THAT MOTOR PERFORMANCE IS SUITABLE IN THE APPLICATION.

CONDUIT BOX LOCATED ON OPPOSITE SIDE WHEN F-2. IF MOUNTING CLEARANCE DETAILS ARE REQUIRED, CONSULT FACTORY. MAXIMUM PERMISSIBLE SHAFT RUNOUT WHEN MEASURED AT END OF STANDARD SHAFT EXTENSION IS .003" T.I.R.

REV. DESC: UPDATE MODEL TO ADD EXTERNAL HARDWARE PER PROD MGM			
REV: B	VERSION: 02	REVISED: 07.46.15 07/14/2022	TD R: 000001193 529
MODEL NO. 604989-483			
BY: USBUFRA		C	