

BALDOR® • RELIANCE 

Product Information Packet

EM4117T-G

30HP,1180RPM,3PH,60HZ,326T,1264M,TEFC,F1

Part Detail							
Revision:	F	Status:	PRD/A	Change #:		Proprietary:	No
Type:	AC	Elec. Spec:	12WGY812	CD Diagram:	CD0005	Mfg Plant:	
Mech. Spec:	12F882	Layout:	12LYF882	Poles:	06	Created Date:	09-15-2014
Base:	RG	Eff. Date:	09-07-2017	Leads:	9#8		

Specs			
Catalog Number:	EM4117T-G	Insulation Class:	H
Enclosure:	TEFC	Inverter Code:	Not Inverter
Frame:	326T	KVA Code:	H
Frame Material:	Iron	Lifting Lugs:	Standard Lifting Lugs
Output @ Frequency:	30.000 HP @ 60 HZ	Locked Bearing Indicator:	Locked Bearing
Synchronous Speed @ Frequency:	1200 RPM @ 60 HZ	Motor Lead Quantity/Wire Size:	9 @ 8 AWG
Voltage @ Frequency:	460.0 V @ 60 HZ	Motor Lead Exit:	Ko Box
	230.0 V @ 60 HZ	Motor Lead Termination:	Flying Leads
XP Class and Group:	None	Motor Type:	1264M
XP Division:	Not Applicable	Mounting Arrangement:	F1
Agency Approvals:	CSA	Power Factor:	78
	CSA EEV	Product Family:	General Purpose
	UR	Pulley End Bearing Type:	Ball
Auxillary Box:	No Auxillary Box	Pulley Face Code:	Standard
Auxillary Box Lead Termination:	None	Pulley Shaft Indicator:	Standard
Base Indicator:	Rigid	Rodent Screen:	None
Bearing Grease Type:	Polyrex EM (-20F +300F)	Shaft Extension Location:	Pulley End
Blower:	None	Shaft Ground Indicator:	Shaft Grounding

Current @ Voltage:	39.000 A @ 460.0 V	Shaft Rotation:	Reversible
	78.000 A @ 230.0 V	Shaft Slinger Indicator:	Shaft Slinger
Design Code:	A	Speed Code:	Single Speed
Drip Cover:	No Drip Cover	Motor Standards:	NEMA
Duty Rating:	CONT	Starting Method:	Direct on line
Electrically Isolated Bearing:	Not Electrically Isolated	Thermal Device - Bearing:	NONE (OLD)
Feedback Device:	NO FEEDBACK	Thermal Device - Winding:	None
Front Face Code:	Standard	Vibration Sensor Indicator:	No Vibration Sensor
Front Shaft Indicator:	None	Winding Thermal 1:	None
Heater Indicator:	No Heater	Winding Thermal 2:	None

Nameplate NP3443L										
CAT.NO.	EM4117T-G				CUST. P/N				ENCL	TEFC
SPEC.	12F882Y812G1		CC	010A	FRAME	326T		SER.NO.		
HP	30		CLASS	H	HZ	60				
R.P.M.	1180		PH	3	DES	A				
VOLTS	230/460		CODE	H	ODE BRG	6311		DE BRG	6312	
AMPS	78/39		USABLE AT 208V							
RATING	40C AMB-CONT		NEMA NOM. EFF.	93		GREASE	POLYREX EM			
P.F.	78	SER.F.	1.15		VPWM INVERTER READY					
HTR-VOLTS			HTR-AMPS			HTR-WATTS				

Parts List		
Part Number	Description	Quantity
SA287144	SA 12F882Y812G1	1.000 EA
RA273360	RA 12F882Y812G1	1.000 EA
09FN3001B03SP	EXTERNAL FAN, PLASTIC	1.000 EA
S/P107-000-004	SUPER-E(284 FR. & UP)-CL PLANT,POLYREX E	1.000 EA
10CB3001	CONDUIT BOX CAST W/2.500 LEAD HOLE	1.000 EA
12GS1000SP	GASKET	1.000 EA
10XN3118K12	5/16-18 X .75 GRADE 5, ZINC PLATED	4.000 EA
HW1001A31	LOCKWASHER 5/16, ZINC PLT.591 OD, .319 I	4.000 EA
WD1000B25	GND LUG, BURNDY L125HP OR T&B L125HP-BB	1.000 EA
19XW3118G08	.31-18X.50,HEX WSHR HD,TAPTITE 2,GREEN	1.000 EA
12EP1107A05	FR ENDPLATE, MACH 324-6T	1.000 EA
HA3400A13	STUD, 1/2-13 X 7" WELKER	4.000 EA
HW1001A50	LOCKWASHER 1/2, ZINC PLT.,.879 OD, .509 I	4.000 EA
HW5100A13	W4627-047 WVY WSHER	1.000 EA
10XN3118K36	5/16-18 X 2.25" HEX HD, GRADE 5	2.000 EA
HW1001A31	LOCKWASHER 5/16, ZINC PLT.591 OD, .319 I	2.000 EA
12EP1106A01	PU ENDPLATE, MACH 324-6T	1.000 EA
10XN5013K28	1/2-13 X 1.75 HEX HEAD MACH SCREW,GRAD	4.000 EA
HW1001A50	LOCKWASHER 1/2, ZINC PLT.,.879 OD, .509 I	4.000 EA
HW4600B41	V-RING SLINGER 2.125 X 2.880 X 0.280	1.000 EA
10XN3118K36	5/16-18 X 2.25" HEX HD, GRADE 5	4.000 EA
HW1001A31	LOCKWASHER 5/16, ZINC PLT.591 OD, .319 I	4.000 EA
12FH1002SP	FAN COVER, CAST	1.000 EA
XY5013A12	NUT,1/2-13,HEX,STEEL,ZINCPLATED	4.000 EA

Parts List (continued)		
Part Number	Description	Quantity
HW1001A50	LOCKWASHER 1/2, ZINC PLT.,.879 OD, .509 I	4.000 EA
10CB3500SP	CONDUIT BOX LID, CAST	1.000 EA
10GS1000SP	GASKET, CONDUIT BOX LID	1.000 EA
51XW2520A12	.25-20 X .75, TAPTITE II, HEX WSHR SLTD	4.000 EA
HW2501H33	KEY, 1/2 SQ X 3.875	1.000 EA
LB1115N	LABEL,LIFTING DEVICE (ON ROLLS)	1.000 EA
HW4500A21	1618BALEMITE FITTING 825 UNIVERSAL	1.000 EA
HA4017A01	1/8 X 4 GREASE EXT (F/S)	1.000 EA
HW4500A17	317400 ALEMITE GREASE RELIEF	1.000 EA
HA4054	SHORT T-DRAIN FITTING, .125" N.P.T.	1.000 EA
HA4051A00	PLASTIC CAP FOR GREASE FITTING	1.000 EA
MJ1000A02	GREASE, POLYREX EM EXXON (USe 4824-15A)	0.200 LB
HW4500A03	GREASE FITTING, .125 NPT 1610(ALEMITE) 8	1.000 EA
HW4500A17	317400 ALEMITE GREASE RELIEF	1.000 EA
HA4054	SHORT T-DRAIN FITTING, .125" N.P.T.	1.000 EA
HA4051A00	PLASTIC CAP FOR GREASE FITTING	1.000 EA
HW2500A25	WOODRUFF KEY USA #1008 #BLOW CARBON STEE	1.000 EA
51XB1214A20	12-14X1.25 HXWSSLD SERTYB	1.000 EA
MG1000Y03	MUNSELL 2.53Y 6.70/ 4.60, GLOSS 20,	0.080 GA
85XU0407S04	4X1/4 U DRIVE PIN STAINLESS	4.000 EA
LB1119N	WARNING LABEL	1.000 EA
LC0005	CONN.DIA.,TY M,9-LD,DUAL VOLT,REVERSING	1.000 EA
NP3443L	SS SUPER-E UL CSA-EEV PREM CC	1.000 EA
12PA1000	PACKAGING GROUP PRINT PK1024A06	1.000 EA

Product Information Packet: EM4117T-G - 30HP,1180RPM,3PH,60HZ,326T,1264M,TEFC,F1

MN416A01	TAG-INSTAL-MAINT no wire (1200/bx) 5/18	1.000 EA
LB1350	BAR CODE LABEL FOR YORK	1.000 EA

AC Induction Motor Performance Data

Record # 47206 - Typical performance - not guaranteed values

Winding: 12WGY812-R005	Type: 1264M	Enclosure: TEFC
-------------------------------	--------------------	------------------------

Nameplate Data				460 V, 60 Hz: High Voltage Connection	
Rated Output (HP)	30			Full Load Torque	133 LB-FT
Volts	230/460			Start Configuration	direct on line
Full Load Amps	78/39			Breakdown Torque	370 LB-FT
R.P.M.	1180			Pull-up Torque	179 LB-FT
Hz	60	Phase	3	Locked-rotor Torque	217 LB-FT
NEMA Design Code	A	KVA Code	H	Starting Current	245 A
Service Factor (S.F.)	1.15			No-load Current	17.2 A
NEMA Nom. Eff.	93	Power Factor	78	Line-line Res. @ 25°C	0.22799 Ω
Rating - Duty	40C AMB-CONT			Temp. Rise @ Rated Load	56°C
S.F. Amps				Temp. Rise @ S.F. Load	68°C

Load Characteristics 460 V, 60 Hz, 30 HP

% of Rated Load	25	50	75	100	125	150	S.F.
Power Factor	42	63	73	78	80	80	79
Efficiency	89	92.7	93.4	93.1	92.4	91.4	92.7
Speed	1196.5	1191.9	1188.3	1183.2	1178.2	1171.8	1180
Line amperes	19.2	24.1	31	38.7	47.5	57.3	44

Performance Graph at 460V, 60Hz, 30.0HP Typical performance - Not guaranteed values

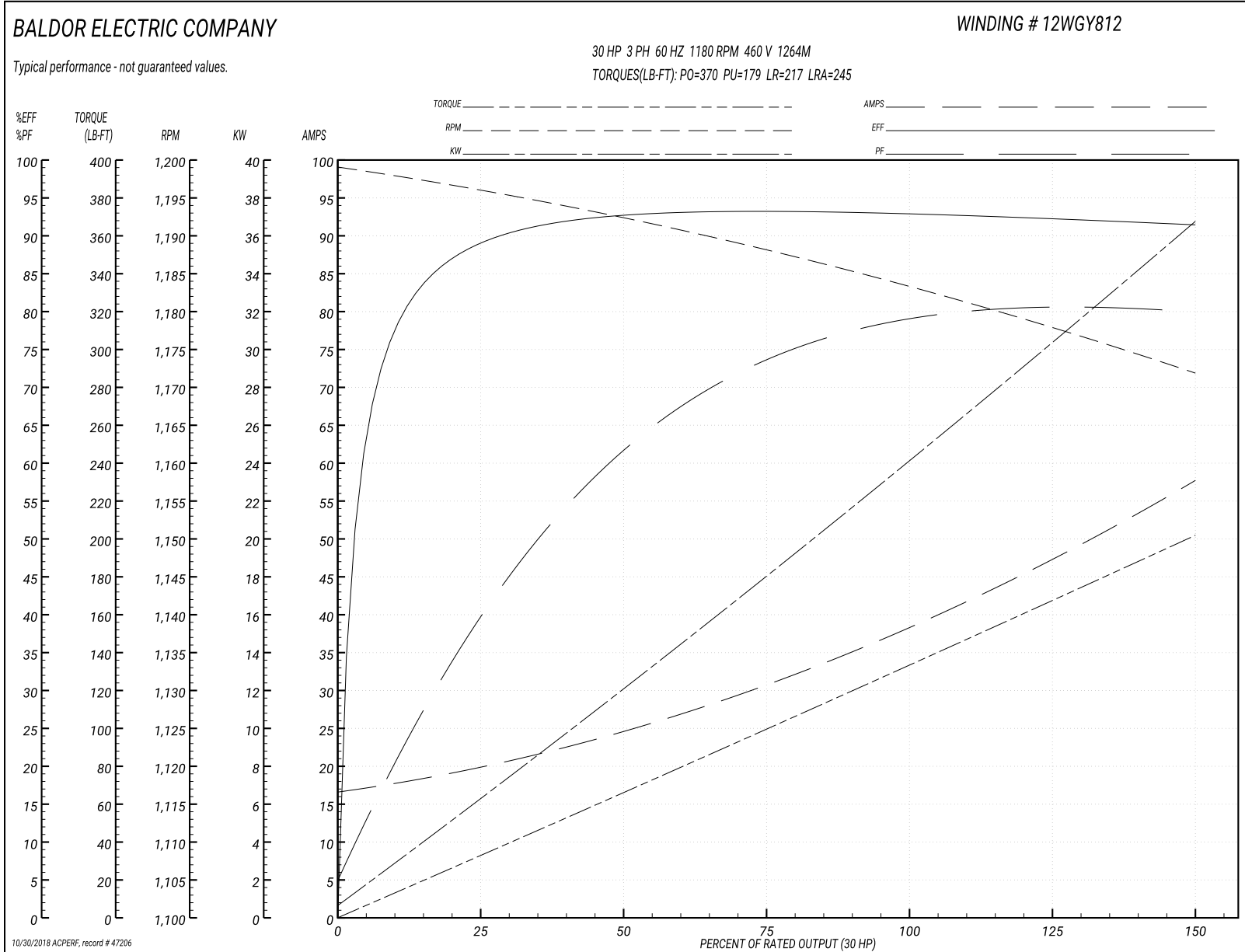

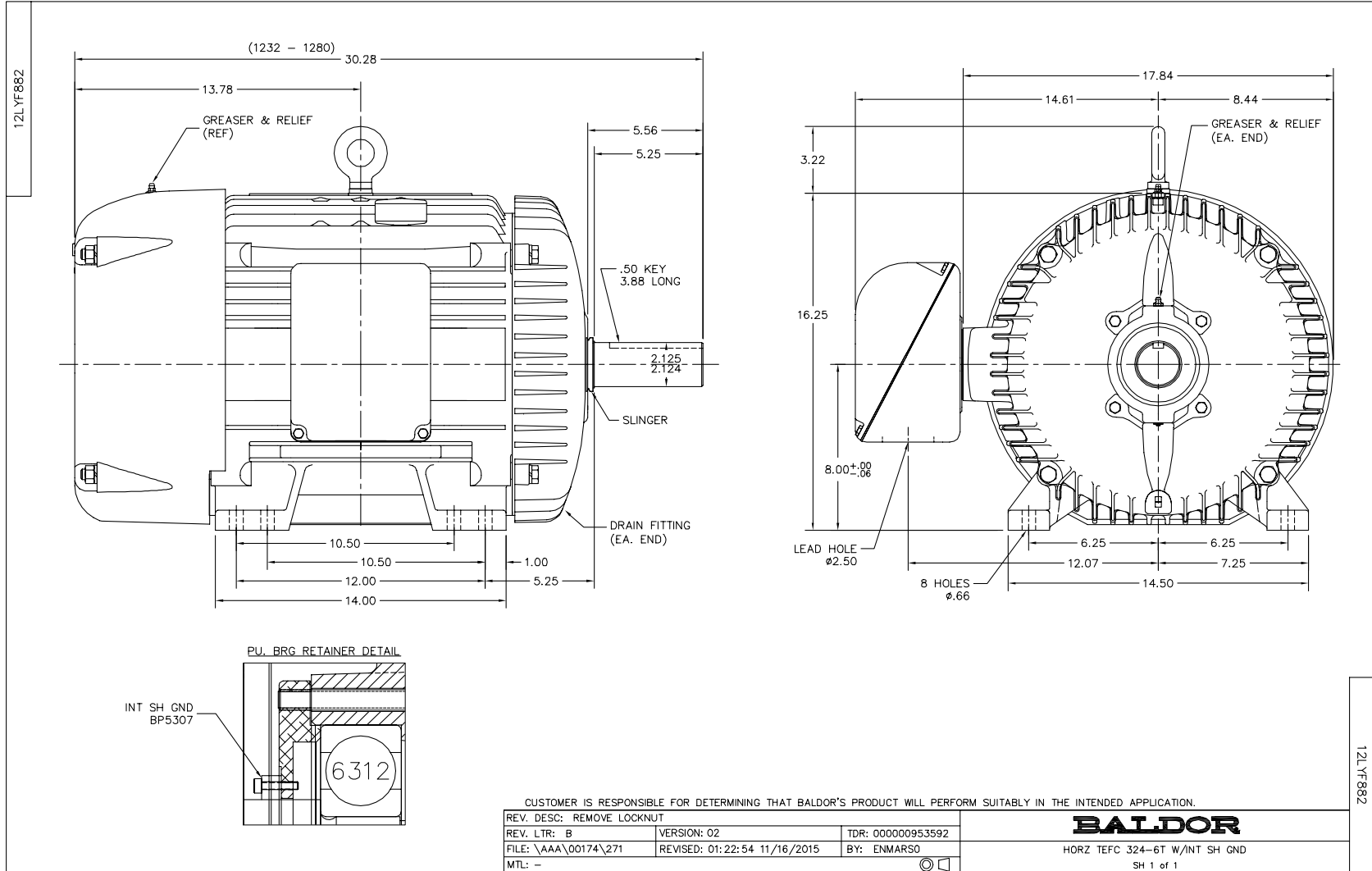

CD0005

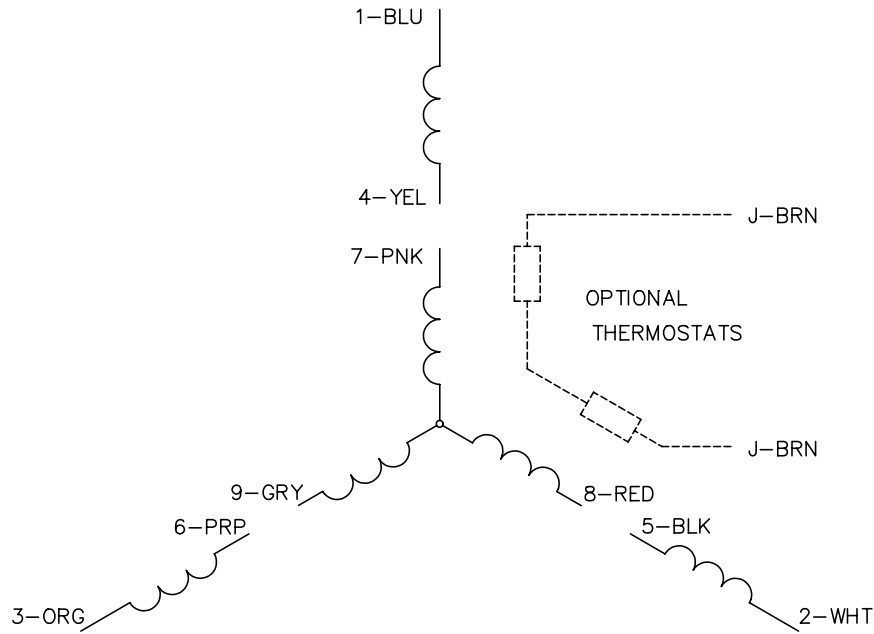

LOW VOLTAGE
(2Y)

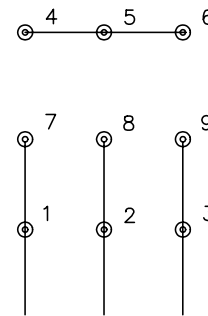

LINE

HIGH VOLTAGE
(1Y)

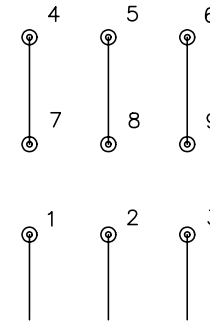

LINE

NOTES:

1. INTERCHANGE ANY TWO LINE LEADS TO REVERSE ROTATION.
2. OPTIONAL THERMOSTATS ARE PROVIDED WHEN SPECIFIED.
3. ACTUAL NUMBER OF INTERNAL PARALLEL CIRCUITS MAY BE A MULTIPLE OF THOSE SHOWN ABOVE.
4. LEAD COLORS ARE OPTIONAL. LEADS MUST ALWAYS BE NUMBERED AS SHOWN.

REV. DESC: REVISE TO SHOW OPTIONAL COLORS			
REV. LTR: E	BY: JLP	REVISED: 01/19/99 10:15	TDR: 0171435
90000		FILE: AAA00005140	MDL: -
		MTL: -	

BALDOR ELECTRIC Co.

3PH, DV, 9 LEADS

CD0005