

DUTY MASTER ALTERNATING CURRENT MOTORS

SQUIRREL-CAGE INDUCTION
CAST IRON CONSTRUCTION

ENCLOSURE: TOTALLY ENCLOSED
MOUNTING: FOOT

FRAMES 364TS-365TS

COOLING: FAN COOLED

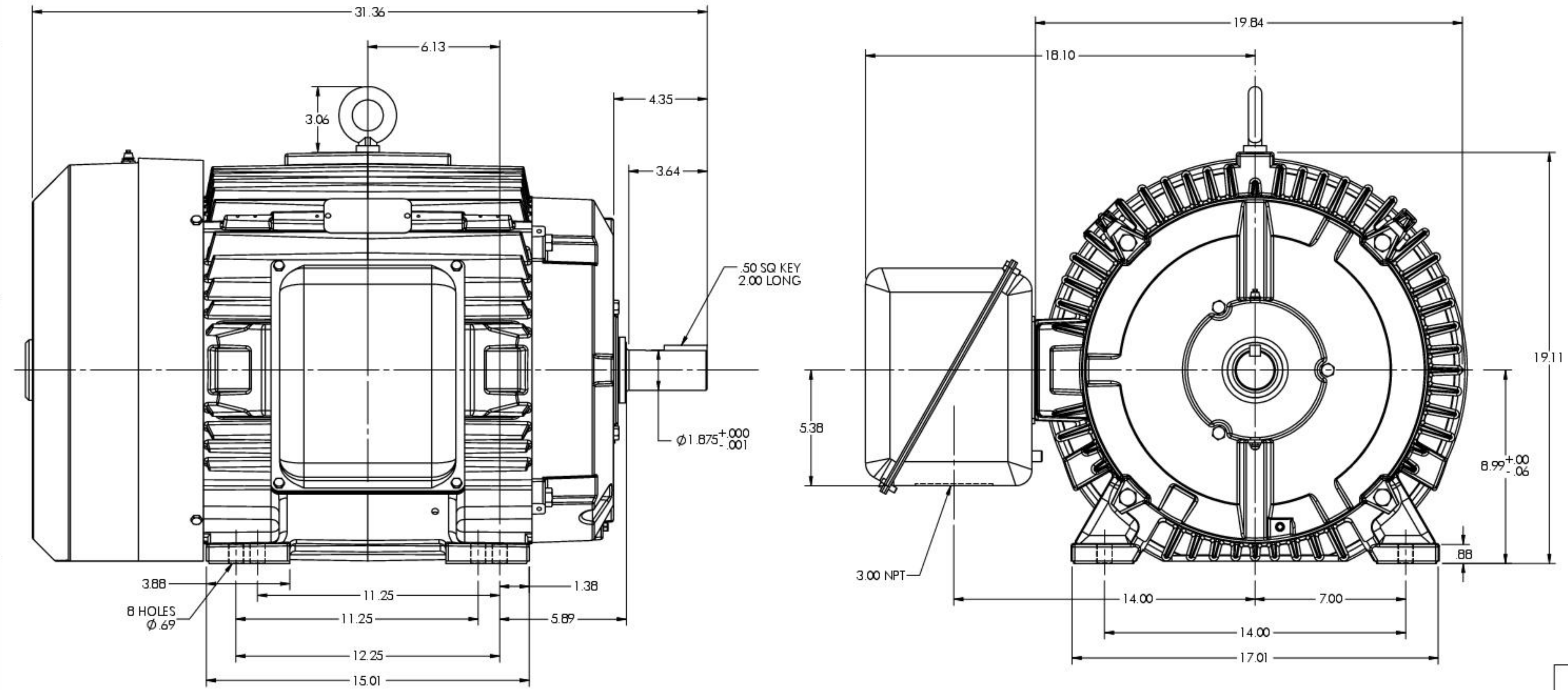

WEIGHT (LBS): 364TS = 794
365TS = 834
MOTOR WEIGHTS MAY VARY BY 15% DEPENDING UPON RATING.

REV. DESC: UPDATE MODEL TO ADD EXTERNAL HARDWARE PER PROD MGM			
REV: A	VERSION: 01	REVISED: 04:20:23 09/22/2022	TDR: 0000011965 12
MODEL NO. 617428-076		REF:	
BY: ENFRAJD		B	

BALDOR

HOR 364-5TS TEFC

CUSTOMER IS RESPONSIBLE FOR DETERMINING THAT BALDOR'S PRODUCT WILL PERFORM SUITABLY IN THE INTENDED APPLICATION

617428-076

617428-076