

**BALDOR® • RELIANCE** 

**Product Information Packet**

**EM4402T-4**

**100HP,3565RPM,3PH,60HZ,405TS,A40060M,TEF**

Part Detail							
Revision:	K	Status:	PRD/A	Change #:		Proprietary:	No
Type:	AC	Elec. Spec:	A40WG1270	CD Diagram:	416820-008	Mfg Plant:	
Mech. Spec:		Layout:	617429-002	Poles:	02	Created Date:	07-17-2013
Base:		Eff. Date:	07-09-2018	Leads:	6#4		

Specs			
Catalog Number:	EM4402T-4	Heater Indicator:	No Heater
Enclosure:	TEFC	Insulation Class:	F
Frame:	405TS	Inverter Code:	Inverter Ready
Frame Material:	Iron	KVA Code:	F
Output @ Frequency:	100.000 HP @ 60 HZ	Lifting Lugs:	Standard Lifting Lugs
Synchronous Speed @ Frequency:	3600 RPM @ 60 HZ	Motor Lead Quantity/Wire Size:	6 @ 4 AWG
Voltage @ Frequency:	460.0 V @ 60 HZ	Motor Type:	A40060M
XP Class and Group:	None	Mounting Arrangement:	F1
XP Division:	Not Applicable	Power Factor:	90
Agency Approvals:	CCSA US	Product Family:	General Industrial
	CSA EEV	Pulley End Bearing Type:	Ball
Auxillary Box:	No Auxillary Box	Pulley Face Code:	Standard
Base Indicator:	Rigid	Shaft Ground Indicator:	No Shaft Grounding
Bearing Grease Type:	Polyrex EM (-20F +300F)	Shaft Rotation:	Reversible
Current @ Voltage:	110.000 A @ 460.0 V	Shaft Slinger Indicator:	No Slinger
Design Code:	B	Speed Code:	Single Speed
Drip Cover:	No Drip Cover	Motor Standards:	NEMA
Duty Rating:	CONT	Starting Method:	Wye Start - Delta Run

<b>Feedback Device:</b>	NO FEEDBACK	<b>Thermal Device - Bearing:</b>	None
		<b>Thermal Device - Winding:</b>	None

Nameplate NP2383L									
CAT.NO.	EM4402T-4			SPEC NO.	P40G3929				
HP	100	AMPS	110	VOLTS	460	DESIGN	B		
FRAME	405TS	RPM	3565	HZ	60	AMB	40	SF	1.15
DRIVE END BEARING	65BC03J30X		PHASE	3	DUTY	CONT		INSUL.CLASS	F
OPP D.E. BEARING	65BC03J30X		TYPE	P	ENCL	TEFC	CODE	F	
SER.NO.				POWER FACTOR	90	NEMA-NOM-EFFICIENCY	95		
NEMA NOM/CSA QUOTED EFF				MAX CORR KVAR	10	GUARANTEED EFFICIENCY	94.1		
				MOTOR WEIGHT					

Parts List		
Part Number	Description	Quantity
SA267718	SA P40G3929	1.000 EA
RA254388	RA P40G3929	1.000 EA
000613006PU	N/P (RELEASE QTY 10,000) UL CSA LABEL	1.000 EA
NP2383L	SUPER-E ,SS, CC, CSA-C US, CSA EEV	1.000 EA
000692000FF	N/P	1.000 EA
000692000VD	LABEL WARNING	1.000 EA
421948044	LABEL, MYLAR	1.000 EA
034690001AB	1/8" NPT SQHDPLG	2.000 EA
004824015A	GREASE POLYREX EM	0.540 LB
032018008CK	HHCS 3/8-16X1L PLATED	4.000 EA
032018008CK	HHCS 3/8-16X1L PLATED	4.000 EA
032018020EK	HHCS 5/8-11X2-1/2 PLTD.	4.000 EA
032018024CK	HHCS 3/8-16X3 PLTD.	3.000 EA
034000014AB	WSH ID.406 OD.812 TH.065	4.000 EA
034180012DA	KEY 1X4X1/4X1-1/2 L	1.000 EA
034530052AB	P/NIP 1/8X6-1/2 GALV.	1.000 EA
034530056BB	P/NIP 1/4X7 SCHED 40	1.000 EA
034690001AB	1/8" NPT SQHDPLG	1.000 EA
083198127A	G400 MOLDED FAN COVER	1.000 EA
034692005AA	P PLUG 3/4"BLK.	1.000 EA
034631002AB	BUSH 1/4 TO 1/8 PLTD.	1.000 EA
089413501A	G400 FIN/MACH FT MTD BRKT 089413500WCA	1.000 EA
410700004F	WSHR	1.000 EA
415072001B	CLAMP	1.000 EA

Parts List (continued)		
Part Number	Description	Quantity
415096002A	CPLG 1/8 HEX TYPE	1.000 EA
702675001D	FAN 250-440	1.000 EA
032018020EK	HHCS 5/8-11X2-1/2 PLTD.	4.000 EA
032018024CK	HHCS 3/8-16X3 PLTD.	3.000 EA
034690002AB	PPLG 1/4" PLTD.	1.000 EA
089413501A	G400 FIN/MACH FT MTD BRKT 089413500WCA	1.000 EA
032018005AK	HHCS 1/4-20X5/8 PLATED	4.000 EA
033512004LB	HHTTS 1/4-20X1/2 PLTD.	1.000 EA
035000001A	ALFTG 1/8" 1610-BL	1.000 EA
035000001A	ALFTG 1/8" 1610-BL	1.000 EA
043292000AJ	GASK 320-400	1.000 EA
077176000L	C/BOX, 360-400	1.000 EA
077176001A	CBOXC, PAINTED 360-400	1.000 EA
402731001A	GASK 360-440	1.000 EA
406099000A	PLUG - FAN COVER 320-440	1.000 EA
415000103D	T/LUG #4AWG-1/0AWG W/HOLE FOR .250 BOLT	1.000 EA
418150003A	GREASE FITTING CAP	1.000 EA
MG1025Y17	WILKOFAS, 789.701, SUPER E PEARL GOLD	0.375 GA
418150003A	GREASE FITTING CAP	1.000 EA
033775004EA	DRSCR #6-1/4 304 S.S.	2.000 EA
034180022GA	KEY 1/2X1/2X2-3/4 L	1.000 EA
604797045	STD. 400 FRAME SKID	1.000 EA

<b>Accessories</b>		
<b>Part Number</b>	<b>Description</b>	<b>Multiplier</b>
089413502A	G400 STD C-FACE BRKT 6313 089416511WCA	P1
089412075B	D-FLANGE BRKT 400 089416085WCA	P1

S/O	FRAME	HP	TYPE	PHASE/ HERTZ	RPM	VOLTS
	405TS	100	P	3/60	3565	460
AMPS	DUTY	AMB °C/ INSUL	S.F.	NEMA DESIGN	CODE LETTER	ENCLOSURE
110	CONT	40/F	1.15	B	F	TEFC
E/S	ROTOR	TEST S.O.	TEST DATE	STATOR RES. @25 °C OHMS (BETWEEN LINES)		
596954	418142005PE	---	---	.0526		

**PERFORMANCE**

LOAD	HP	AMPERES	RPM	% POWER FACTOR	% EFFICIENCY
NO LOAD	0	25.6	3600	7.58	0
1/4	25.0	36.7	3591	69.7	91.7
2/4	50.0	57.7	3582	85.8	94.6
3/4	75.1	82.7	3572	89.3	95.1
4/4	100	110	3563	89.9	95.0
5/4	125	137	3552	90.2	94.5

**SPEED TORQUE**

	RPM	% TORQUE FULL LOAD	TORQUE LB.-FT.	AMPERES
LOCKED ROTOR	0	203	299	695
PULL UP	1545	182	269	632
BREAKDOWN	3408	256	377	387
FULL LOAD	3563	100	147	110

AMPERES SHOWN FOR 460 VOLT CONNECTION. IF OTHER CONNECTIONS ARE AVAILABLE, THE AMPERES WILL VARY INVERSELY WITH THE RATED VOLTAGE.

TYPICAL DATA  
 XE MOTOR-NEMA NOM. EFF. 95.0 %  
 GUARANTEED MIN. EFF. 94.1%

	DRAWN BY: JJHARRISON	AC MOTOR PERFORMANCE DATA	A40W G1270-R001
	CHECKED BY: W.L.SMITH APPROVED BY: W.L.SMITH DATE: 06/13/07		DATE ISSUED 08/01/18



REL.S.O.	405TS	RPM	3565	S.F.	1.15	ROTOR	418142005PE
FRAME	100	VOLTS	460	NEMA DESIGN	B	TEST S.O.	TYPICAL DATA
HP	100	AMPS	110	CODE LETTER	F	TEST DATE	--
TYPE	P	DUTY CONT		ENCLOSURE	TEFC	STATOR RES. @ 25°C	.0526
PHASE/HERTZ	3/60	AMB °C/INSUL	40/F	E/S	590954	OHMS (BETWEEN LINES)	

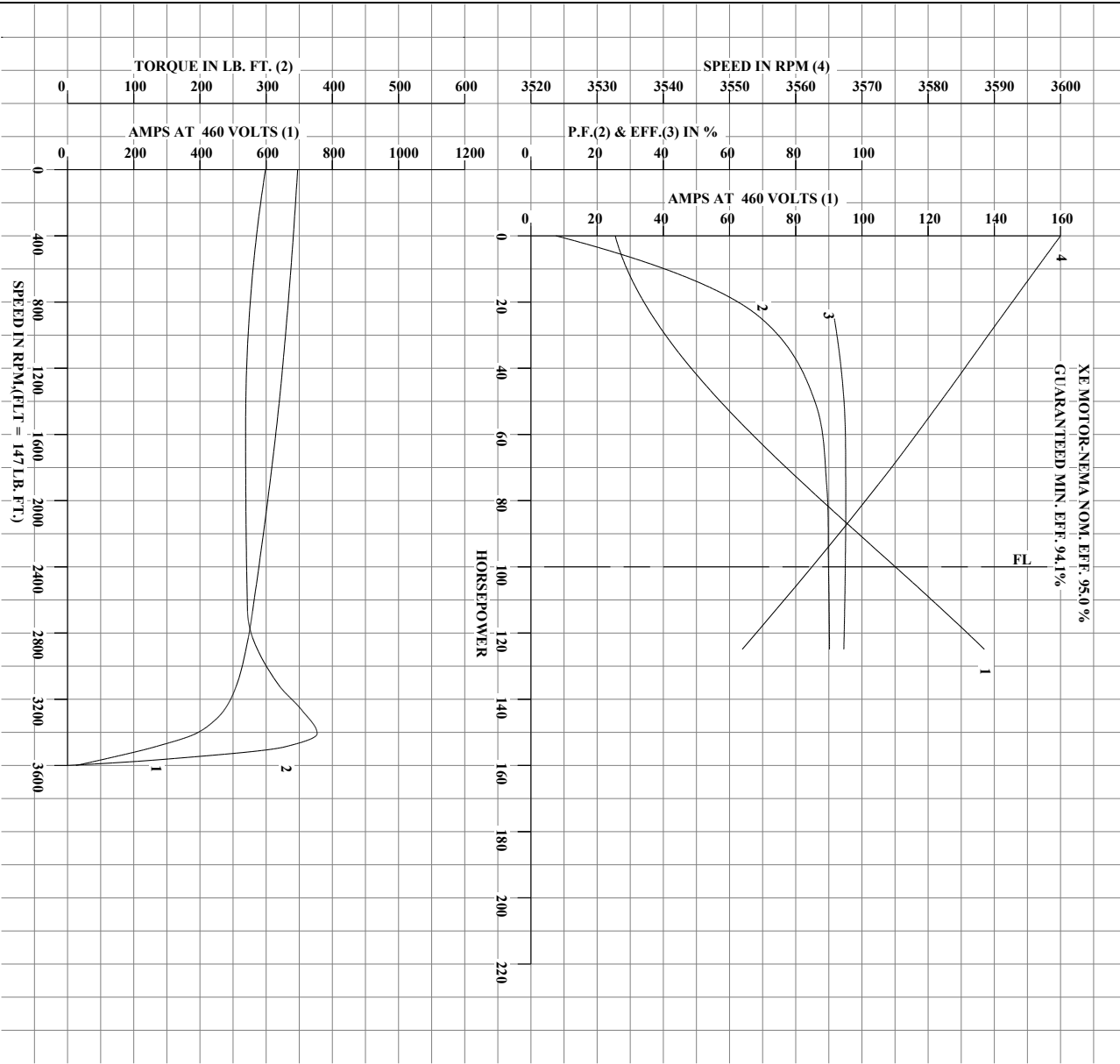

AMPERES SHOWN FOR 460 VOLT CONNECTION, IF OTHER VOLTAGE CONNECTIONS ARE AVAILABLE, THE AMPERES WILL VARY INVERSELY WITH THE RATED VOLTAGE.



DRAWN BY: J.J.HARRISON  
 CHECKED BY: W.L.SMITH  
 APPROVED BY: W.L.SMITH  
 DATE: 06/13/07

AC MOTOR  
 PERFORMANCE  
 DATA

A40WG1270-R001  
 ISSUE DATE: 08/01/18

US10TSA

Printed on 08/01/2018 9:25 AM

617429-002

## DUTY MASTER ALTERNATING CURRENT MOTORS

SQUIRREL-CAGE INDUCTION

ENCLOSURE: TOTALLY ENCLOSED

FRAME G405TS ABOVE NEMA RATINGS

COOLING: FAN COOLED

MOUNTING: FOOT

INCLUDES 404TS FRAME MOUNTING HOLES

STANDARD INDUSTRIAL ENCLOSURE

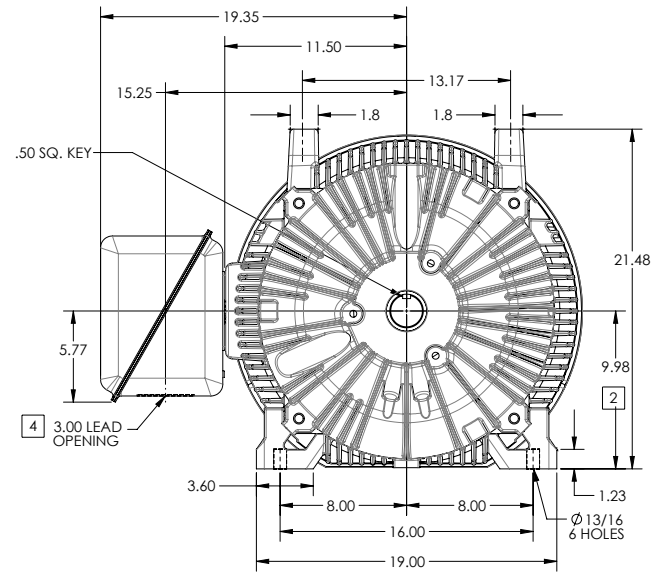
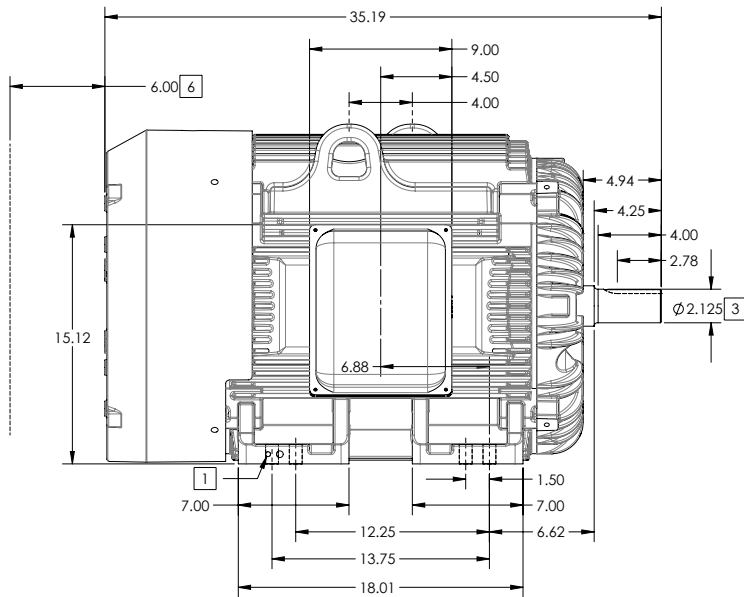

1. GROUND HOLES QTY 1 1/2-13 TAP; QTY 1 3/8-16 TAP
2. VARIES +.00,-.06
3. VARIES +.00,-.001
4. ON STANDARD MOTORS THIS IS CONDUIT SIZE. ON XT AND CORROSION PROOF MOTOR THIS IS PIPE TAP.
5. MOTOR WEIGHTS MAY VARY BY 15% DEPENDING ON RATING.
6. OBSTRUCTION MUST NOT ENCROACH ON AIR INLET

[5] WEIGHT (LBS): 1160

CONDUIT BOX LOCATED ON OPPOSITE SIDE WHEN F-2.  
IF MOUNTING CLEARANCE DETAILS ARE REQUIRED, CONSULT FACTORY.  
MAXIMUM PERMISSIBLE SHAFT RUNOUT WHEN MEASURED AT END OF STANDARD SHAFT EXTENSION IS .003" T.I.R. TO 5 INCH DIA.

DIMENSIONS ARE IN INCHES; SEE SHEET 2 FOR DIMENSIONS IN MILLIMETERS

CUSTOMER IS RESPONSIBLE FOR DETERMINING THAT MOTOR PERFORMANCE IS SUITABLE IN THE APPLICATION.

SHEET NUMBER  
1 OF 2

2007-6272119

REV. DESC: CHANGE BA FROM 6.76 TO 6.62	REVISED: 04/37/41 04/14/2014	TDR: 00000848770
REV: B	VERSION: 02	REF:
MODEL NO. 617429-002	BY: MGHMMZ	Material:

**BALDOR**

G405TS-404TS STD - FOOTED - STANDARD ENCLOSURE

617429-002

617429-002

## DUTY MASTER ALTERNATING CURRENT MOTORS

SQUIRREL-CAGE INDUCTION

ENCLOSURE: TOTALLY ENCLOSED

FRAME G405TS ABOVE NEMA RATINGS

COOLING: FAN COOLED

MOUNTING: FOOT

INCLUDES 404TS FRAME MOUNTING HOLES

STANDARD INDUSTRIAL ENCLOSURE

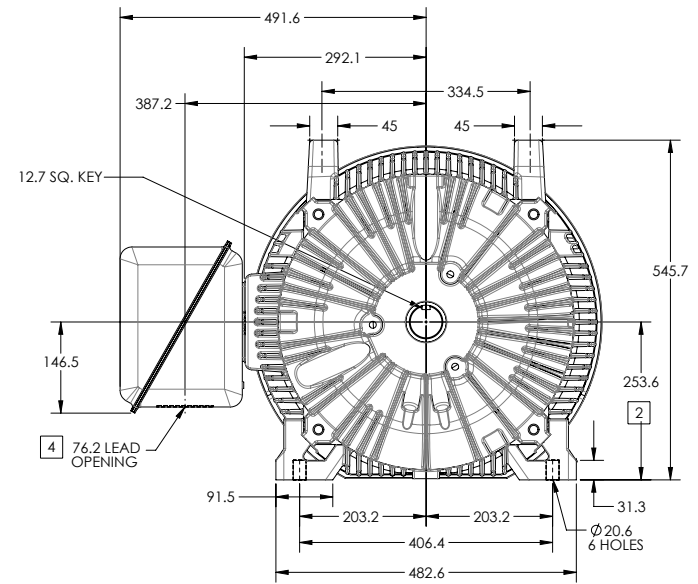
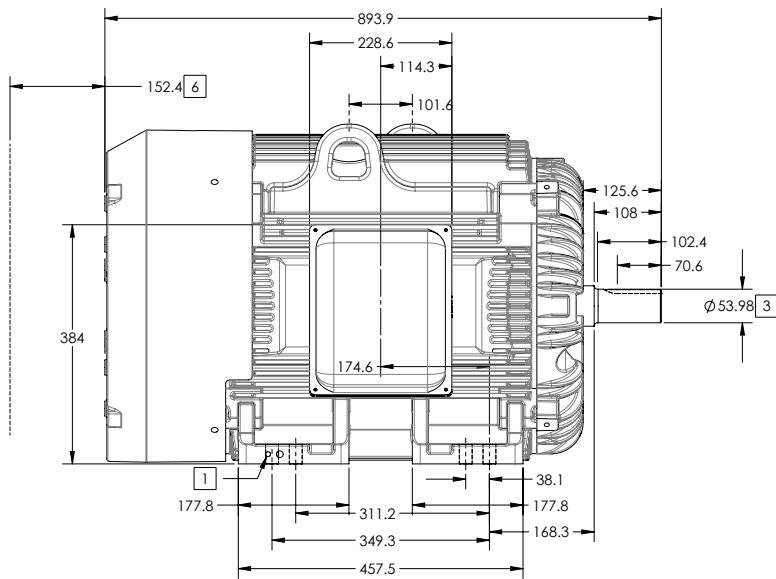

1. GROUND HOLES QTY 1 1/2-13 TAP; QTY 1 3/8-16 TAP
2. VARIES +0,-1.5
3. VARIES +00,-.03
4. ON STANDARD MOTORS THIS IS CONDUIT SIZE. ON XT AND CORROSION PROOF MOTOR THIS IS PIPE TAP.
5. MOTOR WEIGHTS MAY VARY BY 15% DEPENDING ON RATING.
6. OBSTRUCTION MUST NOT ENCROACH ON AIR INLET

[5] WEIGHT (KGS): 530

CONDUIT BOX LOCATED ON OPPOSITE SIDE WHEN F-2.  
IF MOUNTING CLEARANCE DETAILS ARE REQUIRED, CONSULT FACTORY.  
MAXIMUM PERMISSIBLE SHAFT RUNOUT WHEN MEASURED AT END OF STANDARD SHAFT EXTENSION IS .08 MM T.I.R. TO 127 MM DIA.

DIMENSIONS ARE IN MILLIMETERS; SEE SHEET 1 FOR DIMENSIONS IN INCHES

CUSTOMER IS RESPONSIBLE FOR DETERMINING THAT MOTOR PERFORMANCE IS SUITABLE IN THE APPLICATION.

SHEET NUMBER  
2 OF 2

Z00\*627219

REV. DESC: CHANGE BA FROM 6.76 TO 6.62	TDR: 00000848770
REV: B VERSION: 02 REVISED: 04/37/41 04/14/2014	REF:
MODEL NO. 617429-002	REF:
BY: MGHMMZ	Material:

**BALDOR**

G405TS-404TS STD - FOOTED - STANDARD ENCLOSURE

617429-002

416820-008

# A-C MOTOR CONNECTION DIAGRAM

STANDARD 6 LEAD

Y START - DELTA RUN

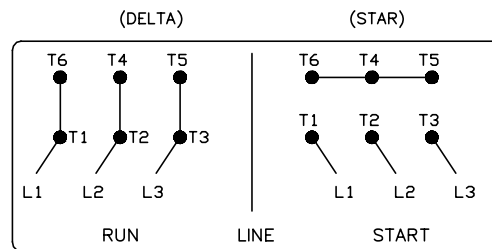
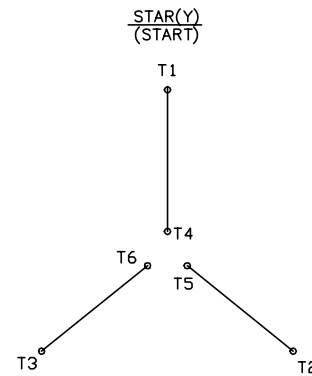
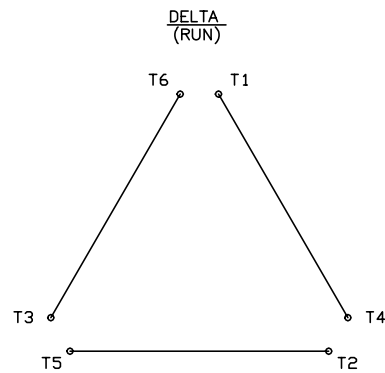

< N. P. 1767-DC >

REV. DESC: ADDED T4 TO Y CONNECT DIAGRAM		
REV. LTR: D	VERSION: 04	TDR: 000000847713
FILE: \RAG\00001\808	REVISED: 10: 41: 26 04/08/2014	BY: RAGJSS1
MTL: -	⊙ □	



CONNECT DIAGRAM STD 6 LEAD Y START DELTA RUN

SH 1 of 1

416820-008