

BALDOR® • RELIANCE 

Product Information Packet

FDEM2333T

15HP,1765RPM,3PH,60HZ,254T,0944M,TEFC,F1

Part Detail							
Revision:	M	Status:	PRD/A	Change #:		Proprietary:	No
Type:	AC	Elec. Spec:	09WGZ910	CD Diagram:	CD0005	Mfg Plant:	
Mech. Spec:	09K989	Layout:	09LYK989	Poles:	04	Created Date:	12-16-2013
Base:	RG	Eff. Date:	07-03-2018	Leads:	9#12		

Specs			
Catalog Number:	FDEM2333T	Heater Indicator:	No Heater
Enclosure:	TEFC	Insulation Class:	F
Frame:	254T	Inverter Code:	Inverter Ready
Frame Material:	Iron	KVA Code:	H
Output @ Frequency:	15.000 HP @ 60 HZ	Lifting Lugs:	Standard Lifting Lugs
Synchronous Speed @ Frequency:	1800 RPM @ 60 HZ	Locked Bearing Indicator:	Locked Bearing
Voltage @ Frequency:	460.0 V @ 60 HZ	Motor Lead Quantity/Wire Size:	9 @ 12 AWG
	230.0 V @ 60 HZ	Motor Lead Exit:	Ko Box
XP Class and Group:	None	Motor Lead Termination:	Flying Leads
XP Division:	Not Applicable	Motor Type:	0944M
Agency Approvals:	UR	Mounting Arrangement:	F1
	CSA EEV	Power Factor:	83
	CSA	Product Family:	General Purpose
Auxillary Box:	No Auxillary Box	Pulley End Bearing Type:	Sealed Bearing
Auxillary Box Lead Termination:	None	Pulley Face Code:	Standard
Base Indicator:	Rigid	Pulley Shaft Indicator:	Standard
Bearing Grease Type:	Polyrex EM (-20F +300F)	Rodent Screen:	None
Blower:	None	Shaft Extension Location:	Pulley End

Current @ Voltage:	18.100 A @ 460.0 V	Shaft Ground Indicator:	No Shaft Grounding
	36.200 A @ 230.0 V	Shaft Rotation:	Reversible
	38.000 A @ 208.0 V	Shaft Slinger Indicator:	Shaft Slinger
Design Code:	A	Speed Code:	Single Speed
Drip Cover:	No Drip Cover	Motor Standards:	NEMA
Duty Rating:	CONT	Starting Method:	Direct on line
Electrically Isolated Bearing:	Not Electrically Isolated	Thermal Device - Bearing:	None
Feedback Device:	NO FEEDBACK	Thermal Device - Winding:	None
Front Face Code:	Standard	Vibration Sensor Indicator:	No Vibration Sensor
Front Shaft Indicator:	None	Winding Thermal 1:	None
		Winding Thermal 2:	None

Nameplate NP3126L										
CAT.NO.	FDEM2333T									
SPEC.	09K989Z910G1									
HP	15									
VOLTS	230/460									
AMP	36.2/18.1									
RPM	1765									
FRAME	254T				HZ	60			PH	3
SER.F.	1.15		CODE	H	DES	A		CL	F	
NEMA-NOM-EFF	92.4		PF	83						
RATING	40C AMB-CONT									
CC	010A				USABLE AT 208V			38		
DE	6309				ODE	6208				
ENCL	TEFC		SN							

Parts List		
Part Number	Description	Quantity
SA274091	SA 09K989Z910G1	1.000 EA
RA260679	RA 09K989Z910G1	1.000 EA
09CB3002SP	CB W/1.38 LEAD HOLE FOR 37, 39, 307 & 30	1.000 EA
09GS1000SP	GASKET-CONDUIT BOX, 1/16 THICK LEXIDE	1.000 EA
10XN2520K12	1/4-20 X.75 GRD 5	2.000 EA
HW1001A25	LOCKWASHER 1/4, ZINC PLT .493 OD, .255 I	2.000 EA
WD1000B16	T&B CX70TN TERMINAL	1.000 EA
59XW2520G07	.25-20X.44,HEX SER WSHR,TAPTITE 2,GREEN	1.000 EA
09EP1100A198	ENDPLATE, MACH	1.000 EA
XY3816A12	3/8-16 FINISHED NUT	4.000 EA
HW1001A38	LOCKWASHER 3/8, ZINC PLT .688 OD, .382 I	4.000 EA
09FH1000	BALDOR MOTOR FAN COVER	1.000 EA
09CB3501SP	CONDUIT BOX LID FOR 09CB3001 & 09CB3002	1.000 EA
09GS1013SP	09 GS FOR 09CB3501 LID - LEXIDE	1.000 EA
HW5100A08	W3118-035 WVY WSHR (WB)	1.000 EA
09EP1101A144	PU ENDPLATE, MACH W/NO GREASER HOLES	1.000 EA
HW4600B44	V-RING SLINGER 1.500 X 1.810 X .28 VITON	1.000 EA
HW4600A51	SEAL 1.688 X 2.686 X 0.313 SINGLE LIP-CR	1.000 EA
10XN2520K36	1/4-20 X 2.25" HX HD SCRWGRADE 5, ZINC P	4.000 EA
HW1001A25	LOCKWASHER 1/4, ZINC PLT .493 OD, .255 I	4.000 EA
HA3113A05	THRUBOLT 3/8 - 16 X 17.250	4.000 EA
HW1001A38	LOCKWASHER 3/8, ZINC PLT .688 OD, .382 I	4.000 EA
HA2081A05	SPACER TUBE, 309 FAN HSG, 2.00 LONG	4.000 EA
XY3816A12	3/8-16 FINISHED NUT	4.000 EA

Parts List (continued)		
Part Number	Description	Quantity
HW1001A38	LOCKWASHER 3/8, ZINC PLT .688 OD, .382 I	4.000 EA
51XW2520A12	.25-20 X .75, TAPTITE II, HEX WSHR SLTD	2.000 EA
HW2501G25	KEY, 3/8 SQ X 2.875	1.000 EA
LB1115N	LABEL,LIFTING DEVICE (ON ROLLS)	1.000 EA
MN416A01	TAG-INSTAL-MAINT no wire (1200/bx) 5/18	1.000 EA
HA4066A01	PUSH IN T-DRAIN FITTING (BLACK)	1.000 EA
MJ1000A02	GREASE, POLYREX EM EXXON (USe 4824-15A)	0.080 LB
HA4066A01	PUSH IN T-DRAIN FITTING (BLACK)	1.000 EA
09FN3001D01SP	EXTERNAL FAN, PLASTIC	1.000 EA
HW2500A25	WOODRUFF KEY USA #1008 #BLOW CARBON STEE	1.000 EA
51XB1214A20	12-14X1.25 HXWSSLD SERTYB	1.000 EA
MG1025C02	WILKOFASST SG, 787.105, TAN	0.050 GA
85XU0407S04	4X1/4 U DRIVE PIN STAINLESS	2.000 EA
LB1119N	WARNING LABEL	1.000 EA
LC0005	CONN.DIA.,TY M,9-LD,DUAL VOLT,REVERSING	1.000 EA
NP3126L	ALUM FARM DUTY SUPER-E UL CSA-EEV PREM	1.000 EA
09PA1000	PACKAGING GROUP COMBINED PRINT	1.000 EA
PE-0000003	ZRTG PE ASSEMBLY	1.000 EA

AC Induction Motor Performance Data

Record # 40347 - Typical performance - not guaranteed values

Winding: 09WGZ910-R001	Type: 0944M	Enclosure: TEFC
-------------------------------	--------------------	------------------------

Nameplate Data				460 V, 60 Hz: High Voltage Connection	
Rated Output (HP)	15			Full Load Torque	44.5 LB-FT
Volts	230/460			Start Configuration	direct on line
Full Load Amps	36.2/18.1			Breakdown Torque	153 LB-FT
R.P.M.	1765			Pull-up Torque	69.5 LB-FT
Hz	60	Phase	3	Locked-rotor Torque	86.5 LB-FT
NEMA Design Code	A	KVA Code	H	Starting Current	127 A
Service Factor (S.F.)	1.15			No-load Current	7.56 A
NEMA Nom. Eff.	92.4	Power Factor	83	Line-line Res. @ 25°C	0.59555 Ω
Rating - Duty	40C AMB-CONT			Temp. Rise @ Rated Load	54°C
S.F. Amps				Temp. Rise @ S.F. Load	67°C
				Locked-rotor Power Factor	33.1
				Rotor inertia	1.92 LB-FT ²

Load Characteristics 460 V, 60 Hz, 15 HP

% of Rated Load	25	50	75	100	125	150	S.F.
Power Factor	45	69	79	83	85	87	84
Efficiency	88.2	92.2	92.7	92.4	91.5	90.4	91.9
Speed	1791.3	1783.1	1774	1765.2	1754.6	1743.1	1759
Line amperes	8.62	11	14.5	18.1	22.6	26.9	20.8

Performance Graph at 460V, 60Hz, 15.0HP Typical performance - Not guaranteed values

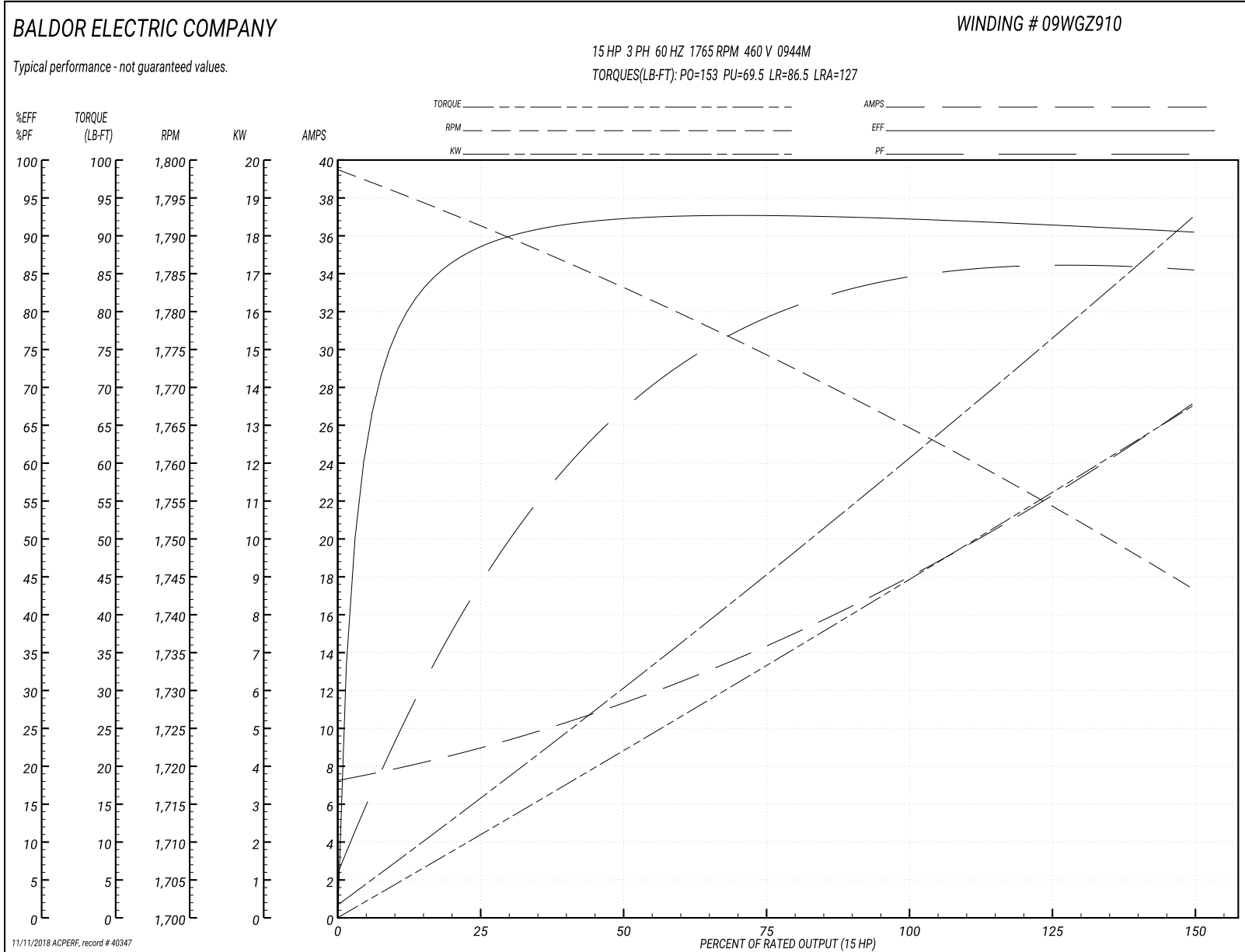

09LYK989

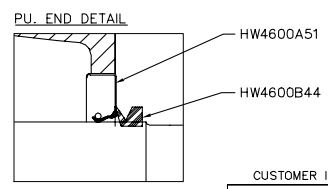
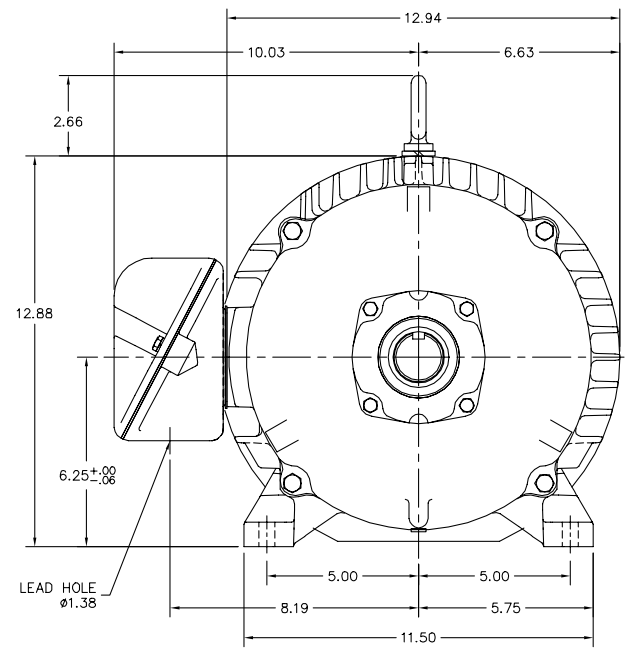
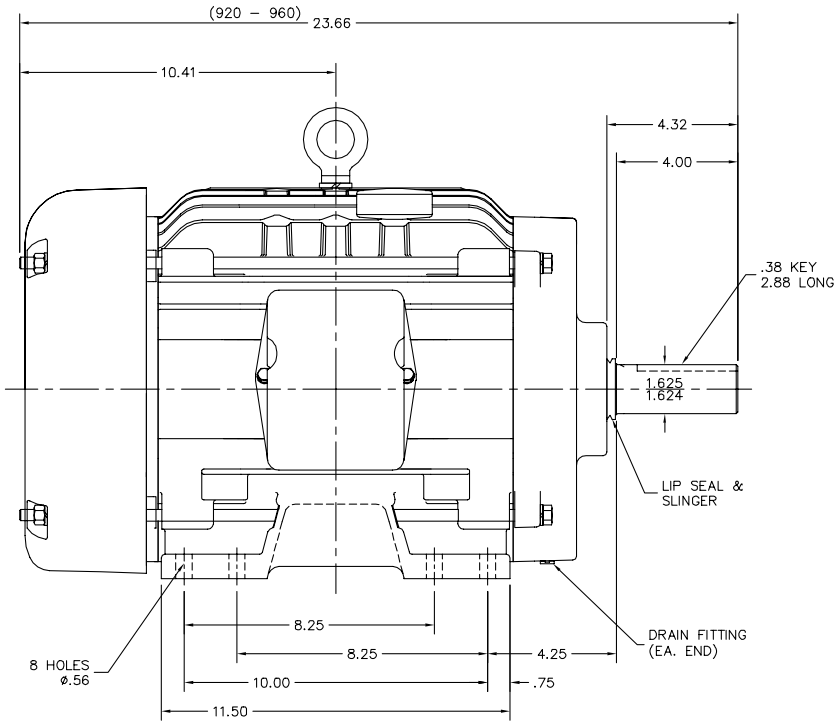

CUSTOMER IS RESPONSIBLE FOR DETERMINING THAT BALDOR'S PRODUCT WILL PERFORM SUITABLY IN THE INTENDED APPLICATION.

REV. DESC: CHG'D TO 60 STACK MAX		
REV. LTR: D	VERSION: 04	TDR: 000001051765
FILE: \AAA\00205\471	REVISED: 03:47:50 11/20/2017	BY: ENBRIRO
MTL: -		

BALDOR

HORZ TEFC 254-6T W/SLD BRGS, LIP SEAL & SLINGER (FARM DUTY)

SH 1 of 1

09LYK989

CD0005



LOW VOLTAGE
(2Y)

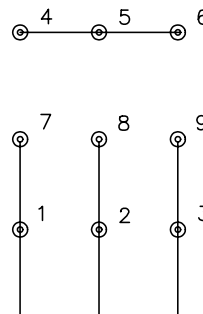

LINE

HIGH VOLTAGE
(1Y)

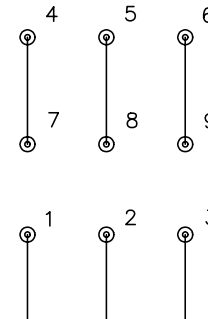

LINE

NOTES:

1. INTERCHANGE ANY TWO LINE LEADS TO REVERSE ROTATION.
2. OPTIONAL THERMOSTATS ARE PROVIDED WHEN SPECIFIED.
3. ACTUAL NUMBER OF INTERNAL PARALLEL CIRCUITS MAY BE A MULTIPLE OF THOSE SHOWN ABOVE.
4. LEAD COLORS ARE OPTIONAL. LEADS MUST ALWAYS BE NUMBERED AS SHOWN.

REV. DESC: REVISE TO SHOW OPTIONAL COLORS			
REV. LTR: E	BY: JLP	REVISED: 01/19/99 10:15	TDR: 0171435
90000		FILE: AAA00005140	MDL: -
		MTL: -	

BALDOR ELECTRIC Co.

3PH, DV, 9 LEADS

CD0005

Marketing maintained PDF of MN416:

<http://www.baldor.com/support/Literature/Load.ashx/MN416?ManNumber=MN416>