

BALDOR® • RELIANCE 

Product Information Packet

FDEM4107T

44M 2P TEFC HOR 284TS FARM DUTY SE

Part Detail							
Revision:	-	Status:	PRD/A	Change #:		Proprietary:	No
Type:	AC	Elec. Spec:	09WGT577	CD Diagram:	CD0005	Mfg Plant:	
Mech. Spec:	09L813	Layout:	09LYL813	Poles:	02	Created Date:	09-29-2018
Base:	RG	Eff. Date:	10-02-2018	Leads:	9#10		

Specs			
Catalog Number:	FDEM4107T	Heater Indicator:	No Heater
Enclosure:	TEFC	Insulation Class:	F
Frame:	284TS	Inverter Code:	Inverter Ready
Frame Material:	Iron	KVA Code:	J
Output @ Frequency:	25.000 HP @ 60 HZ	Lifting Lugs:	Standard Lifting Lugs
Synchronous Speed @ Frequency:	3600 RPM @ 60 HZ	Locked Bearing Indicator:	Locked Bearing
Voltage @ Frequency:	460.0 V @ 60 HZ	Motor Lead Quantity/Wire Size:	9 @ 10 AWG
	230.0 V @ 60 HZ	Motor Lead Exit:	Ko Box
XP Class and Group:	None	Motor Lead Termination:	Flying Leads
XP Division:	Not Applicable	Motor Type:	0944M
Agency Approvals:	UR	Mounting Arrangement:	F1
	CSA EEV	Power Factor:	88
	CSA	Product Family:	General Purpose
Auxillary Box:	No Auxillary Box	Pulley End Bearing Type:	Ball
Auxillary Box Lead Termination:	None	Pulley Face Code:	Standard
Base Indicator:	Rigid	Pulley Shaft Indicator:	Standard
Bearing Grease Type:	Polyrex EM (-20F +300F)	Rodent Screen:	None
Blower:	None	Shaft Extension Location:	Pulley End

Current @ Voltage:	29.000 A @ 460.0 V	Shaft Ground Indicator:	No Shaft Grounding
	58.000 A @ 230.0 V	Shaft Rotation:	Reversible
	62.000 A @ 208.0 V	Shaft Slinger Indicator:	Shaft Slinger
Design Code:	A	Speed Code:	Single Speed
Drip Cover:	No Drip Cover	Motor Standards:	NEMA
Duty Rating:	CONT	Starting Method:	Direct on line
Electrically Isolated Bearing:	Not Electrically Isolated	Thermal Device - Bearing:	None
Feedback Device:	NO FEEDBACK	Thermal Device - Winding:	None
Front Face Code:	Standard	Vibration Sensor Indicator:	No Vibration Sensor
Front Shaft Indicator:	None	Winding Thermal 1:	None
		Winding Thermal 2:	None

Nameplate NP3126L										
CAT.NO.	FDEM4107T									
SPEC.	09L813T577G1									
HP	25									
VOLTS	230/460									
AMP	58/29									
RPM	3520									
FRAME	284TS				HZ	60			PH	3
SER.F.	1.15		CODE	J	DES	A		CL	F	
NEMA-NOM-EFF	91.7		PF	88						
RATING	40C AMB-CONT									
CC	010A				USABLE AT 208V			62		
DE	6311				ODE	6208				
ENCL	TEFC		SN							

Parts List		
Part Number	Description	Quantity
SA361321	SA 09L813T577G1	1.000 EA
RA350505	RA 09L813T577G1	1.000 EA
37FN3002B02	EXFN, PLASTIC, 7.50 OD, 1.503 ID	1.000 EA
HW1002A63	0ASHER, 5/8 HI-COLLAR SPRLCKWASHER	1.000 EA
10CB3000SP	STD KO BOX MODEL 310,312,314 MTRS W/2.00	1.000 EA
12GS1000SP	GASKET	1.000 EA
10XN3118K12	5/16-18 X .75 GRADE 5, ZINC PLATED	4.000 EA
HW1001A31	LOCKWASHER 5/16, ZINC PLT.591 OD, .319 I	4.000 EA
WD1000B25	GND LUG, BURNDY L125HP OR T&B L125HP-BB	1.000 EA
19XW3118G08	.31-18X.50,HEX WSHR HD,TAPTITE 2,GREEN	1.000 EA
09EP1100A198	ENDPLATE, MACH	1.000 EA
XY3816A12	3/8-16 FINISHED NUT	4.000 EA
HW1001A38	LOCKWASHER 3/8, ZINC PLT .688 OD, .382 I	4.000 EA
HW4600B44	V-RING SLINGER 1.500 X 1.810 X .28 VITON	1.000 EA
HW5100A08	W3118-035 WVY WSHR (WB)	1.000 EA
10XN3118K40	5/16-18 X 2.50" HEX HD, GRADE 5	4.000 EA
HW1001A31	LOCKWASHER 5/16, ZINC PLT.591 OD, .319 I	4.000 EA
09EP1116A33	PU ENDPLATE, MACH FOR LIP SEAL,"O" DRAIN	1.000 EA
HW4600A53	SEAL 2.00 X 3.00 X 0.313 SINGLE LIP	1.000 EA
HW4600B40	V-RING SLINGER 2.000 X 2.680 X .28 VITON	1.000 EA
HA3113A15	THRUBOLT 3/8-16 X 18.875 W/3.50 THD LENG	4.000 EA
HW1001A38	LOCKWASHER 3/8, ZINC PLT .688 OD, .382 I	4.000 EA
09FH4000SP	309 FH	1.000 EA
HA2081A05	SPACER TUBE, 309 FAN HSG, 2.00 LONG	4.000 EA

Parts List (continued)		
Part Number	Description	Quantity
XY3816A12	3/8-16 FINISHED NUT	4.000 EA
HW1001A38	LOCKWASHER 3/8, ZINC PLT .688 OD, .382 I	4.000 EA
10CB3500SP	CONDUIT BOX LID, CAST	1.000 EA
10GS1000SP	GASKET, CONDUIT BOX LID	1.000 EA
51XW2520A12	.25-20 X .75, TAPTITE II, HEX WSHR SLTD	4.000 EA
HW2501G17	KEY, 3/8 SQ X 1.875	1.000 EA
LB1115N	LABEL,LIFTING DEVICE (ON ROLLS)	1.000 EA
HA4066A01	PUSH IN T-DRAIN FITTING (BLACK)	1.000 EA
MJ1000A02	GREASE, POLYREX EM EXXON (USe 4824-15A)	0.080 LB
HA4066A01	PUSH IN T-DRAIN FITTING (BLACK)	1.000 EA
HW2500A25	WOODRUFF KEY USA #1008 #BLOW CARBON STEE	1.000 EA
51XB1214A20	12-14X1.25 HXWSSLD SERTYB	1.000 EA
MG1025C02	WILKOFASST SG, 787.105, TAN	0.050 GA
85XU0407S04	4X1/4 U DRIVE PIN STAINLESS	2.000 EA
LB1119N	WARNING LABEL	1.000 EA
LC0005	CONN.DIA.,TY M,9-LD,DUAL VOLT,REVERSING	1.000 EA
NP3126L	ALUM FARM DUTY SUPER-E UL CSA-EEV PREM	1.000 EA
40PA1005	PACKAGING GROUP, 09 STD	1.000 EA
MN416A01	TAG-INSTAL-MAINT no wire (1200/bx) 5/18	1.000 EA

AC Induction Motor Performance Data

Record # 72672 - Typical performance - not guaranteed values

Winding: 09WGT577-R001	Type: 0944M	Enclosure: TEFC
-------------------------------	--------------------	------------------------

Nameplate Data				460 V, 60 Hz: High Voltage Connection	
Rated Output (HP)	25			Full Load Torque	37.39 LB-FT
Volts	230/460			Start Configuration	direct on line
Full Load Amps	58/29			Breakdown Torque	153 LB-FT
R.P.M.	3520			Pull-up Torque	58.5 LB-FT
Hz	60	Phase	3	Locked-rotor Torque	75 LB-FT
NEMA Design Code	A	KVA Code	J	Starting Current	223 A
Service Factor (S.F.)	1.15			No-load Current	10.1 A
NEMA Nom. Eff.	91.7	Power Factor	88	Line-line Res. @ 25°C	0.3381 Ω
Rating - Duty	40C AMB-CONT			Temp. Rise @ Rated Load	74°C
S.F. Amps				Temp. Rise @ S.F. Load	91°C
				Locked-rotor Power Factor	29.7

Load Characteristics 460 V, 60 Hz, 25 HP

% of Rated Load	25	50	75	100	125	150	S.F.
Power Factor	55	76	84	88	89	90	89
Efficiency	87.6	91.6	92.2	91.8	90.9	89.8	91.3
Speed	3580.5	3562.7	3544.2	3524	3501.4	3477.9	3510
Line amperes	12.3	16.9	22.7	29.1	36.1	43.5	33.3

Performance Graph at 460V, 60Hz, 25.0HP Typical performance - Not guaranteed values

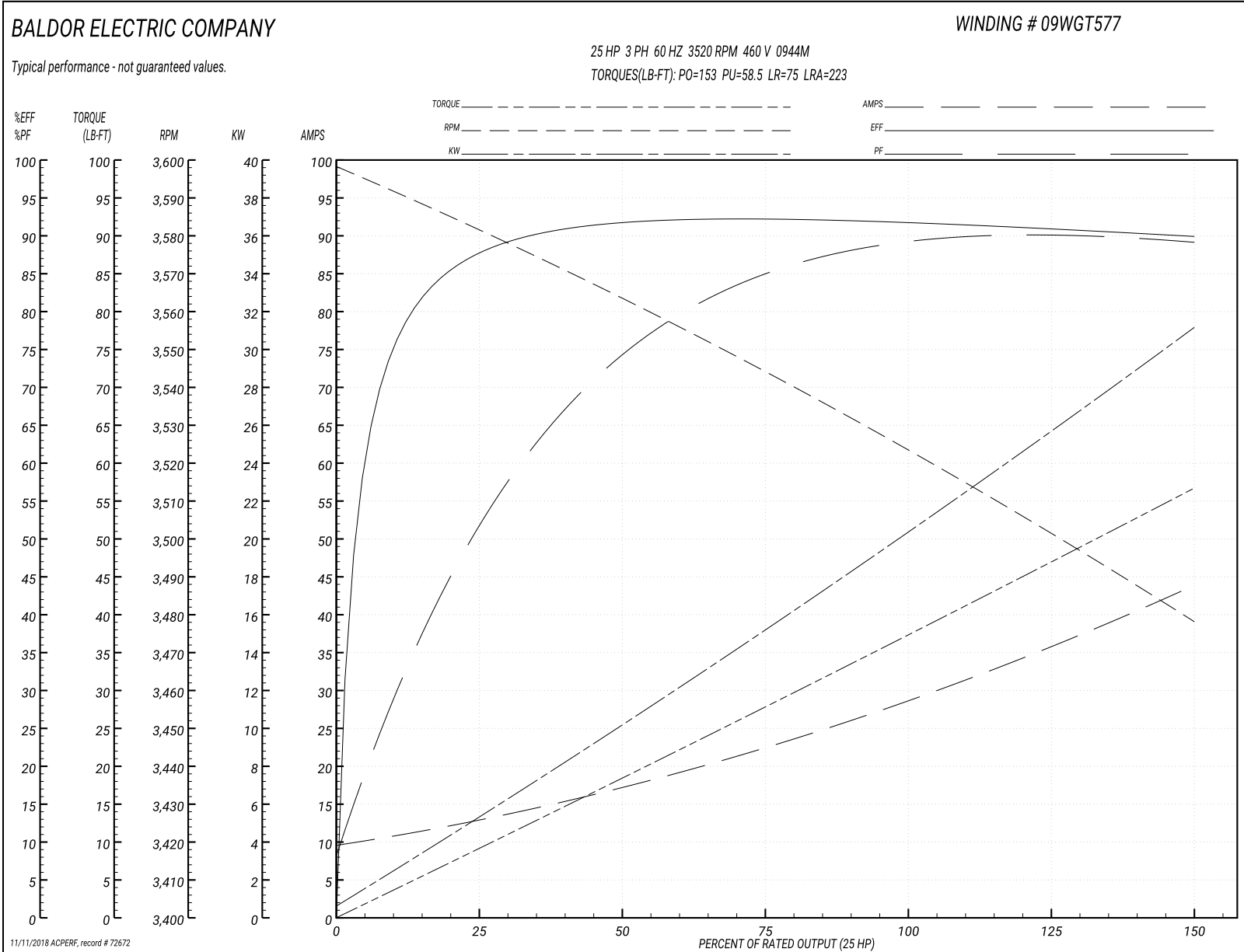

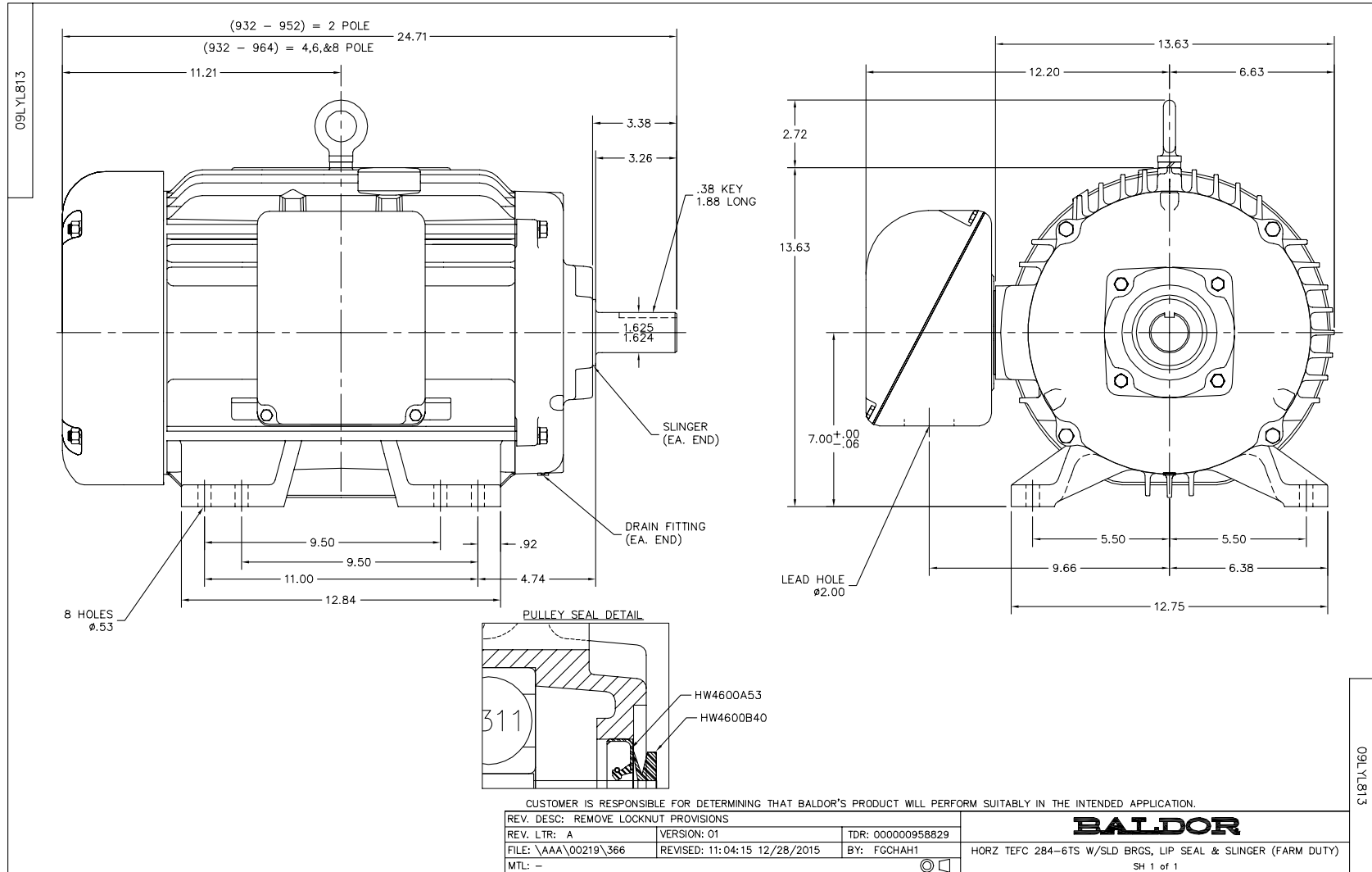

CD0005



LOW VOLTAGE (2Y)



HIGH VOLTAGE (1Y)

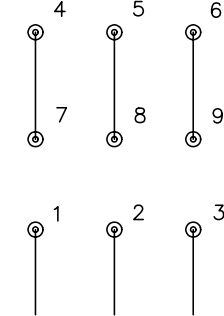

NOTES:

1. INTERCHANGE ANY TWO LINE LEADS TO REVERSE ROTATION.
2. OPTIONAL THERMOSTATS ARE PROVIDED WHEN SPECIFIED.
3. ACTUAL NUMBER OF INTERNAL PARALLEL CIRCUITS MAY BE A MULTIPLE OF THOSE SHOWN ABOVE.
4. LEAD COLORS ARE OPTIONAL. LEADS MUST ALWAYS BE NUMBERED AS SHOWN.

REV. DESC: REVISE TO SHOW OPTIONAL COLORS			
REV. LTR: E	BY: JLP	REVISED: 01/19/99 10:15	TDR: 0171435
90000		FILE: AAA00005140	MDL: -
		MTL: -	

BALDOR ELECTRIC Co.

3PH, DV, 9 LEADS

CD0005

Marketing maintained PDF of MN416:

<http://www.baldor.com/support/Literature/Load.ashx/MN416?ManNumber=MN416>