

BALDOR® • RELIANCE 

Product Information Packet

FDEM4109T

40HP,3530RPM,3PH,60HZ,324TS,1058M,TEFC,F

Part Detail							
Revision:	-	Status:	PRD/A	Change #:		Proprietary:	No
Type:	AC	Elec. Spec:	10WGY652	CD Diagram:	CD0180	Mfg Plant:	
Mech. Spec:	10L267	Layout:	10LYL267	Poles:	02	Created Date:	06-19-2018
Base:	RG	Eff. Date:	06-20-2018	Leads:	9#8		

Specs			
Catalog Number:	FDEM4109T	Heater Indicator:	No Heater
Enclosure:	TEFC	Insulation Class:	F
Frame:	324TS	Inverter Code:	Inverter Ready
Frame Material:	Iron	KVA Code:	H
Output @ Frequency:	40.000 HP @ 60 HZ	Lifting Lugs:	Standard Lifting Lugs
Synchronous Speed @ Frequency:	3600 RPM @ 60 HZ	Locked Bearing Indicator:	Locked Bearing
Voltage @ Frequency:	460.0 V @ 60 HZ	Motor Lead Quantity/Wire Size:	9 @ 8 AWG
	230.0 V @ 60 HZ	Motor Lead Exit:	Ko Box
XP Class and Group:	None	Motor Lead Termination:	Flying Leads
XP Division:	Not Applicable	Motor Type:	1058M
Agency Approvals:	UR	Mounting Arrangement:	F1
	CSA EEV	Power Factor:	90
	CSA	Product Family:	General Purpose
Auxillary Box:	No Auxillary Box	Pulley End Bearing Type:	Sealed Bearing
Auxillary Box Lead Termination:	None	Pulley Face Code:	Standard
Base Indicator:	Rigid	Pulley Shaft Indicator:	Standard
Bearing Grease Type:	Polyrex EM (-20F +300F)	Rodent Screen:	None
Blower:	None	Shaft Extension Location:	Pulley End

Current @ Voltage:	100.000 A @ 208.0 V	Shaft Ground Indicator:	No Shaft Grounding
	45.000 A @ 460.0 V	Shaft Rotation:	Reversible
	90.000 A @ 230.0 V	Shaft Slinger Indicator:	Shaft Slinger
Design Code:	A	Speed Code:	Single Speed
Drip Cover:	No Drip Cover	Motor Standards:	NEMA
Duty Rating:	CONT	Starting Method:	Direct on line
Electrically Isolated Bearing:	Not Electrically Isolated	Thermal Device - Bearing:	NONE (OLD)
Feedback Device:	NO FEEDBACK	Thermal Device - Winding:	None
Front Face Code:	Standard	Vibration Sensor Indicator:	No Vibration Sensor
Front Shaft Indicator:	None	Winding Thermal 1:	None
		Winding Thermal 2:	None

Nameplate NP3126L										
CAT.NO.	FDEM4109T									
SPEC.	10L267Y652G1									
HP	40									
VOLTS	230/460									
AMP	90/45									
RPM	3530									
FRAME	324TS				HZ	60			PH	3
SER.F.	1.15		CODE	H	DES	A		CL	F	
NEMA-NOM-EFF	92.4		PF	90						
RATING	40C AMB-CONT									
CC	010A				USABLE AT 208V			100		
DE	6312			ODE	6309					
ENCL	TEFC		SN							

Parts List		
Part Number	Description	Quantity
SA357283	SA 10L267Y652G1	1.000 EA
RA346267	RA 10L267Y652G1	1.000 EA
37FN3002C03	EXFN, PLASTIC, 6.00 OD, 1.690 ID	1.000 EA
10CB3000A05	CONDUIT BOX MACH. W/ 2.00" NPT LEAD HOLE	1.000 EA
12GS1000SP	GASKET	1.000 EA
10XN3118K12	5/16-18 X .75 GRADE 5, ZINC PLATED	4.000 EA
HW1001A31	LOCKWASHER 5/16, ZINC PLT.591 OD, .319 I	4.000 EA
WD1000B25	GND LUG, BURNDY L125HP OR T&B L125HP-BB	1.000 EA
19XW3118G08	.31-18X.50,HEX WSHR HD,TAPTITE 2,GREEN	1.000 EA
10EP1106A79	FREP MACH W/O GREASERS, W/"O" DRAINS	1.000 EA
10XN3816K32	BOLT, 3/8-16X2 HH YZ(5)	4.000 EA
HW1001A38	LOCKWASHER 3/8, ZINC PLT .688 OD, .382 I	4.000 EA
HW4600B67	V-RING SLINGER 1.770 X 2.170 X .28 VITON	1.000 EA
HW5100A11	W3917-042 WVY WSHR (WB)	1.000 EA
10EP1108A23	PUEP 312 BRG W/O GRSR, W/LIP & SLING."O"	1.000 EA
10XN3816K28	3/8-16 X 1.75 HEX HD CAP SCREW, GRADE 5	4.000 EA
HW1001A38	LOCKWASHER 3/8, ZINC PLT .688 OD, .382 I	4.000 EA
HW4600B34	SINGLE LIP SEAL 2.250 X 2.997 X .438,DBL	1.000 EA
HW4600B41	V-RING SLINGER 2.125 X 2.880 X 0.280	1.000 EA
10XN3118K44	5/16-18 X 2.75" HEX HD, GRADE 5	4.000 EA
10FH4000	310 FAN HOUSING STAMPED	1.000 EA
10XN2520K08	1/4-20 X .50 GRADE #5, STL, ZINC PLATE	4.000 EA
HW1001A25	LOCKWASHER 1/4, ZINC PLT .493 OD, .255 I	4.000 EA
10CB3500SP	CONDUIT BOX LID, CAST	1.000 EA

Parts List (continued)		
Part Number	Description	Quantity
10GS1000SP	GASKET, CONDUIT BOX LID	1.000 EA
51XW2520A12	.25-20 X .75, TAPTITE II, HEX WSHR SLTD	4.000 EA
HW2501H18	KEY, 1/2 SQ X 2.000	1.000 EA
LB1115N	LABEL,LIFTING DEVICE (ON ROLLS)	1.000 EA
HA4066A01	PUSH IN T-DRAIN FITTING (BLACK)	1.000 EA
MJ1000A02	GREASE, POLYREX EM EXXON (USe 4824-15A)	0.130 LB
HA4066A01	PUSH IN T-DRAIN FITTING (BLACK)	1.000 EA
HW2500A25	WOODRUFF KEY USA #1008 #BLOW CARBON STEE	1.000 EA
51XB1214A20	12-14X1.25 HXWSSLD SERTYB	1.000 EA
MG1025C02	WILKOFASST SG, 787.105, TAN	0.125 GA
85XU0407S04	4X1/4 U DRIVE PIN STAINLESS	2.000 EA
LB1119N	WARNING LABEL	1.000 EA
LC0181	CONNECTION LABEL	1.000 EA
NP3126L	ALUM FARM DUTY SUPER-E UL CSA-EEV PREM	1.000 EA
12PA1000	PACKAGING GROUP PRINT PK1024A06	1.000 EA
MN416A01	TAG-INSTAL-MAINT no wire (1200/bx) 5/18	1.000 EA

AC Induction Motor Performance Data

Record # 30898 - Typical performance - not guaranteed values

Winding: 10WGY652-R001	Type: 1058M	Enclosure: TEFC
-------------------------------	--------------------	------------------------

Nameplate Data				460 V, 60 Hz: High Voltage Connection	
Rated Output (HP)	40			Full Load Torque	59.5 LB-FT
Volts	230/460			Start Configuration	direct on line
Full Load Amps	90/45			Breakdown Torque	197 LB-FT
R.P.M.	3525			Pull-up Torque	85.4 LB-FT
Hz	60	Phase	3	Locked-rotor Torque	125 LB-FT
NEMA Design Code	B	KVA Code	H	Starting Current	324 A
Service Factor (S.F.)	1.15			No-load Current	12 A
NEMA Nom. Eff.	92.4	Power Factor	90	Line-line Res. @ 25°C	0.14992 Ω
Rating - Duty	40C AMB-CONT			Temp. Rise @ Rated Load	78°C
S.F. Amps				Temp. Rise @ S.F. Load	97°C
				Locked-rotor Power Factor	23
				Rotor inertia	2.49 LB-FT ²

Load Characteristics 460 V, 60 Hz, 40 HP

% of Rated Load	25	50	75	100	125	150	S.F.
Power Factor	65	82	88	90	90	91	90
Efficiency	90.7	93.4	93.7	93.2	92.4	91.1	92.7
Speed	3583.2	3567.3	3549.7	3530.6	3511.2	3484.5	3519
Line amperes	16.3	24.7	34.3	45.1	56.3	70.6	51.8

Performance Graph at 460V, 60Hz, 40.0HP Typical performance - Not guaranteed values

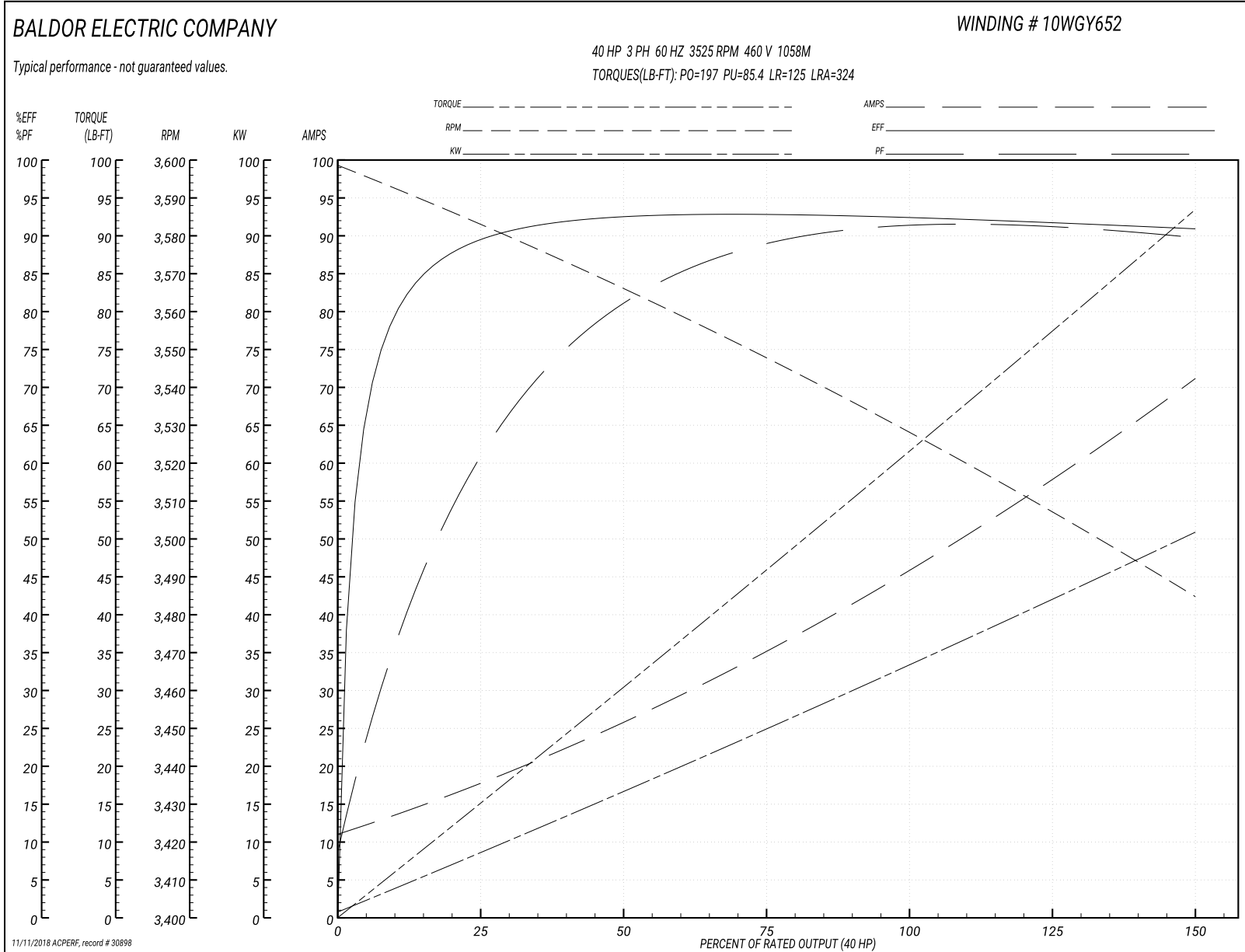

10LY1267

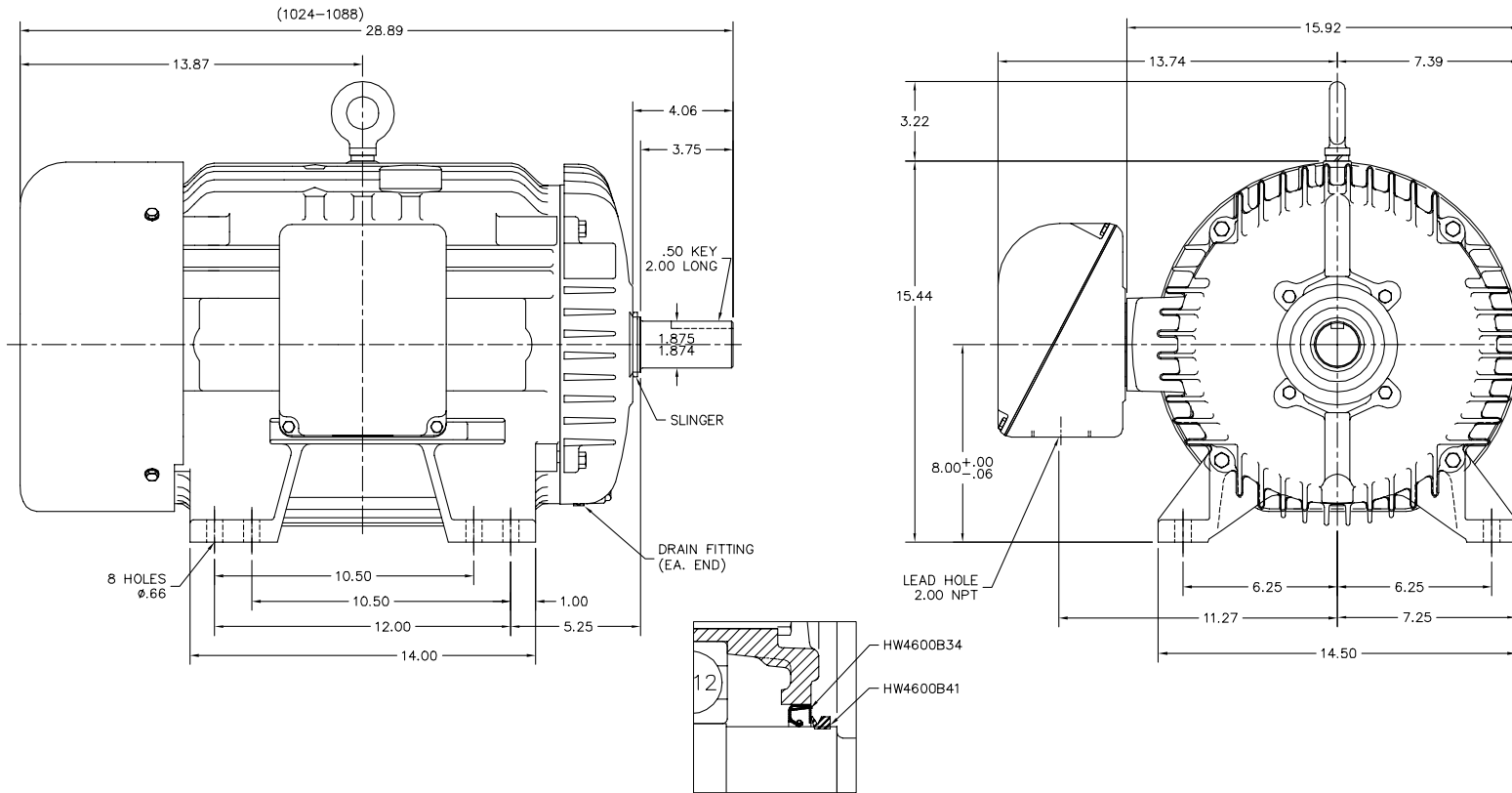

10LY1267

CUSTOMER IS RESPONSIBLE FOR DETERMINING THAT BALDOR'S PRODUCT WILL PERFORM SUITABLY IN THE INTENDED APPLICATION.

REV. DESC: NEW	VERSION: 00	TDR: 000001072453
REV. LTR: -	REVISED: 08:46:49 06/19/2018	BY: ENBRISO
FILE: \AAA\00243\304		
MTL: -		

BALDOR - RELIANCE[®]
 HORZ TEFC 324-6TS (FARM DUTY)
 SH 1 of 1

CD0180



LOW VOLTAGE
(2D)



HIGH VOLTAGE
(1D)

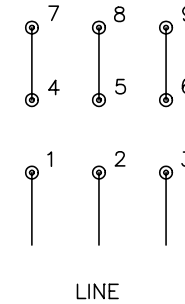

NOTES:

1. INTERCHANGE ANY TWO LINE LEADS TO REVERSE ROTATION.
2. OPTIONAL THERMOSTATS ARE PROVIDED WHEN SPECIFIED.
3. ACTUAL NUMBER OF INTERNAL PARALLEL CIRCUITS MAY BE A MULTIPLE OF THOSE SHOWN ABOVE.
4. LEAD COLORS ARE OPTIONAL. LEADS MUST ALWAYS BE NUMBERED AS SHOWN.

REV. DESC: REVISE TO SHOW OPTIONAL COLORS			
REV. LTR: C	BY: JLP	REVISED: 01/21/99 2:28	TDR: 0171435
0810D0		FILE: AAA00005148	MDL: -
		MTL: -	

BALDOR ELECTRIC Co.

3PH, DV, 9 LEADS, DELTA CONNECTION

CD0180

Marketing maintained PDF of MN416:

<http://www.baldor.com/support/Literature/Load.ashx/MN416?ManNumber=MN416>