

BALDOR® • RELIANCE 

Product Information Packet

FPM2562T-4

200/150HP,60//50HZ,2PL,3PH,444TS,OPEN

Part Detail							
Revision:	F	Status:	PRD/A	Change #:		Proprietary:	No
Type:	AC	Elec. Spec:	A44WG5441	CD Diagram:	421948-079	Mfg Plant:	
Mech. Spec:		Layout:	617428-044	Poles:	02	Created Date:	09-17-2015
Base:		Eff. Date:	02-01-2017	Leads:	12#6		

Specs			
Catalog Number:	FPM2562T-4	Duty Rating:	CONT
Enclosure:	DP	Feedback Device:	NO FEEDBACK
Frame:	444TS	Heater Indicator:	No Heater
Frame Material:	Iron	Insulation Class:	F
Output @ Frequency:	200.000 HP @ 60 HZ	Inverter Code:	Not Inverter
	150.000 HP @ 50 HZ	KVA Code:	E
Synchronous Speed @ Frequency:	3600 RPM @ 60 HZ	Lifting Lugs:	No Lifting Lugs
Voltage @ Frequency:	380.0 V @ 50 HZ	Motor Lead Quantity/Wire Size:	12 @ 6 AWG
	460.0 V @ 60 HZ	Motor Type:	A44048M
XP Class and Group:	None	Mounting Arrangement:	F1
XP Division:	Not Applicable	Power Factor:	85
Agency Approvals:	CCSA US	Product Family:	Other
	CSA EEV	Pulley End Bearing Type:	Ball
	UL	Pulley Face Code:	Standard
Auxillary Box:	No Auxillary Box	Shaft Ground Indicator:	No Shaft Grounding
Base Indicator:	Rigid	Shaft Rotation:	Reversible
Bearing Grease Type:	Polyrex EM (-20F +300F)	Shaft Slinger Indicator:	No Slinger
Current @ Voltage:	212.000 A @ 380.0 V	Speed Code:	Single Speed

	232.000 A @ 460.0 V	Motor Standards:	NEMA
Design Code:	B	Starting Method:	Wye Start - Delta Run
Drip Cover:	No Drip Cover	Thermal Device - Bearing:	None
		Thermal Device - Winding:	None

Nameplate NP3488L											
CAT.NO.	FPM2562T-4			CUST P/N				I.P.			
SPEC.	P44G1851			SER.NO.				FRAME	444TS		
HZ	60	HP	200	RPM	3560	HZ	50	HP	150	RPM	2965
VOLTS	460			CODE	E	VOLTS	380			CODE	F
AMPS	232			DES	B	AMPS	212			DES	B
EFF	94.5	SER.F.	1.15	PF	85	EFF	94.5	SER.F.	1.15	PF	87
RATING	40C AMB-CONT			DE BRG	65BC03J30X			GREASE	POLYREX EM		
BLANK				ODE BRG	65BC03J30X			MTR. WT.	1449		
				CLASS	F	PH	3				
				ENCL	DP	CC	010A				
HTR-VOLTS		HTR-AMPS		HTR-WATTS		MAX. SPACE HEATER TEMP.					

Parts List		
Part Number	Description	Quantity
SA312141	SA P44G1851	1.000 EA
RA299579	RA P44G1851	1.000 EA
000692000VD	LABEL WARNING	1.000 EA
NP3488L	ALUM FIRE PUMP MOTOR (ATHENS PLANT ONLY)	1.000 EA
421948079R	MYLAR DIAG 12 LEAD PWS OR WYE-DELTA	1.000 EA
004824015A	GREASE POLYREX EM	0.544 LB
032018028CK	HHCS 3/8-16X3-1/2 PLTD.	3.000 EA
032018028EK	HHCS 5/8-11X3-1/2L PLTD	4.000 EA
034000012AB	WSHR 1/4 STD. PLATED	4.000 EA
034017012AB	LCKW 1/4 STD. PLATED	4.000 EA
034600001AA	BUSH 1/4TO1/8 BLACK	1.000 EA
035000001G	GREASE RELIEF FITTING, ALEMITE 317400	1.000 EA
035000001G	GREASE RELIEF FITTING, ALEMITE 317400	1.000 EA
089438082A	BRKT 440 089438081WCB	1.000 EA
410700004F	WSHR	1.000 EA
702611001A	BAFFL 440 SUB PAINT	1.000 EA
032018028CK	HHCS 3/8-16X3-1/2 PLTD.	3.000 EA
032018028EK	HHCS 5/8-11X3-1/2L PLTD	4.000 EA
034000012AB	WSHR 1/4 STD. PLATED	4.000 EA
034017012AB	LCKW 1/4 STD. PLATED	4.000 EA
034600001AA	BUSH 1/4TO1/8 BLACK	1.000 EA
089438082A	BRKT 440 089438081WCB	1.000 EA
702611001A	BAFFL 440 SUB PAINT	1.000 EA
032018008DK	HHCS 1/2-13X1 PLATED	4.000 EA

Parts List (continued)		
Part Number	Description	Quantity
033512004LB	HHTTS 1/4-20X1/2 PLTD.	1.000 EA
033512006LB	HHTTS 1/4-20X3/4 PLTD.	8.000 EA
035000001A	ALFTG 1/8" 1610-BL	1.000 EA
035000001A	ALFTG 1/8" 1610-BL	1.000 EA
048897010DG	PLUG,ODE BRKT - 360	1.000 EA
415000103D	T/LUG #4AWG-1/0AWG W/HOLE FOR .250 BOLT	1.000 EA
418150003A	GREASE FITTING CAP	1.000 EA
418150003A	GREASE FITTING CAP	1.000 EA
702658001A	CONDUIT BOX, E440	1.000 EA
702658002A	+C/BOX CVR, PAINTED 440	1.000 EA
MG1025R44	WILKOFAS, 784.109, CARMINE RED #3002	0.250 GA
033775004EA	DRSCR #6-1/4 304 S.S.	2.000 EA
034180024HA	KEY 5/8X5/8X3 L	1.000 EA
405851012AJ	SPACE	4.000 EA
032018016AK	HHCS 1/4-20X2L PLTD.	4.000 EA
032018016AK	HHCS 1/4-20X2L PLTD.	4.000 EA
PK5004A09	BASE 48 X 39-1/4 STACK 2 X 4 RUUNER	1.000 EA
405851012AJ	SPACE	4.000 EA

REL. S.O.	FRAME	HP	TYPE	PHASE/HERTZ	RPM	VOLTS
	444TS	200	P	3/60	3560	460
AMPS	DUTY	AMB °C/ INSUL.	S.F.	NEMA DESIGN	CODE LETTER	ENCL.
232	CONT	40/B	1.15	B	E	ODP
E/S	ROTOR	TEST S.O.	TEST DATE	STATOR RES. @25 °C (OHMS (BETWEEN LINES))		
-	418143013PE	---	---	.0310		

PERFORMANCE

LOAD	HP	AMPERES	RPM	POWER FACTOR %	EFFICIENCY %
NO LOAD	0	74.2	3600	5.97	0
1/4	50.1	94.1	3591	54.9	90.7
2/4	100	131	3583	75.7	94.1
3/4	150	179	3573	82.8	94.8
4/4	200	232	3564	85.3	94.7
5/4	250	286	3553	86.7	94.3

SPEED TORQUE

	RPM	TORQUE % FULL LOAD	TORQUE LB.-FT.	AMPERES
LOCKED ROTOR	0	151	444	1245
PULL UP	1800	127	376	1088
BREAKDOWN	3426	234	690	721
FULL LOAD	3564	100	295	232

AMPERES SHOWN FOR 460. VOLT CONNECTION. IF OTHER VOLTAGE CONNECTIONS ARE AVAILABLE, THE AMPERES WILL VARY INVERSELY WITH THE RATED VOLTAGE

REMARKS: NEMA NOM. EFF. 94.5% - GUAR. MIN. EFF. 94.1 %
FIRE PUMP MOTOR



DR. BY CD
 CK. BY T. RELIANT
 APP. BY T. RELIANT
 DATE 09/23/2015

A-C MOTOR
 PERFORMANCE DATA
 A44WG5441-R001
 ISSUE DATE 09/23/20

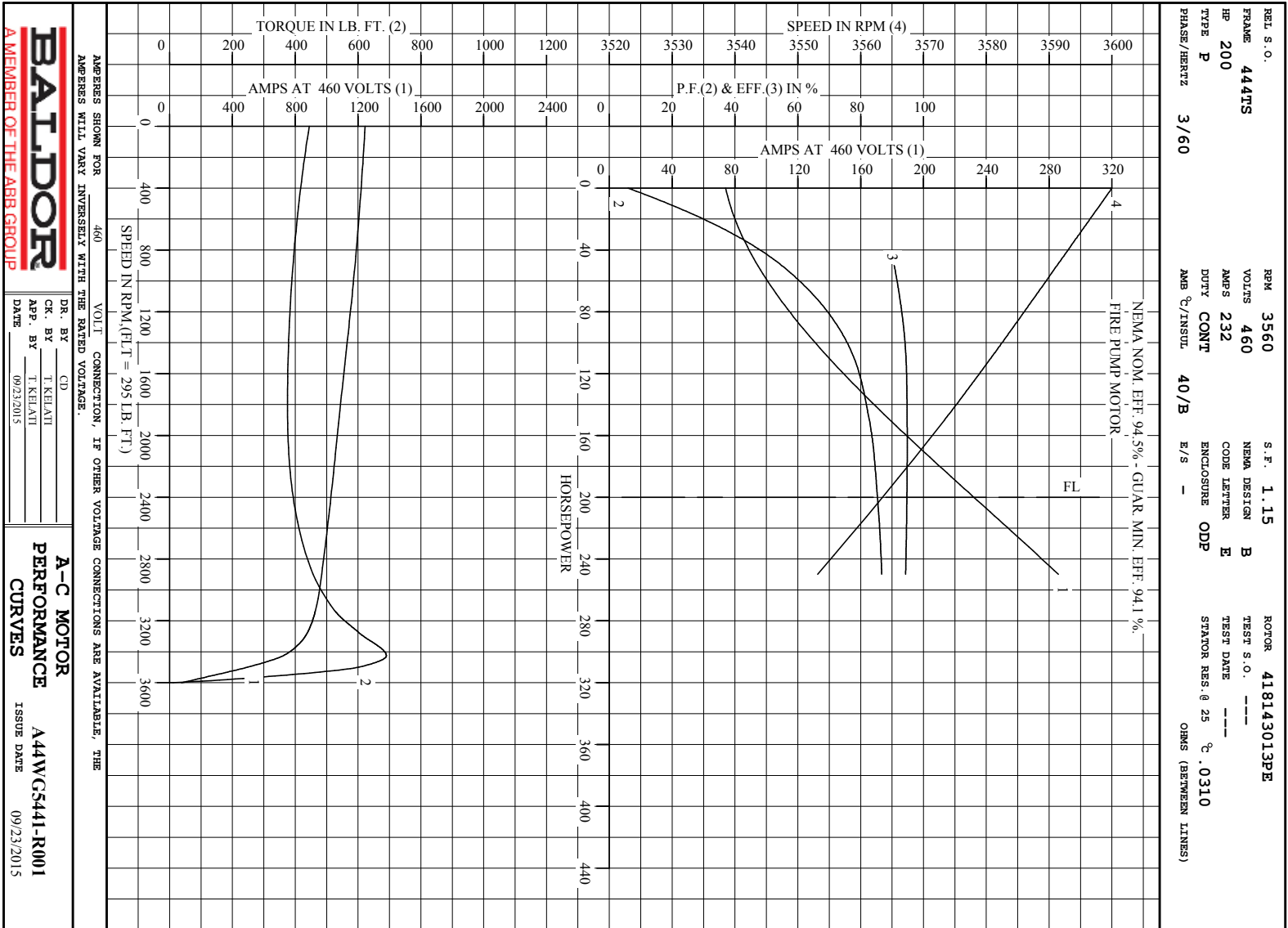

BALDOR
A MEMBER OF THE ABB GROUP

DR. BY CD
CK. BY T. KEHATI
APP. BY T. KEHATI
DATE 09/23/2015

A-C MOTOR
PERFORMANCE
CURVES
A44WC5441-R001
ISSUE DATE 09/23/2015

Printed on 12/17/15 14:12 @ bengap01.baldor.com

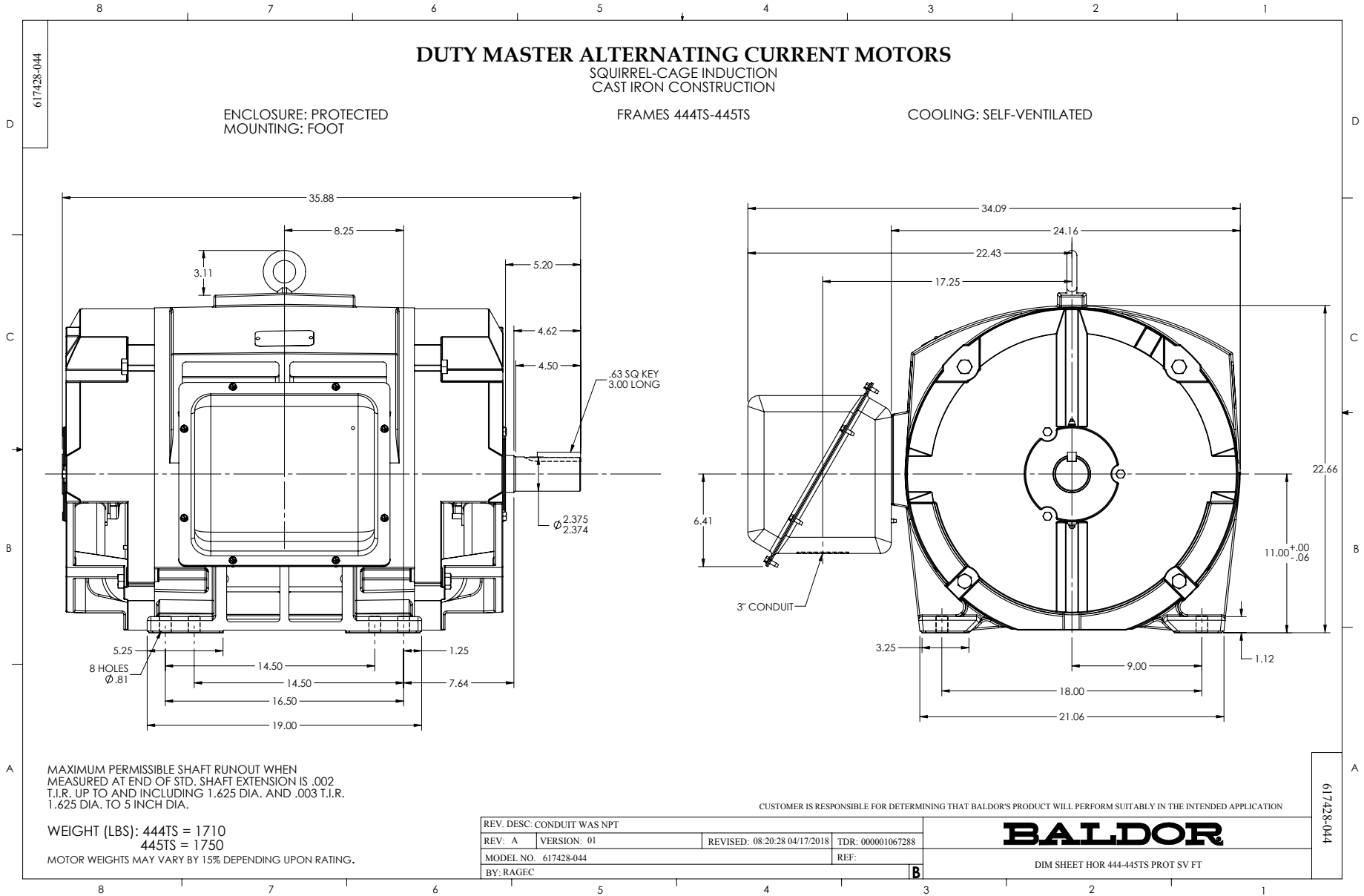

421948-079

TOLERANCE UNLESS OTHERWISE SHOWN
 ONE PLACE DECIMAL ±.1
 TWO PLACE DECIMAL ±.02
 THREE PLACE DECIMAL ±.003
 ANGLE ±0°-30'

SURFACE FINISH $\sqrt{250}$

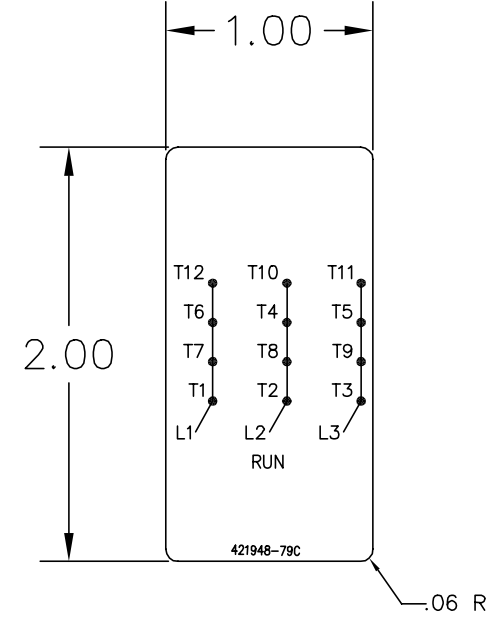
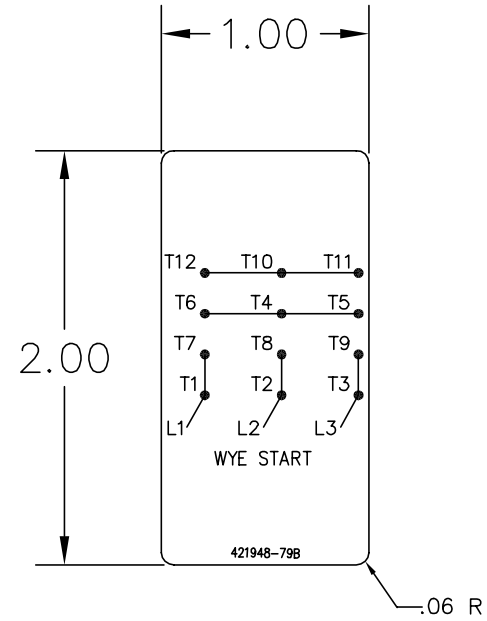
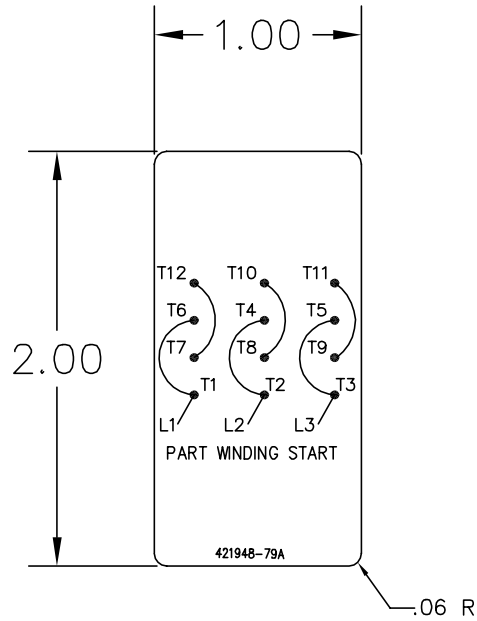

MATERIAL SPECIFICATION: .005 THICK DULL SILVER MYLAR,
 TOPCOAT-ARMORCOTE, PS ADHESIVE, LABEL MUST MEET THE
 REQUIREMENTS AS SPECIFIED IN CANADIAN STANDARDS
 ASSOCIATION: "CSA TESTING LABORATORIES TEST PROGRAM
 FOR ADHESIVE TYPE NAMEPLATES".
 LETTERING: UNIVERSAL TYPE UNLESS OTHERWISE SPECIFIED.
 COLORS: 1) BLACK ON NATURAL BACKGROUND

REF: 410961-66A

-	1	421948-79C	RUN CONNECTION
-	1	421948-79B	WYE START
-	1	421948-79A	PART WINDING START
-	R	PART	DESCRIPTION

421948-079

REV. DESC:			
REV. LTR: A	VERSION: 01	TDR: 000000591489	
FILE: \RAG\00013\521		REVISED: 01:12:47 04/18/2011	
MTL: -		BY: RAGBRP	

BALDOR

MYLAR 12 LEAD PWS OR WYE-DELTA WIRING DIAGRAM

SH 1 of 1

Marketing maintained PDF of MN408:

<http://www.baldor.com/support/Literature/Load.ashx/MN408?ManNumber=MN408>

Marketing maintained PDF of MN416:

<http://www.baldor.com/support/Literature/Load.ashx/MN416?ManNumber=MN416>